

Introduction to Basic Concepts in Immunology

GOVERNMENT DEGREE COLLEGE



6th SEMESTER

ZOO616DA: ZOOLOGY – IMMUNOLOGY

Unit 1st

1.1 introduction to basic concepts in immunology

Immunology is the science that is concerned with immune response to foreign challenges. Immunity (derived from Latin term *immunis*, meaning exempt), is the ability of an organism to resist infections by pathogens or state of protection against foreign organisms or substances. The array of cells, tissues and organs which carry out this activity constitute the immune system.

The immune system is remarkably versatile defence system that has evolved to protect animals from invading pathogenic microorganisms and cancer. It is able to generate an enormous variety of cells and molecules capable of specifically recognizing and eliminating an apparently limitless variety of foreign invaders. These cells and molecules act together in a dynamic network whose complexity rivals that of the nervous system. Functionally, an immune response can be divided into two related activities—recognition and response. Immune recognition is remarkable for its specificity. The immune system is able to recognize subtle chemical differences that distinguish one foreign pathogen from another. Furthermore, the system is able to discriminate between foreign molecules and the body's own cells and proteins. Once a foreign organism has been recognized, the immune system recruits a variety of cells and molecules to mount an appropriate response, called an effector response, to eliminate or neutralize the organism. In this way the system is able to convert the initial recognition event into a variety of effector responses, each uniquely suited for eliminating a particular type of pathogen. Later exposure to the same foreign organism induces a memory response, characterized by a more rapid and heightened immune reaction that serves to eliminate the pathogen and prevent disease.

Thucydides wrote in his History of the Peloponnesian War that persons who had been exposed to plague previously could care for the sick without danger. In the 19th century, variolation was commonplace; this was the removal of smallpox (*variola virus*) skin pustules which were subsequently put into small cuts in the skin of healthy people. This was itself a crude form of vaccination, with the crusty dry pustules acting as an incubator of attenuated virus. Edward Jenner would later use the cowpox virus to vaccinate (from *vacca*, Latin for "cow") patients against smallpox, and Louis Pasteur attenuated rabies and injected it into a small boy, naming this substance a vaccine in honor of Jenner's earlier studies in the science of immunology.

As immunology progressed, many people began to question how these vaccines worked. Why should exposure to plague in Thucydides' time confer protection only against plague and not all disease? Why should cowpox, a similar disease to smallpox but clearly a less severe virus, give milk maids sufficient immunity to resist full smallpox infection? In short, what has caused this memory response to be relatively (yet not absolutely) specific as well as selective

Basics

- Serum--liquid, noncellular component of blood after coagulation has occurred (and thus devoid of clotting factors).
- Immunoglobulin--a serum fraction (aka gamma globulin) that has antitoxin, precipitin, and agglutin factors (abbreviation: Ig)

- Antigen--"**Antibody Generator**"; a foreign organism or molecule that generates a humoral immune response, causing the release of antibodies (abbreviation: Ag)
- Epitope--the molecular sidechain of an antigen that each antibody attaches to; there can be many epitopes on a single antigen
- Antibody--refined, Y-shaped proteins that make up the immunoglobulin fraction of serum; antibodies are specific to certain foreign bodies; antibodies can be membrane-bound or free in the serum (abbreviation: Ab)

Note: Often, antibody and immunoglobulin are used interchangeably. antigen and immunogen are used interchangeably (but to be precise, they are not the same)

Immunity is typically divided into two categories—innate and adaptive immunity

Innate and Adaptive Immunity

The immune system protects organisms from infection with layered defenses of increasing specificity. Physical barriers prevent pathogens, such as bacteria and viruses, from entering the organism. If a pathogen breaches these barriers, the innate immune system provides an immediate, but non-specific response. Innate immune systems are found in all plants and animals. If pathogens successfully evade the innate response, vertebrates possess a second layer of protection, the adaptive immune system, which is activated by the innate response. The immune system adapts its response during an infection in order to improve its recognition of the pathogen. This improved response is then retained after the pathogen has been eliminated, in the form of an immunological memory, and allows the adaptive immune system to mount faster and stronger attacks when this pathogen is encountered. Both innate and adaptive immunity depend on the ability of the immune system to distinguish between self and non- self molecules, where self molecules are those components of an organism's body that can be distinguished from foreign substances by the immune system.

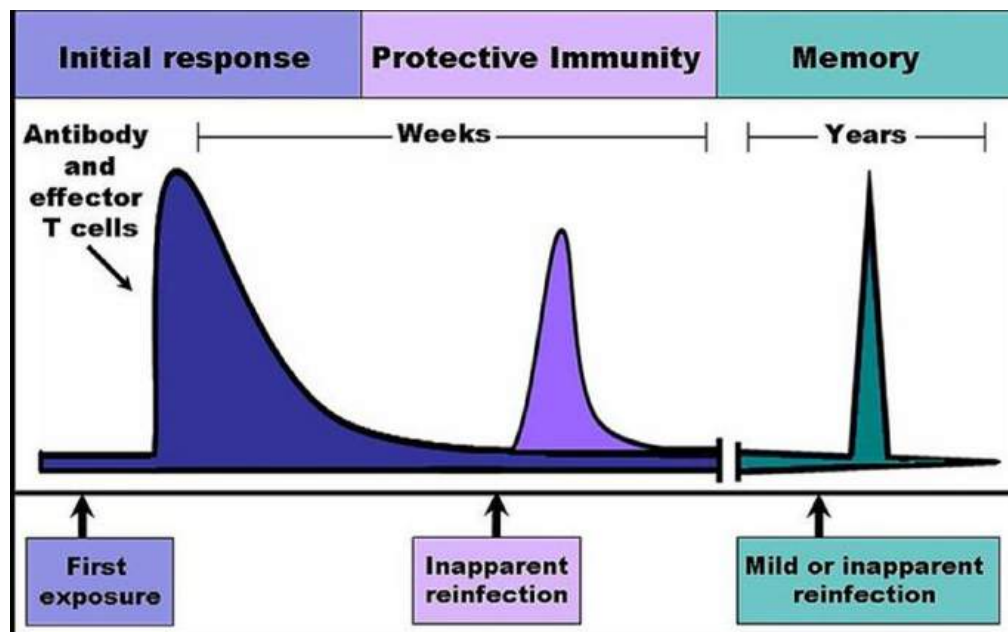

The Time Course of an Immune Response: Immune reactants, such as antibodies and effector T-cells, work to eliminate an infection, and their levels and activity rapidly increase following an

encounter with an infectious agent, whether that agent is a pathogen or a vaccine. For several weeks these reactants remain in the serum and lymphatic tissues and provide protective immunity against reinfection by the same agent. During an early reinfection, few outward symptoms of illness are present, but the levels of immune reactants increase and are detectable in the blood and/or lymph. Following clearance of the infection, antibody level and effector T cell activity gradually declines. Because immunological memory has developed, reinfection at later times leads to a rapid increase in antibody production and effector T cell activity. These later infections can be mild or even inapparent.

Immunity is a biological term that describes a state of having sufficient biological defences to avoid infection, disease, or other unwanted biological invasion. Immunity involves both specific and non-specific components.

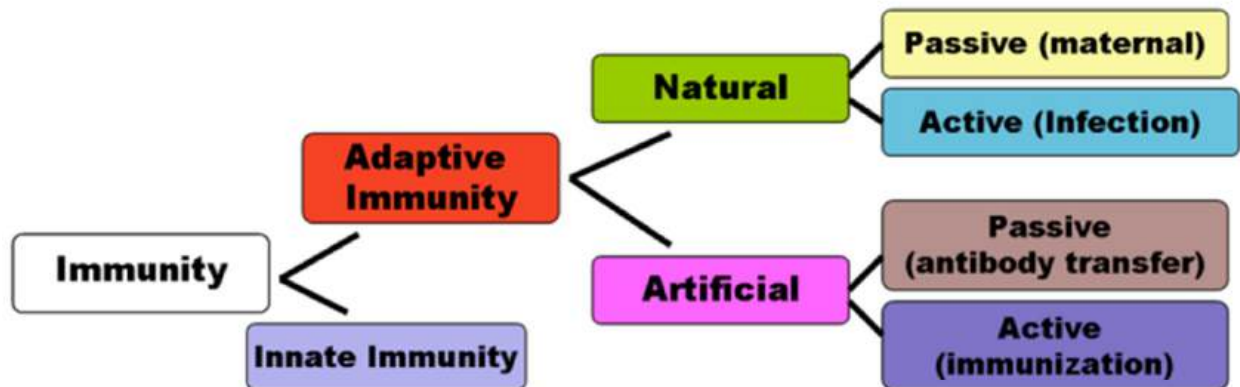

Immunity: Natural immunity occurs through contact with a disease causing agent, when the contact was not deliberate, whereas artificial immunity develops only through deliberate actions of exposure. Both natural and artificial immunity can be further subdivided, depending on the amount of time the protection lasts. Passive immunity is short lived, and usually lasts only a few months, whereas protection via active immunity lasts much longer, and is sometimes life-long.

INNATE IMMUNITY

Innate, or nonspecific, immunity is the natural resistance with which a person is born. It provides resistance through several physical, chemical, and cellular approaches. Microbes first encounter the epithelial layers (physical barriers that line our skin and mucous membranes). Subsequent general defenses include secreted chemical signals (cytokines), antimicrobial substances, fever, and phagocytic activity associated with the inflammatory response. The phagocytes express cell surface receptors that can bind and respond to common molecular patterns expressed on the surface of invading microbes. Through these approaches, innate immunity can prevent the colonization, entry, and spread of microbes.

ADAPTIVE IMMUNITY

Adaptive immunity is often sub-divided into two major types depending on how the immunity was introduced. Naturally acquired immunity occurs through contact with a disease causing agent, when the contact was not deliberate, whereas artificially acquired immunity develops only through deliberate actions such as vaccination. Both naturally and artificially acquired immunity can be further subdivided depending on whether immunity is induced in the host or passively transferred

from an immune host. Passive immunity is acquired through transfer of antibodies or activated T cells from an immune host, and is short lived—usually lasting only a few months. Active immunity is induced in the host itself by antigen, and lasts much longer, sometimes the entire lifetime.

A further subdivision of adaptive immunity is characterized by the cells involved; humoral immunity is the aspect of immunity that is mediated by secreted antibodies, whereas the protection provided by cell-mediated immunity involves T lymphocytes alone. Humoral immunity is active when the organism generates its own antibodies, and passive when antibodies are transferred between individuals. Similarly, cell-mediated immunity is active when the organism's own T cells are stimulated and passive when T cells come from another organism.

1.2 Componentets of the immune system

The immune system includes primary lymphoid organs, secondary lymphatic tissues and various cells in the innate and adaptive immune systems.

Immune System Organs

The key primary lymphoid organs of the immune system include the thymus and bone marrow, as well as secondary lymphatic tissues including spleen, tonsils, lymph vessels, lymph nodes, adenoids, skin, and liver.

The thymus “educates” T cells and provides an inductive environment for the development of T cells from hematopoietic progenitor cells. The thymus is largest and most active during the neonatal and pre-adolescent periods of development. By the early teens, the thymus begins to atrophy and thymic stroma is replaced by adipose tissue. Nevertheless, residual T-lymphopoiesis continues throughout adult life.

Bone marrow is the flexible tissue found in the interior of bones. In humans, red blood cells are produced in the heads of long bones. The red bone marrow is a key element of the lymphatic system, being one of the primary lymphoid organs that generate lymphocytes from immature hematopoietic progenitor cells. Bone marrow and thymus constitute the primary lymphoid tissues involved in the production and early selection of lymphocytes.

The lymphatic system is a part of the circulatory system, comprising a network of conduits called lymphatic vessels that carry a clear fluid, called lymph, unidirectionally towards the heart. The lymphatic system has multiple interrelated functions including the transportation of white blood cells to and from the lymph nodes into the bones, and the transportation of antigen -presenting cells (such as dendritic cells) to the lymph nodes where an immune response is stimulated. Lymphoid tissue is found in many organs, particularly the lymph nodes.

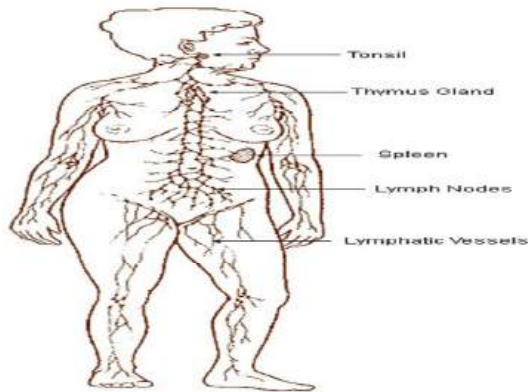

The lymphatic system is a part of the circulatory system, comprising a network of conduits called lymphatic vessels that carry a clear fluid called lymph.

The spleen is similar in structure to a large lymph node and acts primarily as a blood filter. It synthesizes antibodies in its white pulp and removes antibody-coated bacteria along with antibody-coated blood cells by way of blood and lymph node circulation.

The palatine tonsils and the nasopharyngeal tonsil are lymphoepithelial tissues located near the oropharynx and nasopharynx. These immunocompetent tissues are the immune system's first line of defense against ingested or inhaled foreign pathogens. The fundamental immunological roles of tonsils aren't yet understood.

Lymph nodes are distributed widely throughout areas of the body, including the armpit and stomach, and linked by lymphatic vessels. Lymph nodes are garrisons of B, T and other immune cells. Lymph nodes act as filters or traps for foreign particles and are important in the proper functioning of the immune system. They are packed tightly with the white blood cells, called lymphocytes and macrophages.

The skin is one of the most important parts of the body because it interfaces with the environment, and is the first line of defense from external factors, acting as an anatomical barrier from pathogens and damage between the internal and external environment in bodily defense. Langerhans cells in the skin are part of the adaptive immune system.

The liver has a wide range of functions, including immunological effects—the reticuloendothelial system of the liver contains many immunologically active cells, acting as a "sieve" for antigens carried to it via the portal system.

Immune System Cells

Leukocytes (white blood cells) are immune system cells involved in defending the body against infectious disease and foreign materials. Five different types of leukocytes exist, all produced and derived from a multipotent cell in the bone marrow known as a hematopoietic stem cell. The innate leukocytes include the phagocytes, mast cells, eosinophils, basophils, and natural killer cells. These cells identify and eliminate pathogens and are important mediators in the activation of the adaptive immune system.

Neutrophils and macrophages are phagocytes that travel throughout the body in pursuit of invading pathogens. Neutrophils are normally found in the bloodstream and are the most abundant type of phagocyte. During the acute phase of inflammation neutrophils migrate toward the site of inflammation and are usually the first cells to arrive at the scene of infection. Macrophages reside

within tissues and produce a wide array of chemicals. They also act as scavengers, ridding the body of worn-out cells and other debris, and as antigen-presenting cells that activate the adaptive immune system. Dendritic cells are phagocytes in tissues that are in contact with the external environment, and are located mainly in the skin, nose, lungs, stomach, and intestines. These cells serve as a link between the bodily tissues and the innate and adaptive immune systems, as they present antigen to T-cells, one of the key cell types of the adaptive immune system.

Mast cells reside in connective tissues and mucous membranes, and regulate the inflammatory response. They are most often associated with allergy and anaphylaxis.

Basophils and eosinophils are related to neutrophils. They secrete chemical mediators that are involved in defending against parasites, and play a role in allergic reactions, such as asthma.

Natural killer cells are leukocytes that attack and destroy tumor cells, or cells that have been infected by viruses.

The cells of the adaptive immune system are special types of leukocytes, called lymphocytes. B cells and T cells are the major types of lymphocytes and are derived from hematopoietic stem cells in the bone marrow.

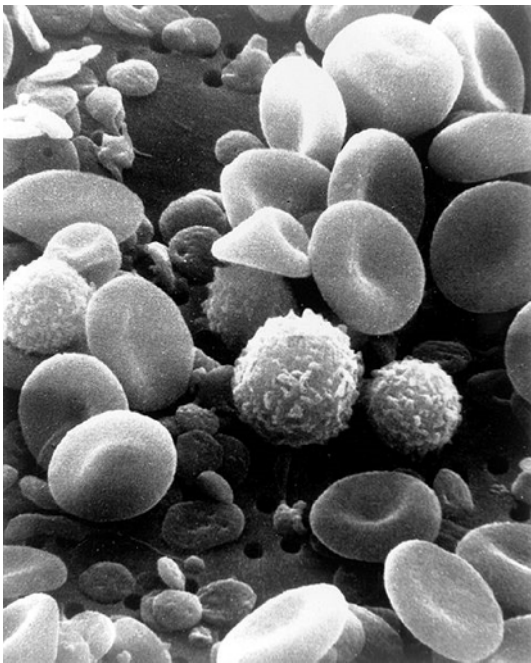

Blood Cells: Red blood cells, several white blood cells including lymphocytes, a monocyte, a neutrophil, and many small disc-shaped platelets.

T cells recognize a “non-self” target, such as a pathogen, only after antigens have been processed and presented in combination with a “self” receptor, called a major histocompatibility complex (MHC) molecule. There are two major subtypes of T cells: the killer T cell, which kills cells that are infected with viruses (and other pathogens) or are otherwise damaged or dysfunctional, and the helper T cell, which regulates both innate and adaptive immune responses and helps determine which immune responses the body makes to a particular pathogen. These cells have no cytotoxic activity and do not kill infected cells or clear pathogens directly. A third, minor subtype are the γ T cells that recognize intact antigens not bound to MHC receptors.

In contrast, the B cell antigen-specific receptor is an antibody molecule on the B cell surface, which recognizes whole pathogens without any need for antigen processing. Each lineage of B cell expresses a different antibody, so the complete set of B cell antigen receptors represent all the antibodies that the body can manufacture.

1.3 Principles of innate and adaptive immunity, Haematopoiesis

(A) Innate or Natural or Nonspecific Immunity (L. innatus = inborn):

Innate (native/natural) immunity is present since birth and consists of many factors that are relatively nonspecific— that is, it operates against almost any foreign molecules and pathogens. It provides the first line of defense against pathogens. It is not specific to any one pathogen but rather acts against all foreign molecules and pathogens. It also does not rely on previous exposure to a pathogen and response is functional since birth and has no memory.

Innate immunity consists of four types of barriers— physical, physiological, cellular and cytokine barriers.

1. Physical Barriers:

They are mechanical barriers to many microbial pathogens. These are of two types. Skin and mucous membrane.

(a) Skin:

The skin is physical barrier of body. Its outer tough layer, the stratum corneum prevents the entry of bacteria and viruses.

(b) Mucous Membranes:

Mucus secreted by mucous membrane traps the microorganisms and immobilises them. Microorganisms and dust particles can enter the respiratory tract with air during breathing which are trapped in the mucus. The cilia sweep the mucus loaded with microorganisms and dust particles into the pharynx (throat). From the pharynx it is thrown out or swallowed for elimination with the faeces.

2. Physiological Barriers:

The skin and mucous membranes secrete certain chemicals which dispose off the pathogens from the body. Body temperature, pH of the body fluids and various body secretions prevent growth of many disease causing microorganisms. Some of the important examples of physiological barriers are as follows:

(a) Acid of the stomach kills most ingested microorganisms,

(b) Bile does not allow growth of microorganisms,

- (c) Cerumen (ear wax) traps dust particles, kills bacteria and repels insects,
- (d) Lysozyme is present in tissue fluids and in almost all secretions except in cerebrospinal fluid, sweat and urine. Lysozyme is in good quantity in tears from eyes. Lysozyme attacks bacteria and dissolves their cell walls. Lysoenzyme is also found in saliva,
- (e) Nasal Hair. They filter out microbes and dust in nose,
- (f) Urine. It washes microbes from urethra,
- (g) Vaginal Secretions. It is slightly acidic which discourages bacterial growth and flush microbes out of vagina,
- (h) Sebum (sweat). It forms a protective acid film over the skin surface that inhibits growth of many microbes.

3. Cellular Barriers:

These are certain white blood corpuscles (leucocytes), macrophages, natural killer cells, complement system, inflammation, fever, antimicrobial substances, etc.

(i) Certain Leucocytes:

Neutrophils and monocytes are major phagocytic leucocytes.

(a) Polymorpho-nuclear Leucocytes (PMNL- neutrophils):

As they have multilobed nucleus they are normally called polymorphonuclear leucocytes (PMNL-neu- trophils). Neutrophils are short lived and are highly motile phagocytic killers. Neutrophils are formed from stem cells in the bone marrow. Neutrophils are the most numerous of all leucocytes. They die after a few days and must therefore, be constantly replaced. Neutrophils constitute about 40% to 75% of the blood leucocytes in humans.

(b) Monocytes:

They are the largest of all types of leucocytes and somewhat amoeboid in shape. They have clear cytoplasm (without cytoplasmic granules). The nucleus is bean-shaped. Monocytes constitute about 2-10% of the blood leucocytes. They are motile and phagocytic in nature and engulf bacteria and cellular debris. Their life span is about 10 to 20 hours. Generally they change into macrophages after entering tissue spaces.

(ii) Macrophages:

Monocytes circulate in the bloodstream for about 8 hours, during which time they enlarge and then migrate into the tissues and differentiate into specific tissue macrophages. Macrophages are long lived and are highly motile phagocytic.

Macrophages contain more cell organelles especially lysosomes. Macrophages are of two types, (a) Some take up residence in particular tissues becoming fixed macrophages and (b) whereas other remain motile and are called wandering macrophages. Wandering macrophages move by amoeboid movement throughout the tissues. Fixed macrophages serve different functions in different tissues and are named to reflect their tissue location. Some examples are given below:

- i. Pulmonary alveolar macrophages in the lung
- ii. Histiocytes in connective tissues

- iii. Kupffer cells in the liver
- iv. Glomerular Mesangial cells in the kidney
- v. Microglial cells in the brain
- vi. Osteoclasts in bone

(iii) Natural Killer Cells (NK Cells):

Besides the phagocytes, there are natural killer cells in the body which are a type of lymphocytes and are present in the spleen, lymph nodes and red bone marrow. NK cells do not have antigen receptors like T cells and B cells. NK cells cause cellular destruction in at least two ways:

(a) NK cells produce perforins which are chemicals that when inserted into the plasma membrane of a microbe make so weak that cytolysis (breakdown of cells particularly their outer membrane) occurs and creates pores in the plasma membrane of the target cells. These pores allow entry of water into the target cells, which then swell and burst. Cellular remains are eaten by phagocytes.

(b) Another function of NK cells is apoptosis which means natural cell death. It occurs naturally as part of the normal development, maintenance and renewal of cells, tissues and organs.

Thus functions of NK cells are to destroy target cells by cytolysis and apoptosis. NK cells constitute 5%-10% of the peripheral blood lymphocytes in humans.

(iv) Complement (Fig. 8.7):

Complement is a group of 20 proteins, many of which are enzyme precursors and are produced by the liver. These proteins are present in the serum of the blood (the fluid portion of the blood excluding cells and clotting factors) and on plasma membranes. They are found circulating in the blood plasma and within tissues throughout the body. They were named complement by Ehrlich because they complement the actions of other components of the immune system (e.g., action of antibody on antigen) in the fight against infection. Jules Bordet is the discoverer of complement.

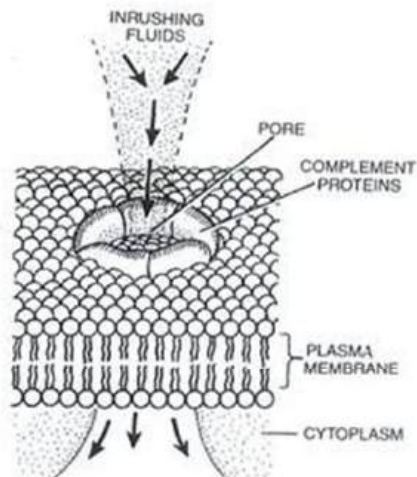

Fig. 8.7. Complement proteins creating a hole in the plasma membrane.

Complement proteins create pores in the plasma membrane of the microbes. Water enters the microbes. The latter burst and die. The proteins of complement system destroy microbes by (i)

cytolysis (ii) inflammation and (iii) phagocytosis. These proteins also prevent excessive damage of the host tissues.

(v) Inflammation:

Inflammation is a defensive response of the body to tissue damage. The conditions that may produce inflammation are pathogens, abrasions (scraping off) chemical irritations, distortion or disturbances of cells, and extreme temperatures. The signs and symptoms of inflammation are redness, pain, heat and swelling.

Inflammation can also cause the loss of function in the injured area, depending on the site and extent of the injury. Inflammation is an attempt to dispose of microbes, toxins, or foreign material at the site of injury to prevent their spread to other tissues, and to prepare the site for tissue repair. Thus, it helps restore tissue homeostasis.

Broken mast cells release histamine. Histamine causes dilation of capillaries and small blood vessels. As a result more blood flows to that area making it red and warm and fluid (plasma) takes out into the tissue spaces causing its swelling. This reaction of the body is called inflammatory response.

(vi) Fever:

Fever may be brought about by toxins produced by pathogens and a protein called endogenous pyrogen (fever producing substance), released by macrophages. When enough pyrogens reach the brain, the body's thermostat is reset to a higher temperature, allowing the temperature of the entire body to rise.

Mild fever strengthens the defence mechanism by activating the phagocytes and by inhibiting the growth of microbes. A very high temperature may prove dangerous. It must be quickly brought down by giving antipyretics.

4. Cytokine Barriers:

Cytokines (Chemical messengers of immune cells) are low molecular weight proteins that stimulate or inhibit the differentiation, proliferation or function of immune cells. They are involved in the cell to cell communication. Kinds of cytokines include interleukins produced by leucocytes, lymphocytes produced by lymphocytes, tumour necrosis factor and interferon's (IFNs). Interferon's protect against viral infection of cells.

(B) Acquired Immunity (= Adaptive or Specific Immunity):

The immunity that an individual acquires after the birth is called acquired or adaptive or specific immunity. It is specific and mediated by antibodies or lymphocytes or both which make the antigen harmless.

It not only relieves the victim of the infectious disease but also prevents its further attack in future. The memory cells formed by B cells and T cells are the basis of acquired immunity. Thus acquired immunity consists of specialized B and T lymphocytes and Antibodies.

Characteristics of Acquired Immunity:

(i) Specificity:

It is the ability to differentiate between various foreign molecules (foreign antigens).

(ii) Diversity:

It can recognise a vast variety of foreign molecules (foreign antigens).

(iii) Discrimination between Self and Non-self:

It can recognise and respond to foreign molecules (non-self) and can avoid response to those molecules that are present within the body (self) of the animal.

(iv) Memory:

When the immune system encounters a specific foreign agent, (e.g., a microbe) for the first time, it generates immune response and eliminates the invader. This is called first encounter. The immune system retains the memory of the first encounter. As a result, a second encounter occurs more quickly and abundantly than the first encounter.

The cells of the immune system are derived from the pluripotent stem cells in the bone marrow. Pluripotent means a cell that can differentiate into many different types of tissue cells. The pluripotent stem cells can form either myeloid stem cells or lymphoid stem cells.

Myeloid stem cells give rise to monocytes, macrophages and granulocytes (neutrophils eosinophil's, and basophils). RBCs and blood platelets (lymphoid stem cells) form B lymphocytes (B cells), T lymphocytes (T-cells) and natural killer (NK) cells.

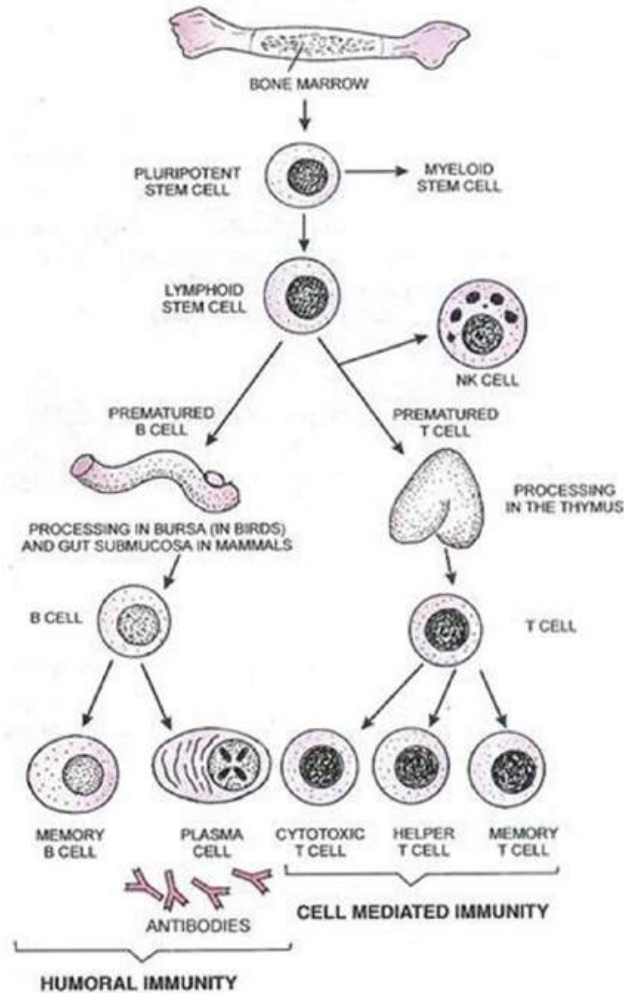

Development of B and T lymphocytes. Both arise from bone marrow precursors. Natural killer (NK) cells are a third population of lymphocytes that are distinct from T cells and B cells.

Components of Acquired Immunity:

Acquired immunity has two components: humoral immunity or Antibody mediated immune system (AMIS) and cellular immunity or cell mediated immune system (CMIS).

I. Antibody Mediated Immune System (AMIS) or Humoral Immunity:

It consists of antibodies (specialised proteins produced in the body in response to antigen) that circulate in the body fluids like blood plasma and lymph. The word 'humor' pertains to fluid. B lymphocytes (B cells) produce antibodies that regulate humoral immunity. The T-lymphocytes themselves do not secrete anti-bodies but help B lymphocytes produce them.

Certain cells of the bone marrow produce B lymphocytes and mature there. Since B lymphocytes produce antibodies, therefore, this immunity is called antibody mediated or humoral immunity. Humoral immunity or antibody-mediated immune system (AMIS) provides defence against most extracellular bacterial pathogens and viruses that infect through the respiratory and intestinal tract.

Formation of Plasma B cells and Memory B cells:

When antibodies on B cell's surface bind antigens (any substances that cause antibodies formation) the B cell is activated and divides, producing a clone (descendants of a single cell) of daughter B cells. These clones give rise to plasma B cells and memory B cells. This phenomenon is called clonal selection.

(a) Plasma B Cells (Effector B cells):

Some of the activated B cells enlarge, divide and differentiate into a clone of plasma cells. Although plasma cells live for only a few days, they secrete enormous amounts of antibody during this period.

(b) Memory B Cells:

Some activated B cells do not differentiate into plasma cells but rather remain as memory cells (Primed cells). They have a longer life span. The memory cells remain dormant until activated once again by a new quantity of the same antigen.

Role of AMIS:

The AMIS protects the body from (i) viruses (ii) some bacteria and (iii) toxins that enter the body fluids like blood and lymph.

II. Cell-Mediated Immune System (CMIS) or T-Cell Immunity:

A healthy person has about a trillion lymphocytes. Lymphocytes are of two types: T lymphocytes or T cells and B lymphocytes or B cells. As we know both types of lymphocytes and other cells of the immune system are produced in the bone marrow. The process of production of cells of immune system in the bone marrow is called haematopoiesis.

Because T lymphocytes (T cells) mature in the thymus, this immunity is also called T- cell immunity.

The T-cells play two important functions—effector and regulatory.

The effector function includes cytolysis (destruction of cells by immune processes) of cells infected with microbes and tumour cells and lymphokine production. The regulatory functions are either to increase or to suppress other lymphocytes and accessory cells.

Types of T-cells and their Functions:

1. Helper T cells (T_H):

T_H cells are most numerous of the T cells. They help in the functions of immune system. They produce a growth factor that stimulates B-cell proliferation and differentiation and also stimulates antibody production by plasma cells; enhance activity of cytotoxic T cells.

2. Cytotoxic T cells (T_c) or Killer cells:

These cells are capable of killing microorganisms and even some of the body's own cells directly hence they are called killer cells. The antigen receptors on the surfaces of the cytotoxic cells cause specific binding with antigens present on the surface of foreign cell.

Cell after binding, the cytotoxic T cell secretes hole-forming proteins, called perforins, that punch large round holes in the membrane of the foreign cell. Then fluid flows quickly into the cell from the interstitial space. In addition, the cytotoxic T cell releases cytotoxic substances directly into the

foreign cell. Almost immediately, the foreign cell becomes greatly swollen and it usually dissolves shortly thereafter.

Thus they destroy body cells infected by viruses and attack and kill bacteria, fungi, parasites and cancer cells.

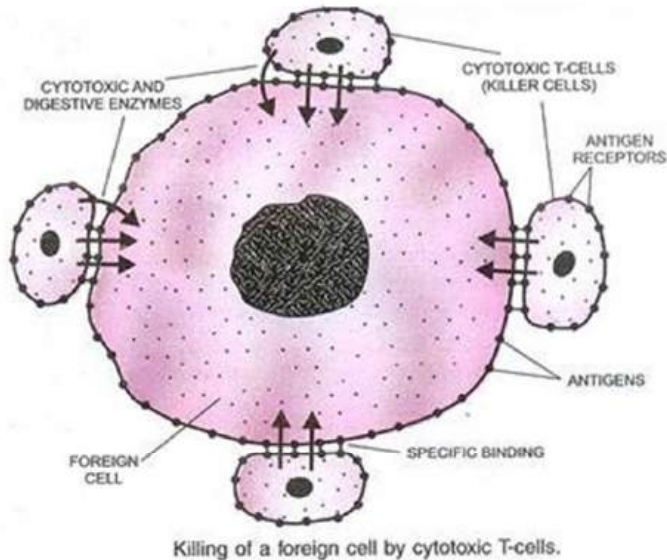

3. Memory T Cells (Primed Cells):

These cells are also formed by T-lymphocytes as a result of exposure to antigen and remain in the lymphatic tissue (e.g., spleen, lymph nodes). They recognize original invading antigens even years after the first encounter.

These cells keep ready to attack as soon as the same pathogens infect the body again. They proliferate and differentiate into cytotoxic T cells, helper T cells, suppressor T cells, and additional memory cells.

4. Suppressor Cells (Regulatory T cells (T_R)):

These cells are capable of suppressing the functions of cytotoxic and helper T cells. They also inhibit the immune system from attacking the body's own cells. It is believed that suppressor cells regulate the activities of the other cells. For this reason, the suppressor cells are classified as regulatory T cells.

Natural Killer (NK) Cells:

NK cells attack and destroy target cells, participate in antibody dependent cell mediated cytotoxicity. They can also attack parasites which are much larger than bacteria.

Types of Acquired Immunity:

Acquired (= Adaptive) Immunity is of two types: active immunity and passive immunity.

1. Active Immunity:

In this immunity person's own cells produce antibodies in response to infection or vaccination. It is slow and takes time in the formation of antibodies. It is long lasting and is harmless. Active immunity may be natural or artificial.

(a) A person who has recovered from an attack of small pox or measles or mumps develops natural active immunity.

(b) Artificial active immunity is the resistance induced by vaccines. Examples of vaccines are as follows: Bacterial vaccines, (a) Live- BCG vaccine for tuberculosis, (b) Killed vaccines- TAB vaccine for enteric fever. Viral vaccines, (a) Live – sabin vaccine for poliomyelitis, MMR vaccine for measles, mumps, rubella, (b) Killed vaccines- salk vaccine for poliomyelitis, neural and non-neural vaccines for rabies. Bacterial products. Toxoids for Diphtheria and Tetanus.

2. Passive Immunity:

When ready-made antibodies are directly injected into a person to protect the body against foreign agents, it is called passive immunity. It provides immediate relief. It is not long lasting. It may create problems. Passive immunity may be natural or artificial.

(a) Natural passive immunity is the resistance passively transferred from the mother to the foetus through placenta. IgG antibodies can cross placental barrier to reach the foetus. After birth, immunoglobulin's are passed to the new-born through the breast milk. Human colostrum (mother's first milk) is rich in IgA antibodies. Mother's milk contains antibodies which protect the infant properly by the age of three months.

(b) Artificial passive immunity is the resistance passively transferred to a recipient by administration of antibodies. This is done by administration of hyper-immune sera of man or animals. Serum (pi. sera) contains antibodies. For example, anti-tetanus serum (ATS) is prepared in horses by active immunisation of horses with tetanus toxoid, bleeding them and separating the serum. ATS is used for passive immunisation against tetanus. Similarly anti-diphtheric serum (ADS) and anti-gas gangrene serum (AGS) are also prepared.

Immune

Response:

The immune response involves primary immune response and secondary immune response.

(a) The primary immune response:

After an initial contact with an antigen, no antibodies are present for a period of several days. Then, a slow rise in the antibody titer o(arbitrary units) occurs, first IgM and then IgG followed by a gradual decline in antibody titer. This is called the primary immune response.

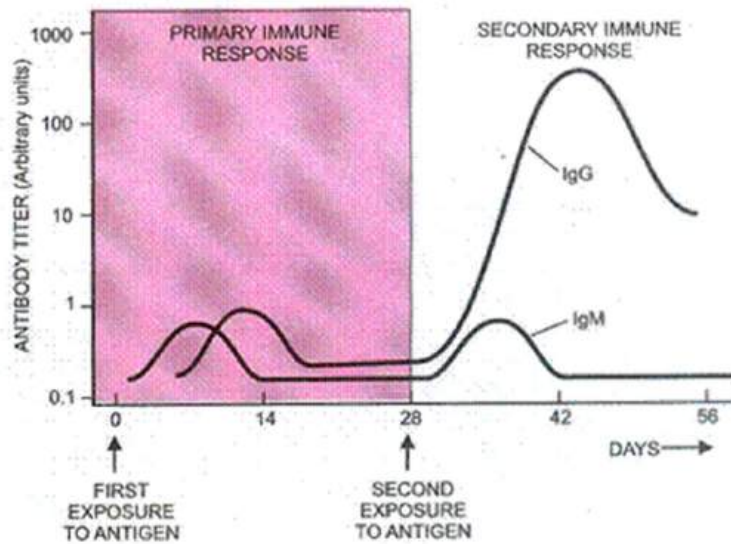

Production of antibodies in the primary and secondary responses to a given antigen.

(b) The secondary immune response:

Memory cells may remain in the body for decades. Every new encounter with the same antigen results in a rapid proliferation of memory cells. This is also called “booster response”. The antibody titer after subsequent encounters is far greater than during a primary response and consists mainly of IgG antibodies. This accelerated, more intense response is called the secondary immune response. Antibodies produced during a secondary response have an even higher affinity for the antigen.

A person who had been suffering from diseases like measles, small pox or chicken pox becomes immune to subsequent attacks of these diseases. It includes spleen, lymph nodes, tonsils, Peyer’s patches of small intestine and appendix.

The increased power and duration of the secondary immune response explain why immunization (method of providing immunity artificially, it is called vaccination) is usually accomplished by injecting antigen in multiple doses.

Difference between Innate and Adaptive Immunity

S.N.	Characteristics	Innate Immunity	Adaptive immunity
1.	Presence	Innate immunity is something already present in the body.	Adaptive immunity is created in response to exposure to a foreign substance.
2.	Specificity	Non-Specific	Specific
3.	Response	Fights any foreign invader	Fight only specific infection

4.	Response	Rapid	Slow (1-2 weeks)
5.	Potency	Limited and Lower potency	High potency
6.	Time span	Once activated against a specific type of antigen, the immunity remains throughout the life.	The span of developed immunity can be lifelong or short.
7.	Inheritance	Innate type of immunity is generally inherited from parents and passed to offspring.	Adaptive immunity is not passed from the parents to offspring, hence it cannot be inherited.
8.	Memory	Cannot react with equal potency upon repeated exposure to the same pathogen.	Adaptive system can remember the specific pathogens which have encountered before.
9.	Presence	Present at birth	Develops during a person's lifetime and can be short-lived.
10.	Allergic Reaction	None	Immediate and Delay hypersensitivity
11.	Used Against	For microbes	Microbes and non-microbial substances called antigens
12.	Memory	No memory	Long term memory
13.	Diversity	Limited	High
14.	Speed	Faster response	Slower response
15.	Complement system activation	Alternative and lectin pathways	Classical pathway

16.	Anatomic and physiological barriers	Skin, Mucous membranes, Temp, pH, chemicals, etc.	Lymph nodes, spleen, mucosal associated lymphoid tissue.
17.	Composition	The innate immune system is composed of physical and chemical barriers, phagocytic leukocytes, dendritic cells, natural killer cells, and plasma proteins.	Adaptive immune system is composed of B cells and T cells.
18.	Development	Evolutionary, older and is found in both vertebrates and invertebrates.	Adaptive immunity system has been developed recently and is found only in the vertebrates.
19.	Example	White blood cells fighting bacteria, causing redness and swelling, when you have a cut.	Chickenpox vaccination so that we don't get chickenpox because adaptive immunity system has remembered the foreign body.

(C) Haematopoiesis

Haematopoiesis (also hematopoiesis in American English; sometimes also haemopoiesis or hemopoiesis) is the formation of blood cellular components

Haemopoiesis or haematopoiesis is the process of formation of new blood cellular components. It has been estimated that in an adult human, approximately 10^{11} – 10^{12} new blood cells are produced daily in order to maintain steady state levels in the peripheral circulation. The mother cells from which the progeny daughter blood cells are generated are known as haematopoietic stem cells. In an embryo yolk sac is the main site of haemopoiesis whereas in human the basic sites where haemopoiesis occurs are the bone marrow (femur and tibia in infants; pelvis, cranium, vertebrae, and sternum of adults), liver, spleen and lymph nodes (Table 1). In other vertebrates haemopoiesis occurs in loose stroma of connective tissue of the gut, spleen, kidney or ovaries.

Table 1: Sites of Haemopoiesis in humans

Stage	Sites
Fetus	0–2 months (yolk sac)
	2–7 months (liver, spleen)
	5–9 months (bone marrow)
Infants	Bone marrow
Adults	Vertebrae, ribs, sternum, skull, sacrum and pelvis, proximal ends of femur

The process of haemopoiesis

Pluripotent stem cells with the capability of self renewal, in the bone marrow known as the haemopoiesis mother cell give rise to the separate blood cell lineages. This haemopoietic stem cell is rare, perhaps 1 in every 20 million nucleated cells in bone marrow. Figure 1 illustrates the bone marrow pluripotent stem cell and the cell lines that arise from it. Cell differentiation occurs from a committed progenitor haemopoietic stem cell and one stem cell is capable of producing about 10^6 mature blood cells after 20 cell divisions. The process leads to division of stem cells and commitment of each cell to differentiate into one of the different blood progenitor cells. The cell lineage chosen by the progenitor cells is a matter both chance and on the external stimuli received by progenitor cells. Internal transcription factors like PU.1 commits cells to the myeloid lineage whereas GATA-1 leads to erythropoietic and megakaryocytic differentiation. The proliferation and differentiation of haemopoietic progenitor cells and the function of mature blood cells is in turn regulated by glycoprotein hormones like Granulocyte colony stimulating factor or G-CSF. The growth factors may cause cell proliferation but can also stimulate differentiation, maturation, prevent apoptosis and affect the function of mature cells. The other growth factors that act at various levels of haemopoiesis are interleukin (IL-1 and IL-3); macrophage colony-stimulating factor; stem cell factor; and tumour necrosis factor (Table 2)

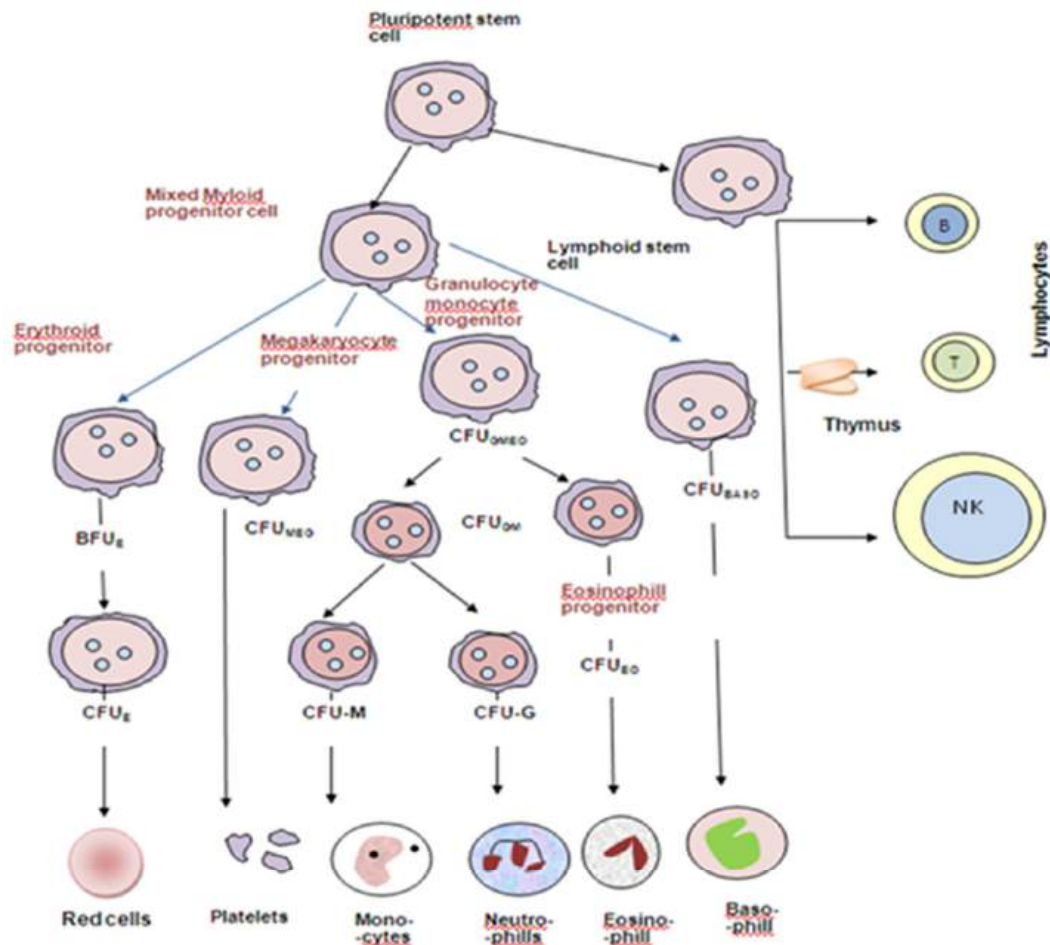

Figure 1: Diagrammatic representation of the bone marrow pluripotent stem cell and the cell lines that arise from it. Various progenitor cells can be identified by culture in semi-solid medium by the type of colony they form. Baso, basophil; BFU, burst-forming unit; CFU, colony-forming unit; E, erythroid; Eo, eosinophil; GM, granulocyte, monocyte; Meg, megakaryocyte; NK, natural killer cell (Hoffbrand et al. 2011).

Table 2 Growth factors in haemopoiesis

Acts On	Growth factor type
stromal cells	IL-1, TNF
pluripotential stem cells	SCF, Flt-L
multipotential progenitor cells	IL-3, GM-CSF, IL-6, G-CSF, Thrombopoietin
committed progenitor cells	G-CSF, M-CSF, IL-5, Thrombopoietin

Erythropoiesis

Erythropoiesis is the name for the process which leads to the formation of red blood cells (RBCs) or more properly termed as the erythrocytes. The normal life span of RBC's is about 120 days, thus new erythrocytes need to be formed. The overall process occurs in five days and the bone marrow is the site for the production of RBCs. A condition known as hypoxia which is shortage in RBC's oxygen carrying capacity leads to the release of the growth factor erythropoietin. Other growth factors which are released are IL-1, IL-4, IL-6, IL-11, IL-12, and SCF. Furthermore, Insulin, Growth hormone, and steroid hormones are very crucial in RBC production. EPO acts on precursor RBC cells which are Burst Forming Unit-Erythroid (BFUE) and Colony Forming Unit-Erythroid cells (CFUE) leading to their proliferation. The scheme given below summarizes the process of erythropoiesis. During sudden hypoxia due to massive blood loss the entire aforesaid process takes place in three days.

↓ O₂ tension → ↑ EPO → ↑ RBC's precursors (BFU-E and CFU-E) → ↑ differentiation & proliferation → ↑ mature RBC's release in 5 days.

They are six morphologically identifiable stages in erythroid differentiation which can be visualized under the microscope using Romanowsky (or Geimsa) stained slides. The different stages are namely:

- a. **Pronormoblasts:** These cells makes up about 1-2% of all nucleated cells in the bone marrow. The cytoplasm is very basophilic, i.e., has very dark blue color.
- b. **Basophilic normoblasts:** These cells constitutes up to 4% of all nucleated cells in the bone marrow. Under the microscope the cytoplasm shows deep blue color.
- c. **Polychromatophilic normoblasts:** These cells makes up to 10-20% of all nucleated cells in the bone marrow. The cytoplasm varies in color due to the synthesis of hemoglobin, which leads to a wide range of colors consisting of a mixture of gray, blue, mauve, and/or violet.
- d. **Orthochromic normoblasts:** The cytoplasm of these cells has a resultant color of pale grayish-blue-violet due to the presence of hemoglobin
- e. **Reticulocytes:** The retics appear slightly larger than normal erythrocytes, with a varying degree of color. The cytoplasm may be irregular and might have inclusions known as "basophilic stippling", which are the residual RNA remaining in the cells.
- f. **The mature erythrocyte (RBC):** The erythrocyte has a diameter of about 7μ and width of about 2μ. The cell lacks nucleus, and mitochondria.

Leucopoiesis

Leucopoiesis is the process by which white blood cells or lymphocytes (B-cells and T-cells) are produced and developed from the lymphoid progenitor cells, it is also known as leukocytopoiesis or lymphopoiesis. Lymphocytes are formed in the six constituents of the lymphomyeloid complex (LMC) which are namely the bone marrow, thymus, lymph nodes, subepithelial lymphoid tissue, spleen, connective tissue (including blood). The existence of specific markers on the lymphocyte membrane (CD-antigens) has enabled the differentiation of lymphocytic subpopulations. The largest number of the lymphocytes in the peripheral blood belongs to the subpopulations of the mature T-cells. A considerable smaller number of the lymphocytes belong to mature B-cells. The precursors of T- and B-cells are of the least number. Lymphoblast is the earliest morphologically recognizable cell of the lymphocytic lineage. During the lymphocytopoiesis, three developing cell forms can be seen. This process mainly comprises the formation of functional antigen receptors of the T-cells in the thymus and the ability to form and secrete immunoglobulins

by the B cells in the bone marrow. Leucopoiesis also results in development of natural killer cells (NKC). The process starts with the primitive reticular cell, which on activation develops into cytoplasmic basophilia and finally becomes a lymphoblast. A series of cell divisions (6-8 cell divisions) results in reduction in the amount of cytoplasm leading to the development of small lymphocyte.

B-cell development

B cell development occurs through several stages, each stage representing a change in the genome content at the antibody. When the B cell fails in any step of the maturation process, it will die by a mechanism called apoptosis. B cell leucopoiesis is dependent on the integration of extracellular stimuli by transcription factors that specify hematopoietic progenitors to differentiation into highly-specialized effector B-cells. The B cell factor-1 or Ebf1 is expressed in the early stages of the B cell lineage and in the stromal cells of the bone marrow. Ebf1 functions in a complex regulatory network with other transcription factors to establish the B cell program. B cell membrane receptors evolve and change throughout the B cell life span. Examples of such receptors are the TACI, BCMA and BAFF-R which are present on both immature B cells and mature B cells. CD20 is expressed on all stages of B cell development except the first and last; it is present from pre-B cells through memory cells, but not on either pre-pro-B cells or plasma cells. Figure 3 illustrates the stages of B-cell development.

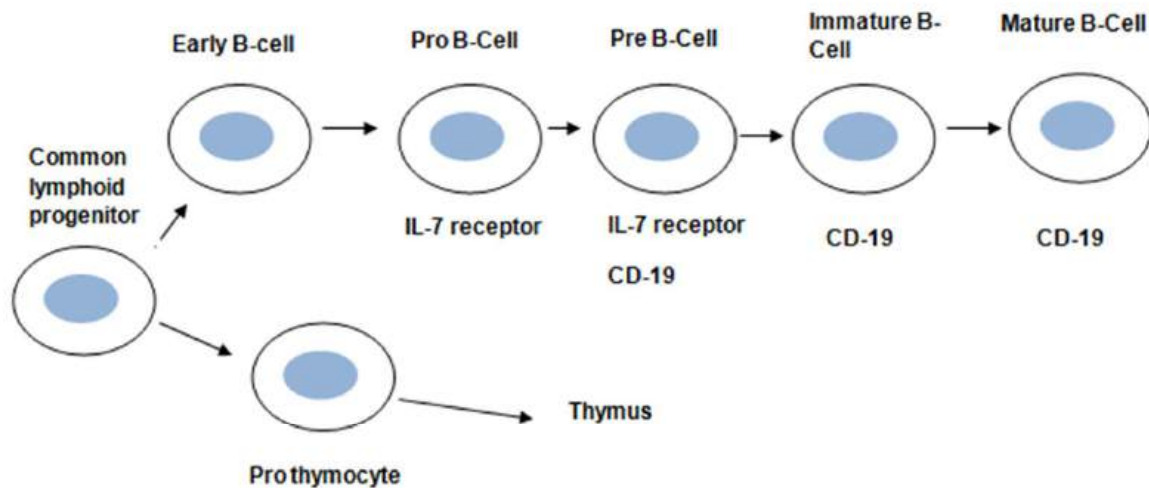

Figure 3: B cell developmental stages.

T-cell leucopoiesis

T cells are formed in bone marrow and then they migrate to the cortex of the thymus to undergo maturation in an antigen-free environment for about one week. About 2-4% of the T cells succeed to mature and the other 96-98% of T cells undergoes apoptosis and is phagocytosed by macrophages in the thymus. This process is termed as thymus education wherein T-cells capable of recognizing self antigens undergo apoptosis.

The mature forms of T-cells are:

1. T-helper: Activates other cells such as B cells and macrophages.
2. T-cytotoxic: Kills virally infected cells.
3. T-memory: Remembers previously encountered antigens.
4. T-suppressor cells: Moderates the immune response of other leukocytes.

1.4 Cells and organs of the immune system

The immune system is the complex collection of cells and organs that destroys or neutralizes pathogens that would otherwise cause disease or death. The lymphatic system, for most people, is associated with the immune system to such a degree that the two systems are virtually indistinguishable. The lymphatic system is the system of vessels, cells, and organs that carries excess fluids to the bloodstream and filters pathogens from the blood. The swelling of lymph nodes during an infection and the transport of lymphocytes via the lymphatic vessels are but two examples of the many connections between these critical organ systems.

Functions of the Lymphatic System

A major function of the lymphatic system is to drain body fluids and return them to the bloodstream. Blood pressure causes leakage of fluid from the capillaries, resulting in the accumulation of fluid in the interstitial space—that is, spaces between individual cells in the tissues. In humans, 20 liters of plasma is released into the interstitial space of the tissues each day due to capillary filtration. Once this filtrate is out of the bloodstream and in the tissue spaces, it is referred to as interstitial fluid. Of this, 17 liters is reabsorbed directly by the blood vessels. But what happens to the remaining three liters? This is where the lymphatic system comes into play. It drains the excess fluid and empties it back into the bloodstream via a series of vessels, trunks, and ducts. Lymph is the term used to describe interstitial fluid once it has entered the lymphatic system. When the lymphatic system is damaged in some way, such as by being blocked by cancer cells or destroyed by injury, protein-rich interstitial fluid accumulates (sometimes “backs up” from the lymph vessels) in the tissue spaces. This inappropriate accumulation of fluid referred to as lymphedema may lead to serious medical consequences.

As the vertebrate immune system evolved, the network of lymphatic vessels became convenient avenues for transporting the cells of the immune system. Additionally, the transport of dietary lipids and fat-soluble vitamins absorbed in the gut uses this system.

Cells of the immune system not only use lymphatic vessels to make their way from interstitial spaces back into the circulation, but they also use lymph nodes as major staging areas for the development of critical immune responses. A lymph node is one of the small, bean-shaped organs located throughout the lymphatic system.

Structure of the Lymphatic System

The lymphatic vessels begin as open-ended capillaries, which feed into larger and larger lymphatic vessels, and eventually empty into the bloodstream by a series of ducts. Along the way, the lymph travels through the lymph nodes, which are commonly found near the groin, armpits, neck, chest, and abdomen. Humans have about 500–600 lymph nodes throughout the body.

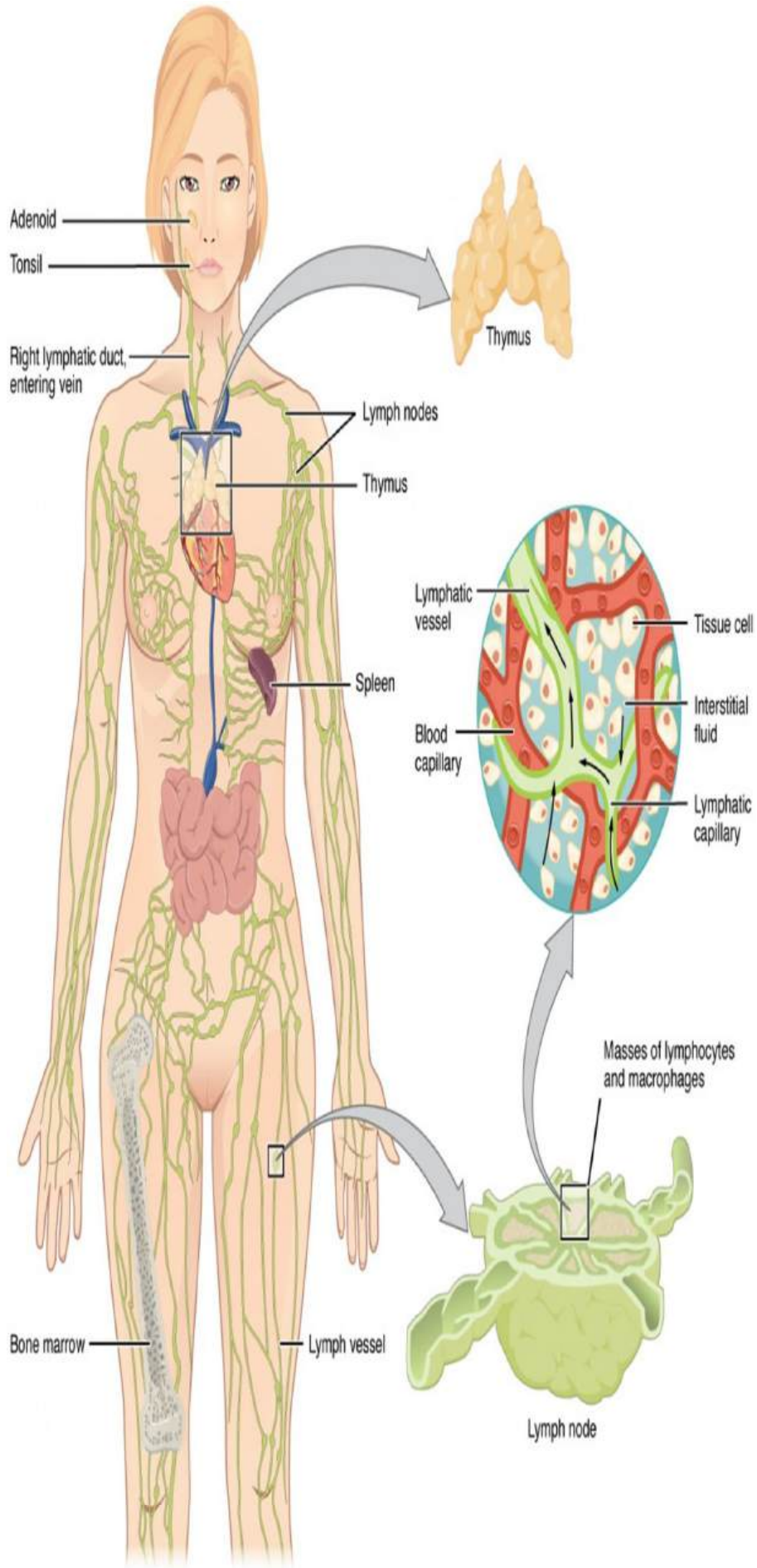

Figure 1. Lymphatic vessels in the arms and legs convey lymph to the larger lymphatic vessels in the torso.

A major distinction between the lymphatic and cardiovascular systems in humans is that lymph is not actively pumped by the heart, but is forced through the vessels by the movements of the body, the contraction of skeletal muscles during body movements, and breathing. One-way valves (semi-lunar valves) in lymphatic vessels keep the lymph moving toward the heart. Lymph flows from the lymphatic capillaries, through lymphatic vessels, and then is dumped into the circulatory system via the lymphatic ducts located at the junction of the jugular and subclavian veins in the neck.

Lymphatic Capillaries

Lymphatic capillaries, also called the terminal lymphatics, are vessels where interstitial fluid enters the lymphatic system to become lymph fluid. Located in almost every tissue in the body, these vessels are interlaced among the arterioles and venules of the circulatory system in the soft connective tissues of the body. Exceptions are the central nervous system, bone marrow, bones, teeth, and the cornea of the eye, which do not contain lymph vessels.

Lymph capillaries in the tissue spaces

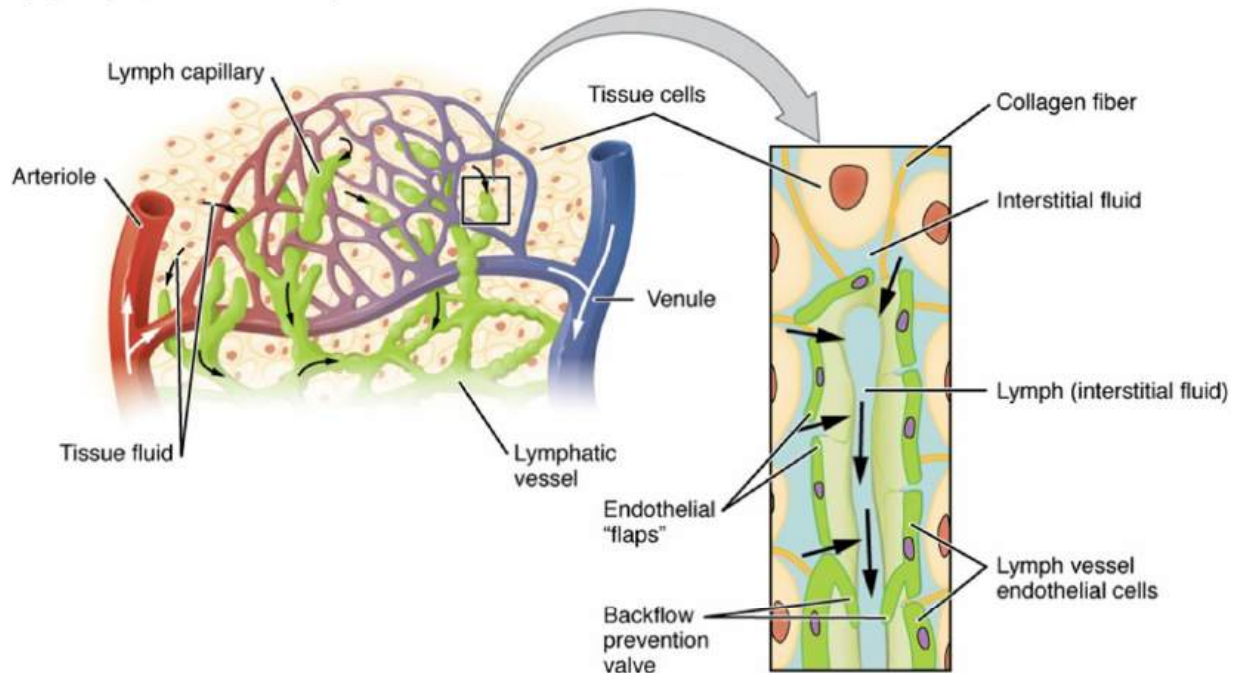

Figure 2. Lymphatic capillaries are interlaced with the arterioles and venules of the cardiovascular system. Collagen fibers anchor a lymphatic capillary in the tissue (inset). Interstitial fluid slips through spaces between the overlapping endothelial cells that compose the lymphatic capillary.

Lymphatic capillaries are formed by a one cell-thick layer of endothelial cells and represent the open end of the system, allowing interstitial fluid to flow into them via overlapping cells. When interstitial pressure is low, the endothelial flaps close to prevent “backflow.” As interstitial pressure increases, the spaces between the cells open up, allowing the fluid to enter. Entry of fluid into lymphatic capillaries is also enabled by the collagen filaments that anchor the capillaries to surrounding structures. As interstitial pressure increases, the filaments pull on the endothelial cell flaps, opening up them even further to allow easy entry of fluid.

In the small intestine, lymphatic capillaries called lacteals are critical for the transport of dietary lipids and lipid-soluble vitamins to the bloodstream. In the small intestine, dietary triglycerides combine with other lipids and proteins, and enter the lacteals to form a milky fluid called **chyle**. The chyle then travels through the lymphatic system, eventually entering the liver and then the bloodstream.

Larger Lymphatic Vessels, Trunks, and Ducts

The lymphatic capillaries empty into larger lymphatic vessels, which are similar to veins in terms of their three-tunic structure and the presence of valves. These one-way valves are located fairly close to one another, and each one causes a bulge in the lymphatic vessel, giving the vessels a beaded appearance.

The superficial and deep lymphatics eventually merge to form larger lymphatic vessels known as **lymphatic trunks**. On the right side of the body, the right sides of the head, thorax, and right upper limb drain lymph fluid into the right subclavian vein via the right lymphatic duct. On the left side of the body, the remaining portions of the body drain into the larger thoracic duct, which drains into the left subclavian vein. The thoracic duct itself begins just beneath the diaphragm in the **cisterna chyli**, a sac-like chamber that receives lymph from the lower abdomen, pelvis, and lower limbs by way of the left and right lumbar trunks and the intestinal trunk.

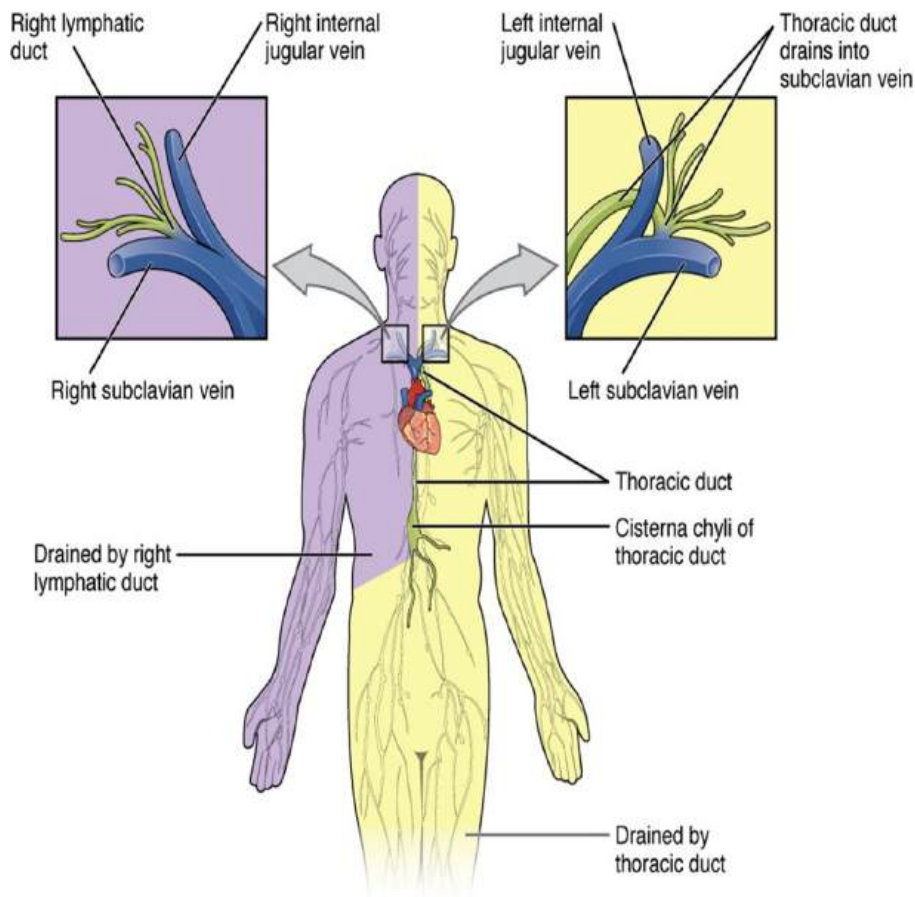

Figure 3. The thoracic duct drains a much larger portion of the body than does the right lymphatic duct.

The overall drainage system of the body is asymmetrical. The **right lymphatic duct** receives lymph from only the upper right side of the body. The lymph from the rest of the body enters the bloodstream through the **thoracic duct** via all the remaining lymphatic trunks. In general, lymphatic vessels of the subcutaneous tissues of the skin, that is, the superficial lymphatics, follow the same routes as veins, whereas the deep lymphatic vessels of the viscera generally follow the paths of arteries.

The Organization of Immune Function

The immune system is a collection of barriers, cells, and soluble proteins that interact and communicate with each other in extraordinarily complex ways. The modern model of immune function is organized into three phases based on the timing of their effects. The three temporal phases consist of the following:

- **Barrier defenses** such as the skin and mucous membranes, which act instantaneously to prevent pathogenic invasion into the body tissues
- The rapid but nonspecific **innate immune response**, which consists of a variety of specialized cells and soluble factors
- The slower but more specific and effective **adaptive immune response**, which involves many cell types and soluble factors, but is primarily controlled by white blood cells (leukocytes) known as **lymphocytes**, which help control immune responses

The cells of the blood, including all those involved in the immune response, arise in the bone marrow via various differentiation pathways from hematopoietic stem cells. In contrast with embryonic stem cells, hematopoietic stem cells are present throughout adulthood and allow for the continuous differentiation of blood cells to replace those lost to age or function. These cells can be divided into three classes based on function:

- Phagocytic cells, which ingest pathogens to destroy them
- Lymphocytes, which specifically coordinate the activities of adaptive immunity
- Cells containing cytoplasmic granules, which help mediate immune responses against parasites and intracellular pathogens such as viruses

The cells of immune system are:

1. Lymphocytes-

- T-lymphocytes
- B- lymphocytes
- NK cell

2. Phagocytic cells

- Monocytes
- Macrophages

3. Granulocytic cells

- Neutrophils

- Basophils
- Eosinophils

4. Dendritic cells

Lymphocytes

As stated above, lymphocytes are the primary cells of adaptive immune responses (see Table 1 for more details). The two basic types of lymphocytes, B cells and T cells, are identical morphologically with a large central nucleus surrounded by a thin layer of cytoplasm. They are distinguished from each other by their surface protein markers as well as by the molecules they secrete. While B cells mature in red bone marrow and T cells mature in the thymus, they both initially develop from bone marrow. T cells migrate from bone marrow to the thymus gland where they further mature. B cells and T cells are found in many parts of the body, circulating in the bloodstream and lymph, and residing in secondary lymphoid organs, including the spleen and lymph nodes, which will be described later in this section. The human body contains approximately 10^{12} lymphocytes.

B Cells

B cells are immune cells that function primarily by producing antibodies. An **antibody** is any of the group of proteins that binds specifically to pathogen-associated molecules known as antigens. An **antigen** is a chemical structure on the surface of a pathogen that binds to T or B lymphocyte antigen receptors. Once activated by binding to antigen, B cells differentiate into cells that secrete a soluble form of their surface antibodies. These activated B cells are known as plasma cells.

T Cells

The **T cell**, on the other hand, does not secrete antibody but performs a variety of functions in the adaptive immune response. Different T cell types have the ability to either secrete soluble factors that communicate with other cells of the adaptive immune response or destroy cells infected with intracellular pathogens. The roles of T and B lymphocytes in the adaptive immune response will be discussed further in this chapter.

Plasma Cells

Another type of lymphocyte of importance is the plasma cell. A **plasma cell** is a B cell that has differentiated in response to antigen binding, and has thereby gained the ability to secrete soluble antibodies. These cells differ in morphology from standard B and T cells in that they contain a large amount of cytoplasm packed with the protein-synthesizing machinery known as rough endoplasmic reticulum.

Natural Killer Cells

A fourth important lymphocyte is the natural killer cell, a participant in the innate immune response. A **natural killer cell (NK)** is a circulating blood cell that contains cytotoxic (cell-killing) granules in its extensive cytoplasm. It shares this mechanism with the cytotoxic T cells of the adaptive immune response. NK cells are among the body's first lines of defense against viruses and certain types of cancer.

Phagocytic cells:

- Monocytes and macrophages are mononuclear phagocytic cells.

- Granulocyte-monocyte progenitor cell differentiates into promonocytes and neutrophil.
- Promonocytes leaves the bone marrow and enter into blood stream where they differentiate into mature monocytes.
- Monocytes circulates in blood for about 8 hours, during which they enlarges and then enter into tissues and differentiates into specific macrophages and dendritic cells.

1. Monocytes:

- Blood monocytes measure 12-15 μm with a single lobed kidney shaped nucleus.
- It accounts for (2-8%) of blood leucocytes.

Immunological Functions of monocytes:

- Helps in antigen processing and presentation
- Releases cytokines
- Specialized function in tissues
- Cytotoxicity

2. Macrophages:

- Monocyte migrates to tissue and differentiates into macrophages.
- Differentiation of monocytes into macrophages involves following changes:
- Cell enlarges 5-10 folds
- Intracellular granules increases in number and complexity
- Increase phagocytic ability
- Produces higher level of hydrolytic enzymes and cytokines
- Macrophages serve different functions in different tissues.
- Alveolar macrophages : in lungs
- Histiocyte: connective tissue
- Kuffer cell: liver
- Messangial cell: kidney
- Microglial cell: brain
- Osteoclast: bone

Immunological functions of macrophages:

- Phagocytosis
- Antigen presentation to T-cell
- Secretion of lymphokines IL-1, IL-6. IL-12. TNF- α etc to activates inflammatory response
- Secretion of granulocyte monocyte colony (GMC) stimulating factors.

II. Granulocytic cells:

1. Neutrophil:

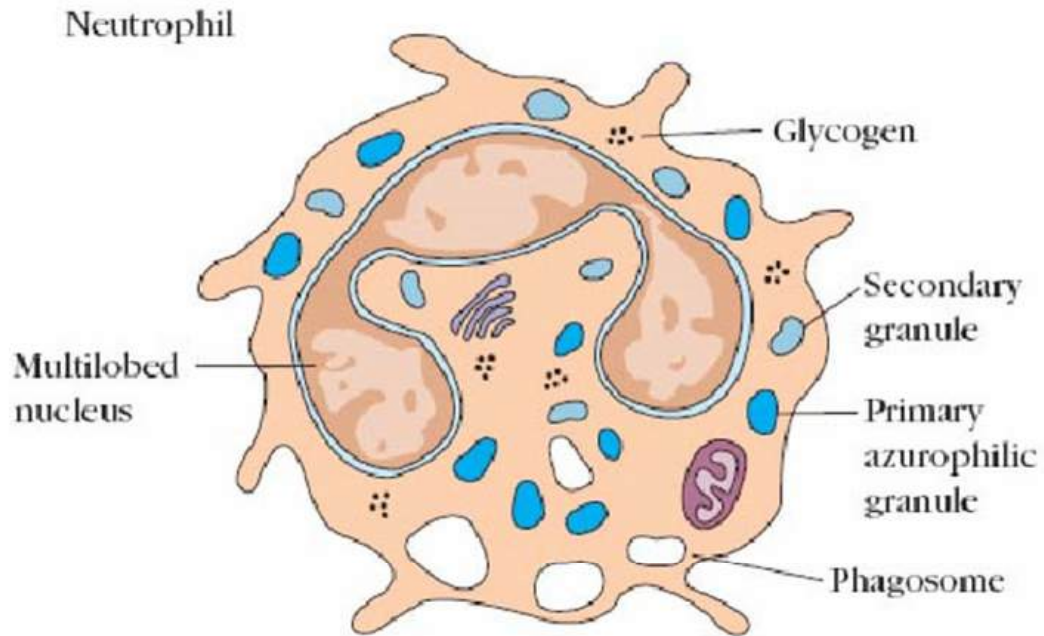

source;slideshare

- Neutrophils are (11-14 μ m) in diameter with multilobed nucleus with granules in cytoplasm.
- It constitutes 50-70 % of total circulating WBC and remains for 7-8 hours in blood and then migrates to tissues
- Life span is 3-4 days.
- Also known as polymorphonuclear (PMN) leucocyte.
- Neutrophils is stained by both acidic and basic dye.

Immunological functions of Neutrophil:

- Phagocytic role in acute inflammatory response.
- It is the first immune cell to responds in inflammation.

2. Eosinophils:

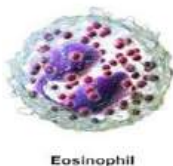

- Eosinophils are (11-15 μ m) in diameter, heavily granulated with bilobed nucleus
- It is stained by acidic dye ie Eosin
- They are phagocytic and motile

Immunological functions of Eosinophil:

- Granules contain various hydrolytic enzymes that kill parasites which are too large to be phagocytosed by neutrophils.
- Provide allergic inflammation

3. Basophils:

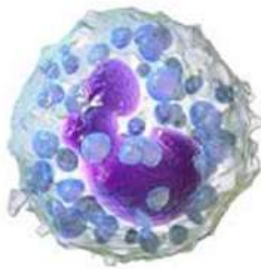

Basophil

- Basophils are non-phagocytic cell found in small number in blood and tissue
- Cytoplasm contains large number of prominent basophilic granules containing histamine, heparin, serotonin, and other hydrolytic enzymes
- Stained by basic dyes

Immunological functions:

- Provide anaphylactic and atopic allergic reaction

IV. Dendritic cell:

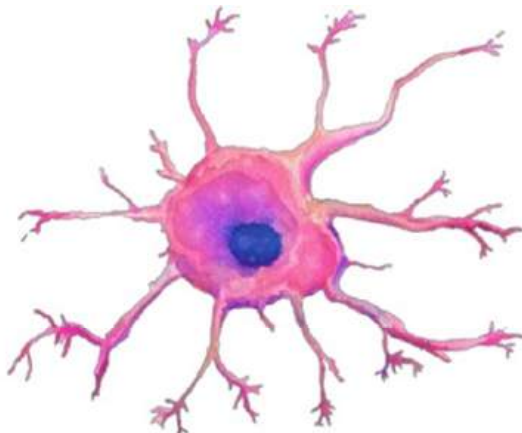

- Dendritic cells have long cytoplasmic extensions that resembles to dendrites of nerve cell.
- They have highly pleomorphic with a small central body and many long needle like processes.
- Dendritic cells are antigen presenting cell (APC) because they possess MHC class.

Immunological functions:

- Involved in antigen presentation to T-cells during primary immune response.
- Very little role in phagocytosis.

Primary Lymphoid Organs and Lymphocyte Development

Understanding the differentiation and development of B and T cells is critical to the understanding of the adaptive immune response. It is through this process that the body (ideally) learns to destroy only pathogens and leaves the body's own cells relatively intact. The primary lymphoid organs are the bone marrow, spleen, and thymus gland. The lymphoid organs are where lymphocytes mature, proliferate, and are selected, which enables them to attack pathogens without harming the cells of the body.

Bone Marrow

In the embryo, blood cells are made in the yolk sac. As development proceeds, this function is taken over by the spleen, lymph nodes, and liver. Later, the bone marrow takes over most hematopoietic functions, although the final stages of the differentiation of some cells may take place in other organs. The red bone marrow is a loose collection of cells where hematopoiesis occurs, and the yellow bone marrow is a site of energy storage, which consists largely of fat cells. The B cell undergoes nearly all of its development in the red bone marrow, whereas the immature T cell, called a thymocyte, leaves the bone marrow and matures largely in the thymus gland.

Thymus

The thymus gland is a bilobed organ found in the space between the sternum and the aorta of the heart. Connective tissue holds the lobes closely together but also separates them and forms a capsule.

The left panel of this figure shows the head and chest of a woman and the location of the thymus is marked. The top right panel shows a micrograph of the thymus and the bottom right panel shows a magnified view of the structure of the thymus.

The connective tissue capsule further divides the thymus into lobules via extensions called trabeculae. The outer region of the organ is known as the cortex and contains large numbers of thymocytes with some epithelial cells, macrophages, and dendritic cells (two types of phagocytic cells that are derived from monocytes). The cortex is densely packed so it stains more intensely than the rest of the thymus. The medulla, where thymocytes migrate before leaving the thymus, contains a less dense collection of thymocytes, epithelial cells, and dendritic cells.

Secondary Lymphoid Organs and their Roles in Active Immune Responses

Lymphocytes develop and mature in the primary lymphoid organs, but they mount immune responses from the **secondary lymphoid organs**. A **naïve lymphocyte** is one that has left the primary organ and entered a secondary lymphoid organ. Naïve lymphocytes are fully functional

immunologically, but have yet to encounter an antigen to respond to. In addition to circulating in the blood and lymph, lymphocytes concentrate in secondary lymphoid organs, which include the lymph nodes, spleen, and lymphoid nodules. All of these tissues have many features in common, including the following:

- The presence of lymphoid follicles, the sites of the formation of lymphocytes, with specific B cell-rich and T cell-rich areas
- An internal structure of reticular fibers with associated fixed macrophages
- **Germinal centers**, which are the sites of rapidly dividing B lymphocytes and plasma cells, with the exception of the spleen
- Specialized post-capillary vessels known as **high endothelial venules**; the cells lining these venules are thicker and more columnar than normal endothelial cells, which allow cells from the blood to directly enter these tissues

Lymph Nodes

Lymph nodes function to remove debris and pathogens from the lymph, and are thus sometimes referred to as the “filters of the lymph”. Any bacteria that infect the interstitial fluid are taken up by the lymphatic capillaries and transported to a regional lymph node. Dendritic cells and macrophages within this organ internalize and kill many of the pathogens that pass through, thereby removing them from the body. The lymph node is also the site of adaptive immune responses mediated by T cells, B cells, and accessory cells of the adaptive immune system. Like the thymus, the bean-shaped lymph nodes are surrounded by a tough capsule of connective tissue and are separated into compartments by trabeculae, the extensions of the capsule. In addition to the structure provided by the capsule and trabeculae, the structural support of the lymph node is provided by a series of reticular fibers laid down by fibroblasts.

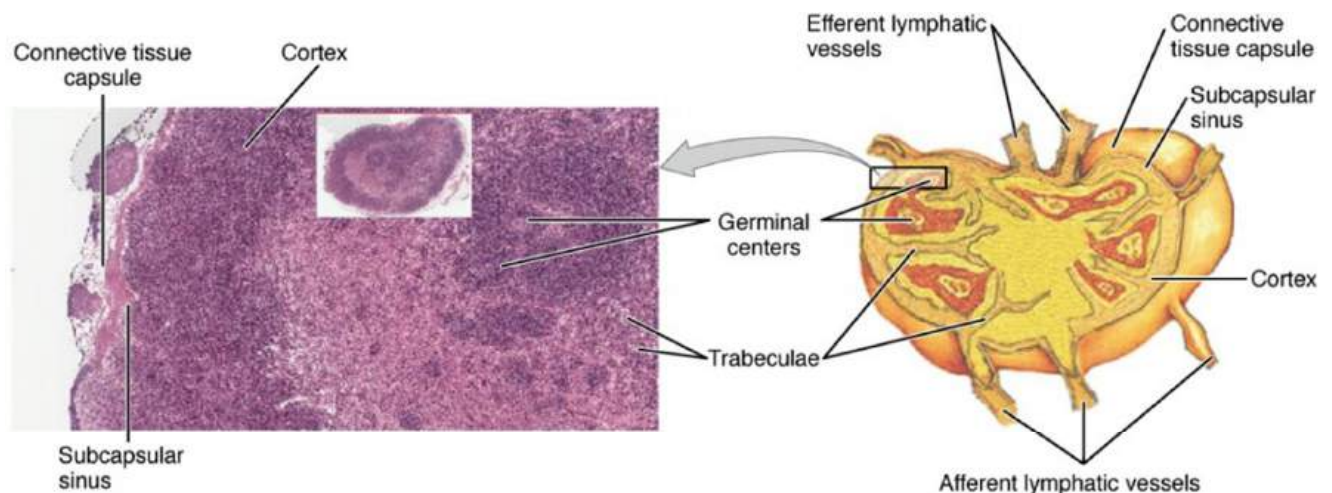

The major routes into the lymph node are via **afferent lymphatic vessels**. Cells and lymph fluid that leave the lymph node may do so by another set of vessels known as the **efferent lymphatic vessels**. Lymph enters the lymph node via the subcapsular sinus, which is occupied by dendritic cells, macrophages, and reticular fibers. Within the cortex of the lymph node are lymphoid follicles, which consist of germinal centers of rapidly dividing B cells surrounded by a layer of T cells and other accessory cells. As the lymph continues to flow through the node, it enters the medulla, which

consists of medullary cords of B cells and plasma cells, and the medullary sinuses where the lymph collects before leaving the node via the efferent lymphatic vessels.

Spleen

In addition to the lymph nodes, the **spleen** is a major secondary lymphoid organ. It is about 12 cm (5 in) long and is attached to the lateral border of the stomach via the gastrosplenic ligament. The spleen is a fragile organ without a strong capsule, and is dark red due to its extensive vascularization. The spleen is sometimes called the “filter of the blood” because of its extensive vascularization and the presence of macrophages and dendritic cells that remove microbes and other materials from the blood, including dying red blood cells. The spleen also functions as the location of immune responses to blood-borne pathogens.

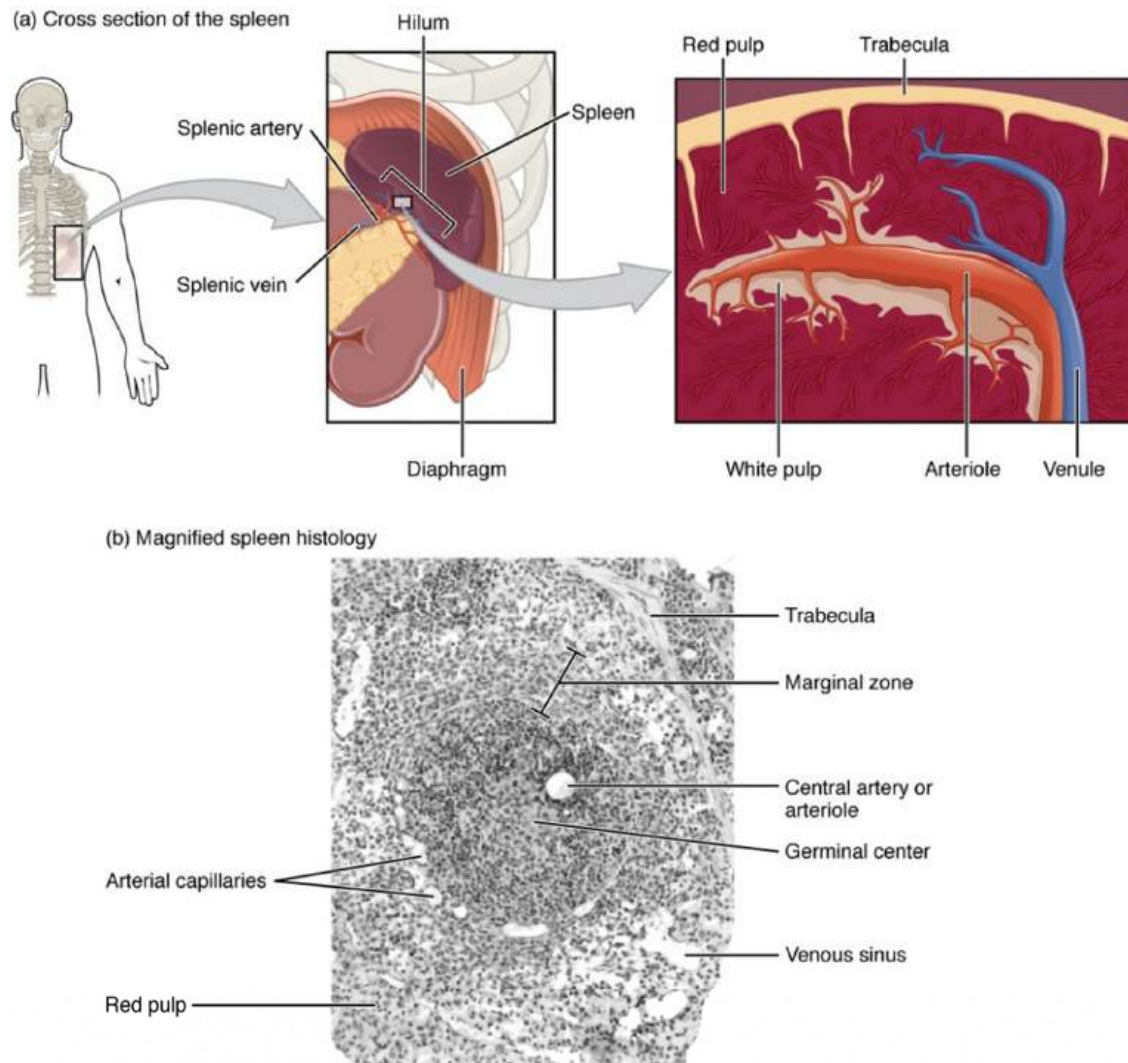

The spleen is also divided by trabeculae of connective tissue, and within each splenic nodule is an area of red pulp, consisting of mostly red blood cells, and white pulp, which resembles the lymphoid follicles of the lymph nodes. Upon entering the spleen, the splenic artery splits into several arterioles (surrounded by white pulp) and eventually into sinusoids. Blood from the capillaries subsequently collects in the venous sinuses and leaves via the splenic vein. The red pulp consists of reticular fibers with fixed macrophages attached, free macrophages, and all of the other cells typical of the blood,

including some lymphocytes. The white pulp surrounds a central arteriole and consists of germinal centers of dividing B cells surrounded by T cells and accessory cells, including macrophages and dendritic cells. Thus, the red pulp primarily functions as a filtration system of the blood, using cells of the relatively nonspecific immune response, and white pulp is where adaptive T and B cell responses are mounted.

Lymphoid Nodules

The other lymphoid tissues, the **lymphoid nodules**, have a simpler architecture than the spleen and lymph nodes in that they consist of a dense cluster of lymphocytes without a surrounding fibrous capsule. These nodules are located in the respiratory and digestive tracts, areas routinely exposed to environmental pathogens.

Tonsils are lymphoid nodules located along the inner surface of the pharynx and are important in developing immunity to oral pathogens. The tonsil located at the back of the throat, the pharyngeal tonsil, is sometimes referred to as the adenoid when swollen. Such swelling is an indication of an active immune response to infection. Histologically, tonsils do not contain a complete capsule, and the epithelial layer invaginates deeply into the interior of the tonsil to form tonsillar crypts. These structures, which accumulate all sorts of materials taken into the body through eating and breathing, actually “encourage” pathogens to penetrate deep into the tonsillar tissues where they are acted upon by numerous lymphoid follicles and eliminated. This seems to be the major function of tonsils—to help children’s bodies recognize, destroy, and develop immunity to common environmental pathogens so that they will be protected in their later lives. Tonsils are often removed in those children who have recurring throat infections, especially those involving the palatine tonsils on either side of the throat, whose swelling may interfere with their breathing and/or swallowing.

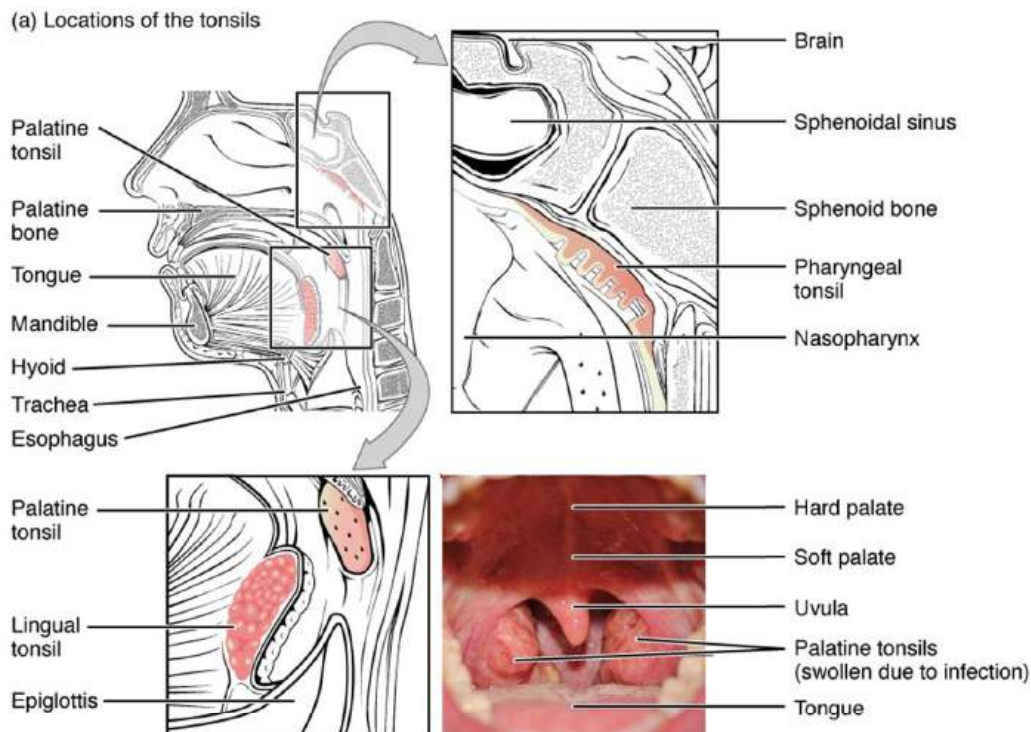

Mucosa-associated lymphoid tissue (MALT) consists of an aggregate of lymphoid follicles directly associated with the mucous membrane epithelia. MALT makes up dome-shaped structures found underlying the mucosa of the gastrointestinal tract, breast tissue, lungs, and eyes. Peyer's patches, a type of MALT in the small intestine, are especially important for immune responses against ingested substances. Peyer's patches contain specialized endothelial cells called M (or microfold) cells that sample material from the intestinal lumen and transport it to nearby follicles so that adaptive immune responses to potential pathogens can be mounted.

Figure 10. LM \times 40. (Micrograph provided by the Regents of the University of Michigan Medical School \copyright 2012)

Bronchus-associated lymphoid tissue (BALT) consists of lymphoid follicular structures with an overlying epithelial layer found along the bifurcations of the bronchi, and between bronchi and arteries. They also have the typically less-organized structure of other lymphoid nodules. These tissues, in addition to the tonsils, are effective against inhaled pathogens.

6th SEMESTER

ZOO616DA: ZOOLOGY – IMMUNOLOGY

Unit 2nd

1.1 Basic properties of antigens.

Classically, an antigen is defined as an organism, a molecule, or part of a molecule or substance which may be self or non-self, can evoke noticeable immune response and can bound distinctively with antibodies. Antigenicity is the ability of antigen to combine specifically with the final products of immune system i.e., either with antibodies or with cell surface receptors.

Antigens, which are able to induce adaptive immunity, are called immunogens. All immunogens are antigens unless their ability to stimulate an immune response is significant.

Nature of Antigens:

Any foreign agent can act as an antigen, so antigen is of numerous type which is really endless. Antigen may be a chemical substance like a protein or a polysaccharide. It may be a biological entity like, Bacteria, bacterial products, fungi, parasites, viruses, different microbes, or a larger parasites.

Immune system can recognize any macro- molecules of an infectious agent, either proteins or polysaccharides. Proteins are recognized as a potent immunogens whereas polysaccharides are second in position. Sometimes lipids and nucleic acids may be treated as infectious agent when these are attached with proteins or polysaccharides.

Besides these, different biological products— milk, egg albumin, bee venom, snake venom, pollen grains may be a good source of antigen. Different parts of bacterial cells like flagella, pili, lipopolysaccharides of outer membrane of Gram- negative bacteria, the capsular polysaccharides of the cell membrane, cytoplasmic proteins, exotoxins, endotoxins etc. can have antigenic property and can evoke immune response against them.

Sometimes (normally very rare); self-protein can be recognized as non-self by body and can be treated as foreign substances against which body will take necessary steps to control the anomalies (called as auto-immune disease).

Classification of Antigens:

Antigens can be classified under two major categories, called:

(1) Exogenous and

(2) Endogenous antigens.

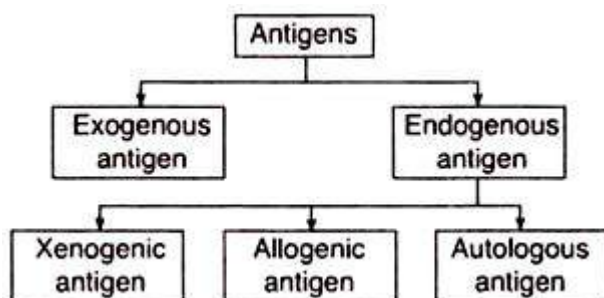

1. Exogenous antigens:

Exogenous antigens are those antigens which enter within the host body from their surroundings or external environments. These are basically of pollutants, microorganisms, pollens, drugs etc. Different infectious diseases, are caused by these type of introduced or foreign external agents are normally called communicable diseases, e.g., influenza virus, malarial protozoa etc.

2. Endogenous antigens:

These types of antigens are located within the individual itself.

Endogenous antigens are again classified under three sub-categories named as:

- i. Xeno-genic or Heterogenic antigens
- ii. Allogenic or Idiotypic antigens
- iii. Autologous antigens.

i. Xeno-genic antigens:

Xeno-genic antigens are those groups of foreign items which are related with tissue transplantation and serology. Normally, these are called heterogenic antigens as they are related with phylogenetically unrelated species.

When a piece of tissue or graft is transplanted to an individual, it may be treated as foreign, then those molecules are considered as xeno-antigens. Similar foreign recognition may be resulted in serology. Cross-reactions are very common in between antisera to certain erythrocytic surface antigens or some bacterial antigens.

Antisera is formed against surface antigens. Produced antisera cross-react with cells or body fluids of animals belonging to different species due to presence of mucopolysaccharide and lipid based chemical determinants.

ii. Allogenic antigens:

Allogenic antigens are those antigens which are genetically determined, polymorphic in nature and help to differentiate one individual of one species from another individual belonging to the same species. When an individual (recipient) receives a blood transfusion or undergoes transplantation operation (like plastic surgery, kidney etc.)

These phenomena lead to incompatibility, agglutination and graft rejection. In case of human beings these types of antigenic determinants are located on erythrocytes, leukocytes, platelets, cell surface markers, serum proteins and histocompatibility antigens.

iii. Autologous antigens:

This group of antigens is very rare and unnatural. In normal condition, self-components are non-immunogenic in nature, but in an abnormal condition self-body components are started to be considered as non-self or antigenic component.

Essential Features of Antigens:

There are two essential features found within the antigenic molecules:

1. The molecules must be recognized as foreign by the host.

2. After antigen processing, antigens must undergo some physical and chemical changes that can stimulate the immune system.

Factors that influence Immunogenicity (Antigenicity):

Immunogens play a pivotal role in determining the status of immune system. Immune system always try to recognize foreign invaders and also try to get rid of antigenic effect.

Somehow, the body must recognize a foreign substance in order to evoke an immune response:

There are some essential factors which influence the power of antigen

Those are:

- i. Molecular size,
- ii. Structural stability,
- iii. Degradability,
- iv. Foreignness,
- v. Chemical composition and heterogeneity,
- vi. Antigen processing and presentation,
- vii. Conformation and
- viii. Accessibility.

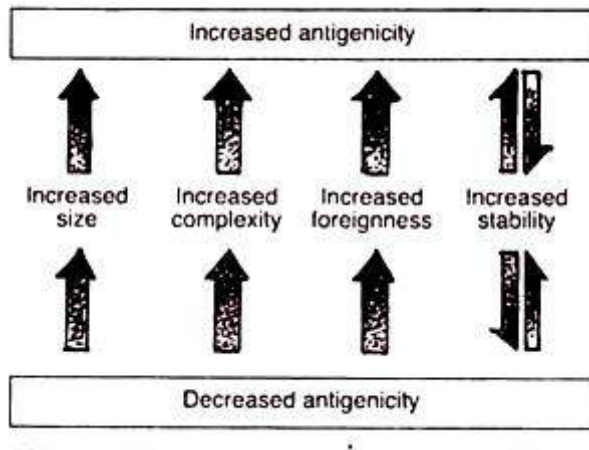

i. Molecular size:

In general, large molecules are better antigens than small molecules. There is a direct correlation between the size of molecules and immunogenicity

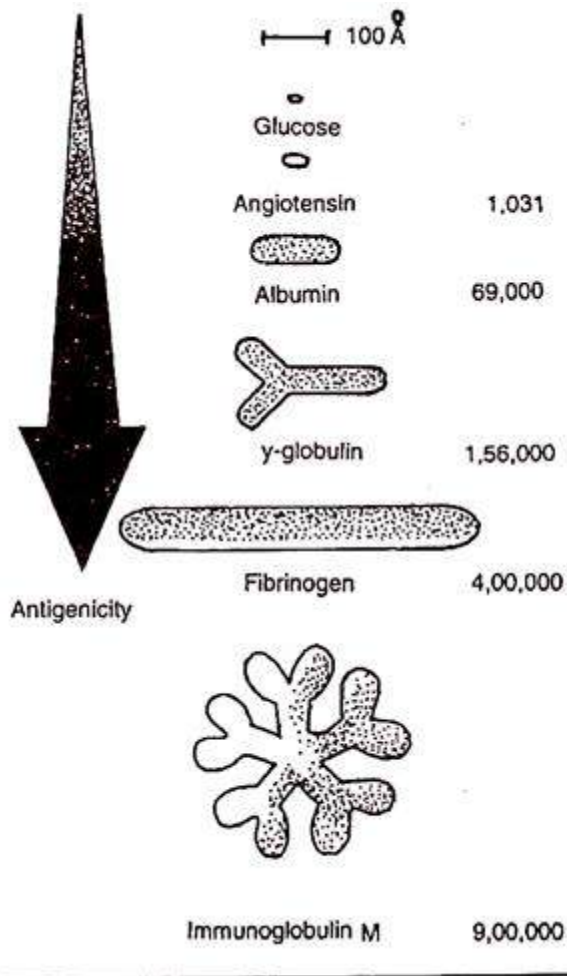

As for example, hemocyanin is an invertebrate blood protein with (6.7×10^3) kDa molecular size, is a potent antigen in nature. Serum albumin from other mammals (69 kDa) is a fairly good antigen but may also provoke tolerance, whereas the hormone angiotensin (1031 Da) is a poor antigen.

Sometimes, very small molecules may bind to large proteins and resulting in formation of active antigen which can evoke an immune system. The best immunogens tend to have a molecular mass approaching 100000Da.

ii. Structural stability:

The recognition of a molecule or part of a molecule as foreign is possible by the cells of the immune system due to its specific shape. Those molecules are recognized as poor antigens which lack a specific or fixed shape. As for example gelatin is recognized as a poor protein due to its structural instability. This is being stabilized by cross-linking of the peptide chain with tyrosine or tryptophan.

The major protein of bacterial flagellum called flagellin is a weak antigen due to its unstable structure; it is being enhanced by polymerization. Proteins are much more stable antigens than starch (polysaccharide), lipids, carbohydrates and nucleic-acids.

iii. Degradability:

Easy degradation of an antigenic molecule is considered as an important factor with respect to their antigenicity. The cells of the immune system recognize small molecular fragments and soluble antigens. When a molecule does not undergo breakdown process, it can not be considered as antigen.

For e.g., stainless steel pins and plastic joints are commonly implanted in the body without triggering an immune response. Different metals or organic polymers, plastic cannot be fragmented and processed to form suitable for triggering an immune response.

Conversely, since immune responses are antigen driven, foreign molecules are very rapidly destroyed on entering the body may not provide sufficient stable antigen fragments to stimulate an immune response.

iv. Foreignness:

The first and foremost criteria for a molecule to function as an immunogen is that it must be or act as non-self to the host. The cells, whose function is to respond to antigen (antigen-sensitive cells) are selected in such a way that they do not usually respond to normal body components.

The degree of immunogenicity depends upon the degree of foreignness of the immunogen. When an antigen is introduced into an organism, greater the phylogenetic distance between two species, the greater the genetic (i.e. antigenic) disparity between them. But all foreign substances do not elicit immune response.

As for e.g. carbon granules evoke phagocytosis but not antibody production. But the bovine serum albumin (BSA) is an excellent immunogen when it is injected into a rabbit or other mammals but not at all an immunogen when it is introduced within the blood of cow itself. A kidney graft from an identical twin will be readily accepted but a graft from an unrelated human will be rejected in about two weeks and a graft from a chimpanzee to a human will be rejected within a few hours due to disparity of protein structure and firmness with respect to evolutionary stand point view.

v. Chemical composition and heterogeneity:

Not only molecular size, structural stability and foreignness but also chemical composition of an immunogen is an effective factor which affects its immunogenicity. As for e.g. artificial or synthetic homopolymers tend to lack immunogenicity regardless of their size. Copolymers of sufficient size, containing two or more different amino acids are immunogenic.

The addition of aromatic amino acids, such as tyrosine or phenylalanine has immense effect on the immunogenicity of these synthetic polymer. As for e.g. a synthetic copolymer of glutamic acid and lysine requires a minimum molecular wt. of 30,000-40,000 for immunogenicity. Besides chemical compositions, structural complexity and heterogeneity of protein affect immunogenicity. Starting from nascent to final stage, proteins undergo four levels of organization called primary, secondary, tertiary and quaternary protein, which gradually add their structural complexity and impose effect on their immunogenicity

vi. Antigen processing and presentation:

There is a great variety of antigens found within the body. Some antigens are readily be recognized by immune system (mainly by B-cells) and some require to be processed and presented in a presentable manner so that they can be recognized by immune cells (T-cells usually). There are intracellular (endogenous) and extracellular (exogenous) antigens which present different challenges to the immune system. A foreign protein (antigen) to be recognized by a T-cell must be degraded into small antigenic peptides that form physical complex with Class I or Class II Major Histocompatibility Complex (MHC) molecules. This conversion of proteins into MHC associated peptide fragments is called antigen processing and presentation. This processing of antigens is mediated by different antigen cells of the body.

2.2 B and T cell epitopes, haptens and adjuvants

Immunogen and Antigen

Immunogen is a stimulus that produces a humoral or cell-mediated immune response, whereas antigens are any substance that binds specifically to an antibody or a T-cell receptor. All immunogens are antigens, but all antigens may not be immunogens, some very small molecules called haptens can bind to antibodies or B-cell receptor but they cannot initiate an immune response.

Epitopes

An epitope, also known as antigenic determinant, is the part of an antigen that is recognized by the immune system, specifically by antibodies, B cells, or T cells. For example, the epitope is the specific piece of the antigen to which an antibody binds. The part of an antibody that binds to the epitope is called a paratope. Although epitopes are usually non-self proteins, sequences derived from the host that can be recognized (as in the case of autoimmune diseases) are also epitopes.

An antibody that is specific for an antigen binds non-covalently to a region of the molecule surface known as epitope.

Naturally occurring epitopes are relatively small (either amino-acids or sugar residues). Specific epitope should fit with the specific site present on antibody (antibody-binding site).

The site present on antibody called antigen- combining site or paratope is a cave pocket shaped one to match with the epitope having a convex site (Fig. 4.8).

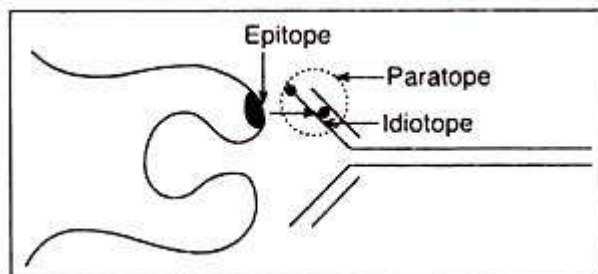

Small antigens are mainly mono-epitopic where as large proteins and oligosaccharides can express many different and/or identical repeating multi-epitopes.

The forces responsible for binding include hydrophobic and Vander Waals forces, which are spherical, symmetrical and hydrogen bridges, which are directional and require matching of the reactants. Electrostatic forces might also contribute, but they act at distance.

Formation of stable immune complexes normally occur only when the epitope and paratope fit 'Jigsaw Fashion'.

Not only the position of on epitope within a large molecule is important in determining its ability to induce an immune response, but the position of each subunit within the epitope may also be important. For e.g. each of the amino acid residues comprising a given accessible epitope might unequally contribute to bind with an antibody paratope. Thus some components of an epitope are more immuno-dominant than others.

Any amino acid can contribute to a protein epitope. The residues that are not part of the epitope might not bind to antibody but might influence antigen conformation and affect epitope binding. Substitution of even a single amino acid in an epitope can affect binding of antibody.

The recognition of antigens by T cells and B cells is fundamentally different. B cells recognize soluble antigen when it binds to their membrane-bound antibody. Because B cells bind antigen that is free in solution, the epitopes they recognize tend to be highly accessible sites on the exposed surface of the immunogen. As noted previously, most T cells recognize only peptides combined with MHC molecules on the surface of antigen-presenting cells and altered self-cells; T-cell epitopes, as a rule, cannot be considered apart from their associated MHC molecules.

ADJUVANTS

Adjuvants (from Latin *adjuvare*, to help) are substances that, when mixed with an antigen and injected with it, enhance the immunogenicity of that antigen. Adjuvants are often used to boost the immune response when an antigen has low immunogenicity or when only small amounts of an antigen are available. For example, the antibody response of mice to immunization with BSA can be increased fivefold or more if the BSA is administered with an adjuvant. Precisely how adjuvants augment the immune response is not entirely known, but they appear to exert one or more of the following effects

- Antigen persistence is prolonged.
- Co-stimulatory signals are enhanced.
- Local inflammation is increased.
- The nonspecific proliferation of lymphocytes is stimulated.

Aluminum potassium sulfate (alum) prolongs the persistence of antigen. When an antigen is mixed with alum, the salt precipitates the antigen. Injection of this alum precipitate results in a slower release of antigen from the injection site, so that the effective time of exposure to the antigen increases from a few days without adjuvant to several weeks with the adjuvant. The alum precipitate also increases the size of the antigen, thus increasing the likelihood of phagocytosis. Water-in-oil adjuvants also prolong the persistence of antigen. A preparation known as Freund's incomplete adjuvant contains antigen in aqueous solution, mineral oil, and an emulsifying agent such as mannide mono oleate, which disperses the oil into small droplets surrounding the antigen; the antigen is then released very slowly from the site of injection. This preparation is based on Freund's complete adjuvant, the first deliberately formulated highly effective adjuvant, developed by Jules Freund many years ago and containing heat-killed *Mycobacteria* as an additional ingredient. Muramyl dipeptide, a component of the mycobacterial cell wall, activates macrophages, making

Freund's complete adjuvant far more potent than the incomplete form. Activated macrophages are more phagocytic than unactivated macrophages and express higher levels of class II MHC molecules and the membrane molecules of the B7 family. The increased expression of class II MHC increases the ability of the antigen-presenting cell to present antigen to TH cells. B7 molecules on the antigen presenting cell bind to CD28, a cell-surface protein on TH cells, triggering co-stimulation, an enhancement of the T cell immune response. Thus, antigen presentation and the requisite co-stimulatory signal usually are increased in the presence of adjuvant. Alum and Freund's adjuvants also stimulate a local, chronic inflammatory response that attracts both phagocytes and lymphocytes. This infiltration of cells at the site of the adjuvant injection often results in formation of a dense, macrophage-rich mass of cells called a granuloma. Because the macrophages in a granuloma are activated, this mechanism also enhances the activation of TH cells. Other adjuvants (e.g., synthetic

polyribonucleotides and bacterial lipopolysaccharides) stimulate the nonspecific proliferation of lymphocytes and thus increase the likelihood of antigen-induced clonal selection of lymphocytes.

Hapten

The pioneering work of Karl Landsteiner in the 1920s and 1930s created a simple, chemically defined system for studying the binding of an individual antibody to a unique epitope on a complex protein antigen. Landsteiner employed various haptens, small organic molecules that are antigenic but not immunogenic. Chemical coupling of a hapten to a large protein, called a carrier, yields an immunogenic hapten-carrier conjugate. Animals immunized with such a conjugate produce antibodies specific for (1) the hapten determinant, (2) unaltered epitopes on the carrier protein, and (3) new epitopes formed by combined parts of both the hapten and carrier (Figure 3-10). By itself, a hapten cannot function as an immunogenic epitope. But when multiple molecules of a single hapten are coupled to a carrier protein (or nonimmunogenic homopolymer), the hapten becomes accessible to the immune system and can function as an immunogen. The beauty of the hapten-carrier system is that it provides immunologists with a chemically defined determinant that can be subtly modified by chemical means to determine the effect of various chemical structures on immune specificity. In his studies, Landsteiner immunized rabbits with a hapten-carrier conjugate and then tested the reactivity of the rabbit's immune sera with that hapten and with closely related haptens coupled to a different carrier protein.

The first haptens used were aniline and its carboxyl derivatives (o-, m-, and p-aminobenzoic acid). One well-known hapten is urushiol, the toxin found in poison ivy and a common cause of cell-mediated contact dermatitis. When absorbed through the skin from a poison ivy plant, urushiol undergoes oxidation in the skin cells to generate the actual hapten, a reactive molecule called a quinone, which then reacts with skin proteins to form hapten adducts. Usually, the first exposure causes only sensitization, in which there is a proliferation of helper and cytotoxic T cells. After a second exposure, the proliferated T cells can become activated, generating an immune reaction and producing the characteristic blisters of poison ivy exposure.

Fluorescein is an example of a hapten used in molecular biology.

Some haptens induce autoimmune disease. An example is hydralazine, a blood pressure-lowering drug that occasionally causes lupus erythematosus (an autoimmune inflammatory disorder) in certain individuals with genetic predispositions to the disease. This also appears to be the mechanism by which the anesthetic gas halothane can cause life-threatening hepatitis and penicillin-class drugs cause autoimmune hemolytic anemia. Other haptens, such as fluorescein, detect proteins with which they form adducts. This makes them a common part of molecular biology lab techniques.

Complete Antigens

A complete antigen is essentially a hapten-carrier adduct. Once the body has generated antibodies to a hapten-carrier adduct, the small-molecule hapten may also be able to bind to the antibody, but will usually not initiate an immune response. In most cases this can only be elicited by the only the hapten-carrier adduct. Sometimes the small-molecule hapten can block immune response to the complete antigen by preventing the adduct from binding to the antibody, a process called hapten inhibition. In this case, the hapten acts as the epitope for the antigen, which binds to the antibodies without causing a response. If this happens with enough haptens, there will not be enough antibodies left to bind to the complete antigen, thus inhibiting the antibody response.

2.3 Structure, classes and functions of antibodies. Monoclonal antibodies

Antibodies, often termed 'immunoglobulins', are glycoproteins that bind antigens with high specificity and affinity.

Structure

Antibodies are heavy (~150 kDa) globular plasma proteins. The size of an antibody molecule is about 10 nm. They have sugar chains (glycans) added to conserved amino acid residues. In other words, antibodies are glycoproteins. The attached glycans are critically important to the structure and function of the antibody. Among other things the expressed glycans can modulate an antibody's affinity for its corresponding FcR(s).

The basic functional unit of each antibody is an immunoglobulin (Ig) monomer (containing only one Ig unit); secreted antibodies can also be dimeric with two Ig units as with IgA, tetrameric with four Ig units like teleost fish IgM, or pentameric with five Ig units, like mammalian IgM.

Several immunoglobulin domains make up the two heavy chains (red and blue) and the two light chains (green and yellow) of an antibody. The immunoglobulin domains are composed of between 7 (for constant domains) and 9 (for variable domains) β -strands.

The variable parts of an antibody are its V regions, and the constant part is its C region.

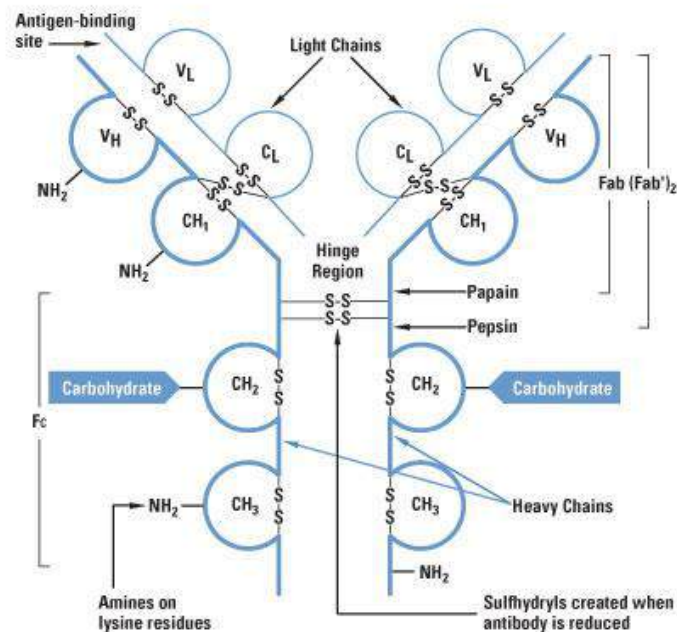

Immunoglobulin domains

The Ig monomer is a "Y"-shaped molecule that consists of four polypeptide chains; two identical heavy chains and two identical light chains connected by disulfide bonds. Each chain is composed of structural domains called immunoglobulin domains. These domains contain about 70–110 amino acids and are classified into different categories (for example, variable or IgV, and constant or IgC) according to their size and function. They have a characteristic immunoglobulin fold in which two beta sheets create a "sandwich" shape, held together by interactions between conserved cysteines and other charged amino acids.

Heavy chain

There are five types of mammalian Ig heavy chain denoted by the Greek letters: α , δ , ϵ , γ , and μ . The type of heavy chain present defines the class of antibody; these chains are found in IgA, IgD, IgE, IgG, and IgM antibodies, respectively. Distinct heavy chains differ in size and composition; α and γ contain approximately 450 amino acids, whereas μ and ϵ have approximately 550 amino acids.

Each heavy chain has two regions, the constant region and the variable region. The constant region is identical in all antibodies of the same isotype, but differs in antibodies of different isotypes. Heavy chains γ , α and δ have a constant region composed of three tandem (in a line) Ig domains, and a hinge region for added flexibility; heavy chains μ and ϵ have a constant region composed of four immunoglobulin domains. The variable region of the heavy chain differs in antibodies produced by different B cells, but is the same for all antibodies produced by a single B cell or B cell clone. The variable region of each heavy chain is approximately 110 amino acids long and is composed of a single Ig domain.

Light chain

In mammals there are two types of immunoglobulin light chain, which are called lambda (λ) and kappa (κ). A light chain has two successive domains: one constant domain and one variable domain. The approximate length of a light chain is 211 to 217 amino acids. Each antibody contains two light chains that are always identical; only one type of light chain, κ or λ , is present per antibody in mammals. Other types of light chains, such as the iota (ι) chain, are found in other vertebrates like sharks (Chondrichthyes) and bony fishes (Teleostei).

CDRs, Fv, Fab and Fc regions

Some parts of an antibody have the same functions. The arms of the Y, for example, contain the sites that can bind to antigens (in general, identical) and, therefore, recognize specific foreign objects. This region of the antibody is called the Fab (fragment, antigen-binding) region. It is composed of one constant and one variable domain from each heavy and light chain of the antibody. The paratope is shaped at the amino terminal end of the antibody monomer by the variable domains from the heavy and light chains. The variable domain is also referred to as the FV region and is the most important region for binding to antigens. To be specific, variable loops of β -strands, three each on the light (VL) and heavy (VH) chains are responsible for binding to the antigen. These loops are referred to as the complementarity determining regions (CDRs). The structures of these CDRs have been clustered and classified by Chothia et al. and more recently by North et al. and Nikoloudis et al. In the framework of the immune network theory, CDRs are also called idiotypes. According to immune network theory, the adaptive immune system is regulated by interactions between idiotypes.

In summary, the Fab region of the antibody determines antigen specificity while the Fc region of the antibody determines the antibody's class effect. Since only the constant domains of the heavy chains make up the Fc region of an antibody, the classes of heavy chain in antibodies determine their class effects. Possible classes of heavy chains in antibodies include alpha, gamma, delta, epsilon, and mu, and they define the antibody's isotypes IgA, G, D, E, and M, respectively. This infers different isotypes of antibodies have different class effects due to their different Fc regions binding and activating different types of receptors. Possible class effects of antibodies include: Opsonisation, agglutination, haemolysis, complement activation, mast cell degranulation, and neutralisation (though this class effect may be mediated by the Fab region rather than the Fc region). It also implies that Fab-mediated effects are directed at microbes or toxins, whilst Fc mediated effects are directed at effector cells or effector molecules.

Classes of Immunoglobulins:

1. IgG:

It is the major class of serum immunoglobulins. It takes part in various antibacterial, antiviral and antitoxic activities. It passes through placenta and gives passive immunity to the new born child for about six months.

2. IgM:

It is roughly less than 10% of normal serum immunoglobulins. It is made up of five-four-chain subunits. Its molecular weight is 900,000 Daltons. IgM develops primary immunity against most antigens. IgM antibodies are effective against toxins from diphtheria, tetanus, botulism, anthrax, snake venoms.

3. IgA:

IgA antibody is about 13 to 15% of the total Igs in human serum. It is a predominant immunoglobulin in body serum and secretions e.g. saliva, tears, nasal fluids, sweat, colostrum, milk and lung secretions, gastrointestinal and genitourinary secretions. Here it provides defence against microorganisms.

Amniotic fluid also has IgA and it provides passive immunity to the foetus. Serum IgA contains several types of antibodies including isoagglutinins, antibodies of anti-diphtheria, anti-Brucella, anti-insulin and antipoliomyelitis.

Secretory IgA is structurally different from serum IgA. Serum IgA does not pass from serum to exocrine glands or to other mucosal sites. Serum IgA is produced by plasma cells in the bone marrow and Secretory IgA is produced by local plasma cells distributed in Secretory tissues.

4. IgD:

It is found in traces in human serum, i.e. about 1% of total serum Igs. It was first discovered in the serum of patients of myeloma tumors or malignant lymphomas. Its function is not yet established. Its structure is like that of IgG having two L chains and two H chains joined by S-S bonds. Its molecular weight is about 180,000 Daltons.

5. IgE:

IgE in normal serum is lowest amongst all other Igs. Its molecular weight is about 200,000 Daltons. It has also two L chains and two H chains joined by one S-S bonds. Allergens stimulate the plasma cells for the synthesis of IgE antibodies.

Igs are also further sub divided into subclasses. Such as IgG1, IgG2, IgG3 and IgG4 and each of them have a distinct H chain. IgM has IgM1 and IgM2. IgA is also classified into IgA1 and IgA2.

Immunoglobulins are highly antigenic or immunogenic. Antibodies can be produced against different classes or subclasses of Igs, after injecting them into another heterologus species. The different Igs differ in antigenic determinants mainly on A-chains. The differences are mainly due to amino acid sequences.

Antibody Functions

Differentiated plasma cells are crucial players in the humoral response, and the antibodies they secrete are particularly significant against extracellular pathogens and toxins. Antibodies circulate freely and act independently of plasma cells. Antibodies can be transferred from one individual to

another to temporarily protect against infectious disease. For instance, a person who has recently produced a successful immune response against a particular disease agent can donate blood to a nonimmune recipient and confer temporary immunity through antibodies in the donor's blood serum. This phenomenon is called **passive immunity**; it also occurs naturally during breastfeeding, which makes breastfed infants highly resistant to infections during the first few months of life.

Antibodies coat extracellular pathogens and neutralize them, as illustrated in Figure 3, by blocking key sites on the pathogen that enhance their infectivity (such as receptors that “dock” pathogens on host cells). Antibody neutralization can prevent pathogens from entering and infecting host cells, as opposed to the CTL-mediated approach of killing cells that are already infected to prevent progression of an established infection. The neutralized antibody-coated pathogens can then be filtered by the spleen and eliminated in urine or feces.

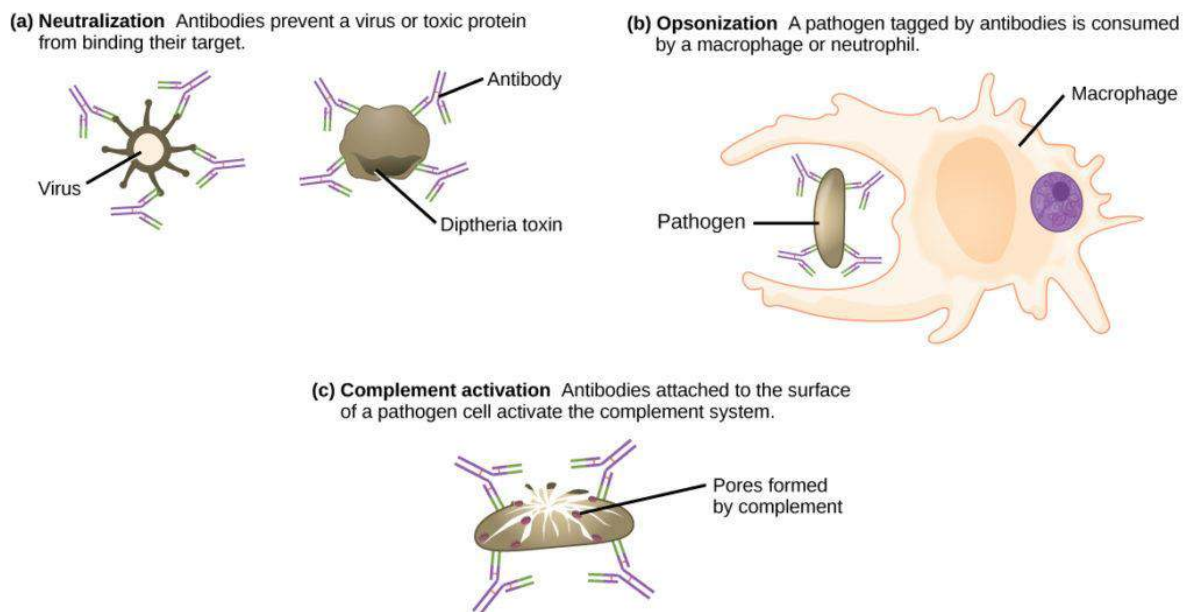

Figure 3. Antibodies may inhibit infection by (a) preventing the antigen from binding its target, (b) tagging a pathogen for destruction by macrophages or neutrophils, or (c) activating the complement cascade.

Antibodies also mark pathogens for destruction by phagocytic cells, such as macrophages or neutrophils, because phagocytic cells are highly attracted to macromolecules complexed with antibodies. Phagocytic enhancement by antibodies is called opsonization. In a process called complement fixation, IgM and IgG in serum bind to antigens and provide docking sites onto which sequential complement proteins can bind. The combination of antibodies and complement enhances opsonization even further and promotes rapid clearing of pathogens.

Affinity, Avidity, and Cross Reactivity

Not all antibodies bind with the same strength, specificity, and stability. In fact, antibodies exhibit different **affinities** (attraction) depending on the molecular complementarity between antigen and antibody molecules, as illustrated in Figure 4. An antibody with a higher affinity for a particular antigen would bind more strongly and stably, and thus would be expected to present a more challenging defense against the pathogen corresponding to the specific antigen.

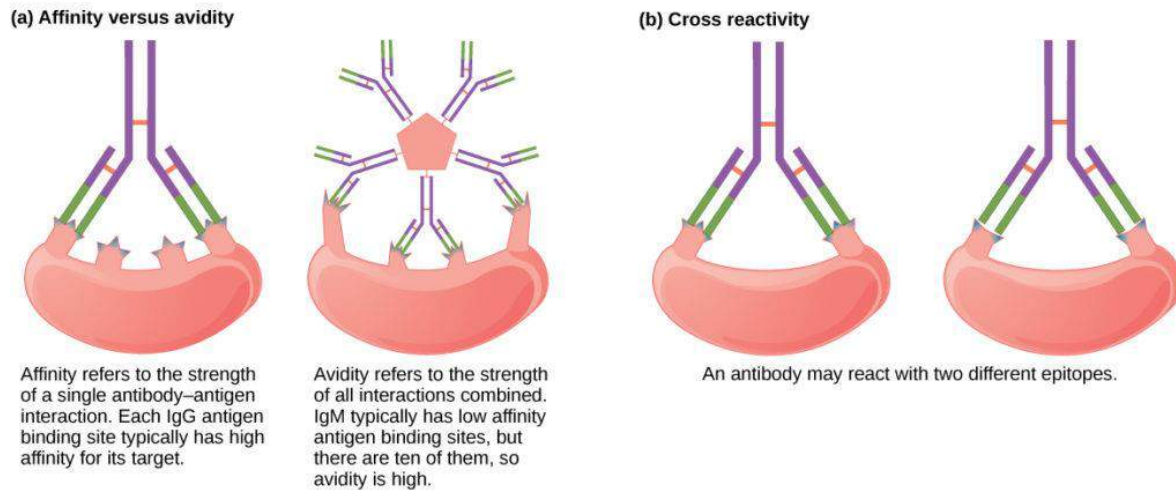

Figure 4. (a) Affinity refers to the strength of single interaction between antigen and antibody, while avidity refers to the strength of all interactions combined. (b) An antibody may cross react with different epitopes.

The term **avidity** describes binding by antibody classes that are secreted as joined, multivalent structures (such as IgM and IgA). Although avidity measures the strength of binding, just as affinity does, the avidity is not simply the sum of the affinities of the antibodies in a multimeric structure. The avidity depends on the number of identical binding sites on the antigen being detected, as well as other physical and chemical factors. Typically, multimeric antibodies, such as pentameric IgM, are classified as having lower affinity than monomeric antibodies, but high avidity. Essentially, the fact that multimeric antibodies can bind many antigens simultaneously balances their slightly lower binding strength for each antibody/antigen interaction.

Antibodies secreted after binding to one epitope on an antigen may exhibit cross reactivity for the same or similar epitopes on different antigens. Because an epitope corresponds to such a small region (the surface area of about four to six amino acids), it is possible for different macromolecules to exhibit the same molecular identities and orientations over short regions. **Cross reactivity** describes when an antibody binds not to the antigen that elicited its synthesis and secretion, but to a different antigen.

Cross reactivity can be beneficial if an individual develops immunity to several related pathogens despite having only been exposed to or vaccinated against one of them. For instance, antibody cross reactivity may occur against the similar surface structures of various Gram-negative bacteria. Conversely, antibodies raised against pathogenic molecular components that resemble self molecules may incorrectly mark host cells for destruction and cause autoimmune damage. Patients who develop systemic lupus erythematosus (SLE) commonly exhibit antibodies that react with their own DNA. These antibodies may have been initially raised against the nucleic acid of microorganisms but later cross-reacted with self-antigens. This phenomenon is also called molecular mimicry.

Monoclonal Antibodies

Monoclonal antibodies (mAb or moAb) are antibodies that are made by identical immune cells that are all clones of a unique parent cell. Monoclonal antibodies can have monovalent affinity, in that they bind to the same epitope (the part of an antigen that is recognized by the antibody). In contrast, polyclonal antibodies bind to multiple epitopes and are usually made by several different plasma cell (antibody secreting immune cell) lineages. Bispecific monoclonal antibodies can also be engineered, by increasing the therapeutic targets of one single monoclonal antibody to two epitopes.

It is interesting that immortal monoclonal antibody producing cells do exist in nature. They are found in the patients suffering from a disease called multiple myeloma (a cancer of B- lymphocytes). It was in 1975. George Kohler and Cesar Milstein (Nobel Prize, 1984) achieved large scale production of MAbs. They could successfully hybridize antibody—producing B-lymphocytes with myeloma cells in vitro and create a hybridoma.

The result is that the artificially immortalized B-lymphocytes can multiply indefinitely in vitro and produce MAbs. The hybridoma cells possess the growth and multiplying properties of myeloma cells but secrete antibody of B-lymphocytes. The production of monoclonal antibodies by the hybrid cells is referred to as hybridoma technology.

Production of Monoclonal Antibodies:

The establishment of hybridomas and production of MAbs involves the following steps (Fig. 17.2).

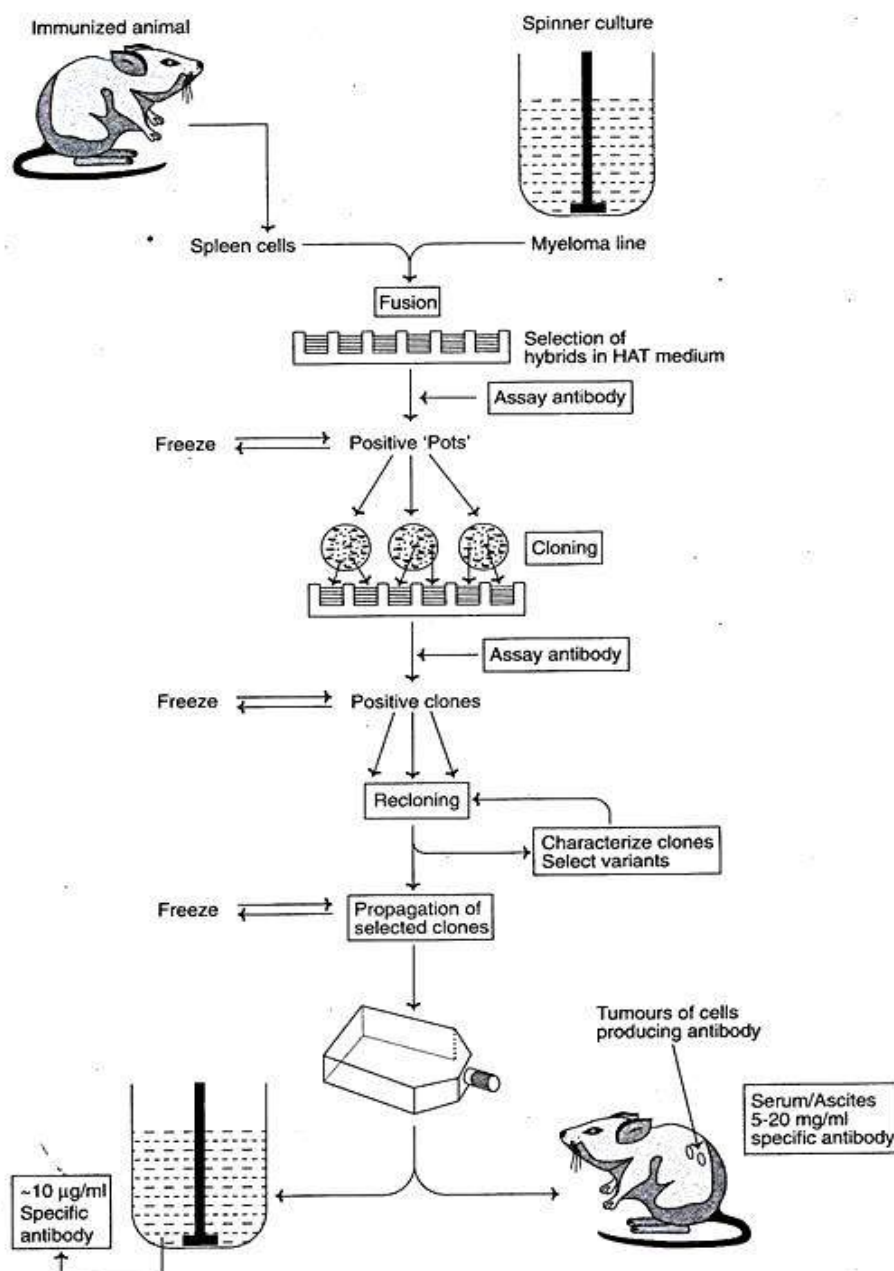

1. Immunization
2. Cell fusion
3. Selection of hybridomas
4. Screening the products
5. Cloning and propagation
6. Characterization and storage.

1. Immunization:

The very first step in hybridoma technology is to immunize an animal (usually a mouse), with appropriate antigen. The antigen, along with an adjuvant like Freund's complete or incomplete adjuvant is injected subcutaneously (adjuvants are non-specific potentiators of specific immune responses). The injections at multiple sites are repeated several times.

This enables increased stimulation of B-lymphocytes which are responding to the antigen. Three days prior to killing of the animal, a final dose of antigen is intravenously administered. The immune-stimulated cells for synthesis of antibodies have grown maximally by this approach. The concentration of the desired antibodies is assayed in the serum of the animal at frequent intervals during the course of immunization.

When the serum concentration of the antibodies is optimal, the animal is sacrificed. The spleen is aseptically removed and disrupted by mechanical or enzymatic methods to release the cells. The lymphocytes of the spleen are separated from the rest of the cells by density gradient centrifugation.

2. Cell Fusion:

The thoroughly washed lymphocytes are mixed with HGPRT defective myeloma cells. The mixture of cells is exposed to polyethylene glycol (PEG) for a short period (a few minutes), since it is toxic. PEG is removed by washing and the cells are kept in a fresh medium. These cells are composed of a mixture of hybridomas (fused cells), free myeloma cells and free lymphocytes.

3. Selection of Hybridomas:

When the cells are cultured in HAT medium (the principle described above), only the hybridoma cells grow, while the rest will slowly disappear. This happens in 7-10 days of culture. Selection of a single antibody producing hybrid cells is very important. This is possible if the hybridomas are isolated and grown individually. The suspension of hybridoma cells is so diluted that the individual aliquots contain on an average one cell each. These cells, when grown in a regular culture medium, produce the desired antibody.

4. Screening the Products:

The hybridomas must be screened for the secretion of the antibody of desired specificity. The culture medium from each hybridoma culture is periodically tested for the desired antibody specificity. The two techniques namely ELISA and RIA are commonly used for this purpose.

In both the assays, the antibody binds to the specific antigen (usually coated to plastic plates) and the unbound antibody and other components of the medium can be washed off. Thus, the hybridoma cells producing the desired antibody can be identified by screening. The antibody secreted by the hybrid cells is referred to as monoclonal antibody.

5. Cloning and Propagation:

The single hybrid cells producing the desired antibody are isolated and cloned. Two techniques are commonly employed for cloning hybrid cells-limiting dilution method and soft agar method.

Limiting dilution method:

In this procedure, the suspension of hybridoma cells is serially diluted and the aliquots of each dilution are put into micro culture wells. The dilutions are so made that each aliquot in a well contains only a single hybrid cell. This ensures that the antibody produced is monoclonal.

Soft agar method:

In this technique, the hybridoma cells are cultured in soft agar. It is possible to simultaneously grow many cells in semisolid medium to form colonies. These colonies will be monoclonal in nature. In actual practice, both the above techniques are combined and used for maximal production of MAbs.

6. Characterization and Storage:

The monoclonal antibody has to be subjected to biochemical and biophysical characterization for the desired specificity. It is also important to elucidate the MAb for the immunoglobulin class or sub-class, the epitope for which it is specific and the number of binding sites it possesses.

The stability of the cell lines and the MAbs are important. The cells (and MAbs) must be characterized for their ability to withstand freezing, and thawing. The desired cell lines are frozen in liquid nitrogen at several stages of cloning and culture

Clinical Uses of Monoclonal Antibodies

Since the most common methods for producing monoclonal antibodies use mouse cells, it is necessary to create **humanized monoclonal antibodies** for human clinical use. Mouse antibodies cannot be injected repeatedly into humans, because the immune system will recognize them as being foreign and will respond to them with neutralizing antibodies. This problem can be minimized by genetically engineering the antibody in the mouse B cell. The **variable regions** of the mouse light and heavy chain genes are ligated to human constant regions, and the chimeric gene is then transferred into a host cell. This allows production of a mAb that is mostly "human" with only the antigen-binding site being of mouse origin.

Humanized mAbs have been successfully used to treat cancer with minimal side effects. For example, the humanized monoclonal antibody drug **Herceptin** has been helpful for the treatment of some types of breast cancer. There have also been a few preliminary trials of humanized mAb for the treatment of infectious diseases, but none of these treatments are currently in use. In some cases, mAbs have proven too specific to treat infectious diseases, because they recognize some serovars of a pathogen but not others. Using a cocktail of multiple mAbs that target different strains of the pathogen can address this problem. However, the great cost associated with mAb production is another challenge that has prevented mAbs from becoming practical for use in treating microbial infections. One promising technology for inexpensive mAbs is the use of genetically engineered plants to produce antibodies (or **plantibodies**). This technology transforms plant cells into antibody factories rather than relying on tissue culture cells, which are expensive and technically demanding. In some cases, it may even be possible to deliver these antibodies by having patients eat the plants rather than by extracting and injecting the antibodies. For example, in 2013, a research group cloned antibody genes into plants that had the ability to neutralize an important toxin from bacteria that can cause severe gastrointestinal disease. Eating the plants could potentially deliver the antibodies directly to the toxin.

2.4 Antigen Antibody reaction as tools of research and diagnosis

A variety of assays have been developed which provide specific qualitative and quantitative measurement of Ag or Ab, both of which are often of considerable research and clinical relevance. Ab to an organism in the serum of a patient demonstrates infection by the organism. Ab with defined specificity is used to determine the presence of disease-associated antigens in a patient. As tools in molecular and cellular research, Abs permit localization and characterization of Ags.

The presence and concentration of a specific Ag or of an Ab to a specific Ag in solution can be determined by radioimmunoassays (RIA) or enzyme-linked immunosorbent assays (ELISA). Ag attached to a solid surface captures the Ab with which it reacts and is quantitated using a labeled second Ab reactive to the first. These assays permit measurement of a wide variety of Ags as well as the concentration and isotype of Abs specific for a given Ag, such as those reactive with an infectious organism.

Using a fluorescence microscope and Abs labeled with a fluorescent molecule, tissue sections can be examined for cells expressing particular Ags (e.g. those which are tumor associated). Direct or indirect immunofluorescence techniques permit qualitative and quantitative evaluation of several different cell-associated molecules at the same time. Flow cytometers rapidly analyze large numbers of cells in suspension, providing a molecular fingerprint of the cells. Fluorescence-activated cell sorters separate cell subpopulations for more detailed study.

Immunoblotting is used to assay for the presence of molecules in a mixture. Western blot analysis involves separating molecules by sodium dodecyl sulfate polyacrylamide gel electrophoresis (SDS-PAGE), transferring them to another matrix and detecting the molecule of interest using ELISA or RIA. This assay is often used to confirm the presence of Abs to infectious agents (e.g. HIV) in patient serum. Immunoblotting can also be used to analyze products of single cells (e.g. cytokines) and the nature of the producing cell.

Ab coupled to an insoluble matrix (e.g. agarose) specifically binds its Ag, which can then be eluted from the Ab yielding relatively pure Ag in one step. Similarly, Ag or protein A coupled to an insoluble

ELISA

The presence of Ab to a particular Ag in the serum of a patient can be determined using very sensitive radioimmunoassays (RIA) or enzyme-linked immunoabsorbent assays (ELISA). Such assays (Fig. 1) are of particular value in demonstrating Ab to Ags of infectious agents, e.g. virus, bacteria, etc. The presence of an Ab of a particular isotype can also be determined using a modification of these assays. The radioallergosorbent test (RAST) uses as detecting ligand a radiolabeled Ab to human IgE and permits the measurement of specific IgE Ab to an allergen. ELISA and RIA also provide very specific and sensitive measurement of toxins, drugs, hormones, pesticides, etc., not only in serum, but also in water, foods and other consumer products. Based on these procedures, assays for nearly any Ag or Ab can be readily developed.

Immunofluorescence and flow cytometry

Although it is possible to use ELISA and RIA to evaluate the presence of an Ag on a cell, this is usually more conveniently done using Abs to which a fluorescent marker has been covalently attached. Moreover, in most cases a mAb is used and thus is highly specific for a particular molecule and a particular epitope on that molecule. This type of assay can be done using an Ab to the Ag which is directly fluorescent labeled (direct immunofluorescence) or by first incubating the unlabeled Ab with the cells (e.g. a mouse mAb to human T cells) and then, after washing away unbound Ab, adding a

second fluorescent-labeled Ab that reacts with the first Ab (e.g. a goat Ab to mouse immunoglobulin).

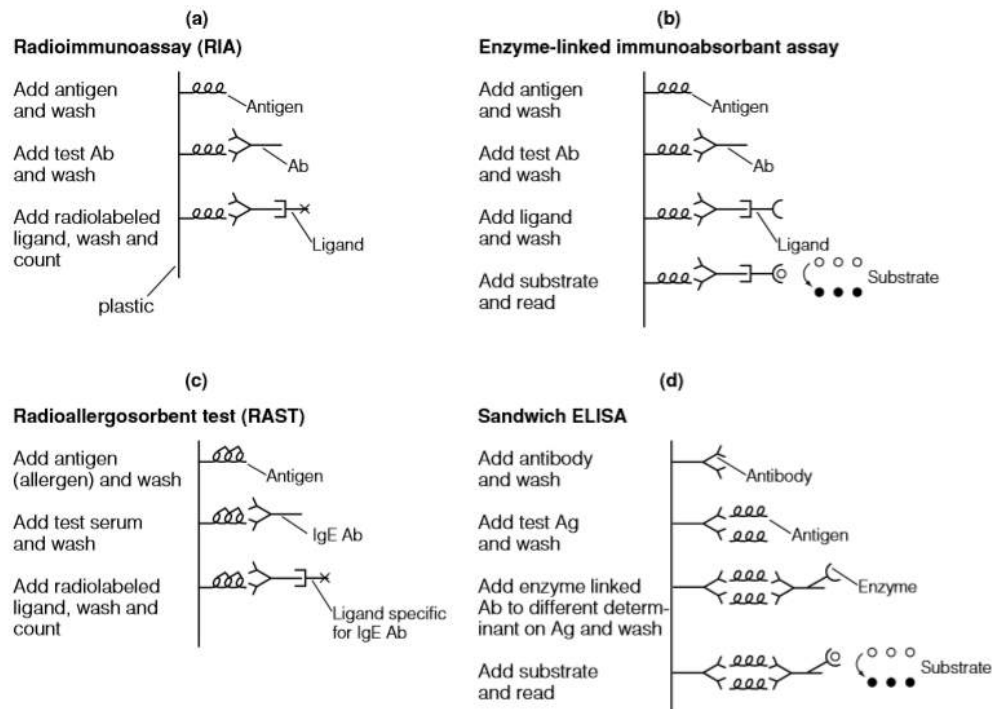

Fig. 1 (a) Radioimmunoassay (RIA). Antigen is incubated in a microtiter well and small quantities are adsorbed. Free antigen is washed away. Test antibody is added, which may bind to the Ag, and unbound Ab washed away. Ab remaining bound to the Ag is detected by a radiolabeled ligand (e.g. an Ab specific for the isotype of the test Ab, or staphylococcal protein A which binds to the Fc region of IgG). (b) Enzyme-linked immunosorbent assay (ELISA). This is similar to RIA except that the ligand (e.g. the Ab that binds the test Ag) is covalently coupled to an enzyme such as peroxidase. This ligand binds the test Ab and after free ligand is washed away the bound ligand is detected by the addition of substrate which is acted on by the enzyme to yield a colored and detectable end product. (c) Radioallergosorbent test (RAST). This measures Ag-specific IgE in an RIA where the ligand is a labeled anti-IgE Ab. (d) The sandwich assay is done as above except that Ab to an antigen is first adsorbed to a microtiter well and unbound Ab washed away. A potential source of Ag is added and what is not bound (captured) by the Ab is washed away. An enzyme-linked Ab to a different determinant on the Ag is then added, followed by washing. The presence of Ag is detected by the change in color of added substrate.

This indirect immunofluorescent assay (Fig. 2) has two advantages, it has higher sensitivity and requires labeling of only one Ab, the second Ab, because, in the example given, it can detect (react with) mouse Ab to other antigens. Fluorescent Abs to cell surface molecules (e.g. those which are tumor associated) are very useful in examining tissue sections for cells expressing the Ag. This assay is done by incubating the tissue section with the labeled Ab (for direct immunofluorescence) or unlabeled Ab, followed by labeled second Ab and then examining the tissue section using a fluorescent microscope. These microscopes irradiate the tissue with a wavelength of light that excites the fluorescent label on the Ab to emit light at a different wavelength. This emitted light can be directly visualized, photographed and even quantitated. Moreover, it is possible to analyze a tissue sample using several different Abs at the same time, as each Ab could be labeled with a different fluorescent molecule each of which emits light at a wavelength distinct from the others. It is also possible to look for intracellular molecules (e.g. Abs) by first permeabilizing the cells and then doing the staining and fluorescence microscopy. Thus, one can use this approach to develop a molecular fingerprint of the cells associated with a tissue. Although fluorescence microscopy can be, and is, applied to the analysis of single cell suspensions, another rather technologically sophisticated approach, flow cytometry, is most often used. This assay uses the same basic staining procedures as described for fluorescence microscopy, followed by automated quantitation of the amount of fluorescence associated with individual cells (Fig. 3). In particular, the suspension of stained cells is fed to the flow cytometer which

disperses the cells so they then pass single file through a focused laser beam which excites any fluorescent label associated with the cells. Those stained by the fluorescent Ab emit light that is detected and quantitated by optical sensors and the intensity of fluorescence is plotted in histogram form by a computer. This machine can analyze 1000 cells per second and provide quantitative data on the number of molecules of a particular kind on each cell. It can also analyze mixtures of cells and provide data on their size and granularity in addition to their expression of specific molecules. Some versions of this machine (fluorescence-activated cell sorter) are also able to separate out cells into microdroplets and sort those expressing a selected amount of a particular Ag into a separate tube for further analysis or culture.

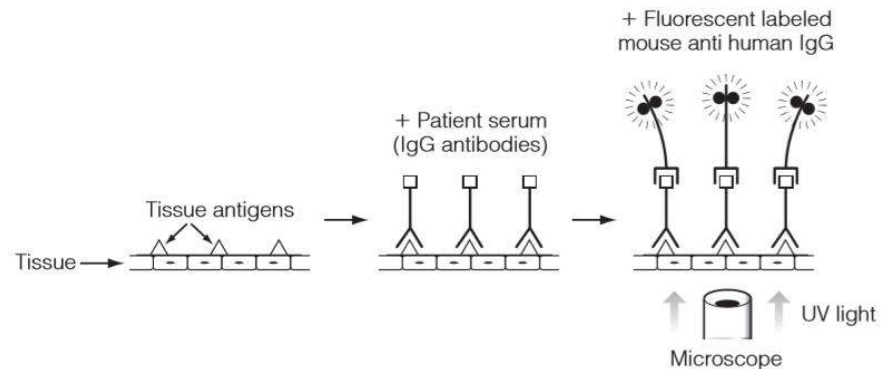

Fig. 2. Indirect immunofluorescence assay for autoantibodies. Patient serum is added to tissue sections and the autoantibodies bind to particular autoantigen(s). After washing, fluorescent antibodies to human IgG are added and viewed under a fluorescence microscope. A green color shows where the human antibodies have bound to the tissue autoantigens.

Immunoblotting

It is possible to combine various separation and detection procedures for identification and analysis of Ags and for evaluating the expression of molecules by single cells. Western blot analysis involves separating Ags by polyacrylamide gel electrophoresis (PAGE) in the presence of sodium dodecyl sulfate (SDS) which results in separation of molecules on the basis of size. These molecules are then transferred to another matrix (e.g. nitrocellulose) to form a pattern on the matrix identical to that on the gel. Enzyme-linked Ab to the molecule of interest is then added, the unbound Ab washed off and substrate added (see ELISA) for visualization. This assay permits specific identification of proteins in a mixture and is also often used to confirm the presence of Abs to certain infectious agents (e.g. HIV) in the serum of patients. Immunoblotting can also be used to assay for the presence of molecules in a mixture as described for the sandwich ELISA. This has now been extended for analysis of products of single cells. For example, to assay for production of a cytokine, Ab to the cytokine is coated onto the nitrocellulose 'floor' of a special culture well (see sandwich ELISA), the unbound Ab is washed off, and cells are then plated on top of this Ab. After incubation, an enzyme-linked Ab to a different determinant on the cytokine is added, followed by washing and substrate addition. Wherever a cell produced the cytokine, it will be captured by the first Ab and will then be detected by the second Ab and its conversion of substrate, forming a colored spot on the nitrocellulose (hence the name ELISPOT assay). The nature of the cell producing the cytokine can also be determined by flow cytometry after staining the cells with a fluorescent-labeled cell-type-specific Ab (e.g. anti-CD4 for T helper cells) and an anti-cytokine Ab labeled with a different fluorochrome.

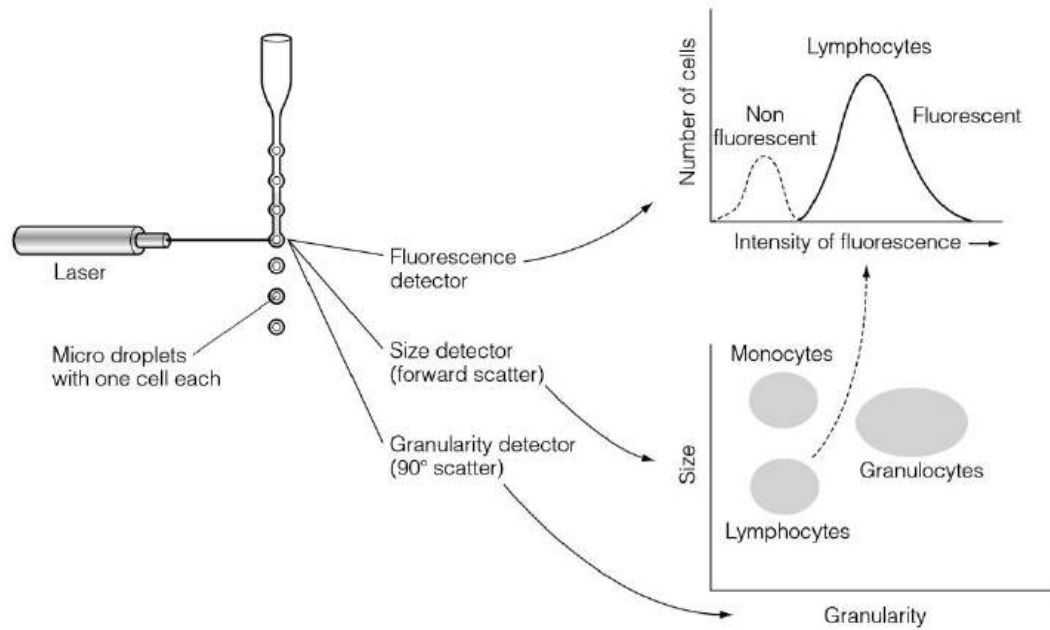

Fig. 3. Flow cytometry. After labeling with fluorescent antibody, cells are passed one at a time through a laser beam. Photodetectors measure the amount of fluorescence which is plotted as a histogram showing the proportion of non-fluorescent (unstained) and fluorescent (stained) cells. Other detectors simultaneously measure scattered laser light, which is used to generate a 'dot blot' in which lymphocytes, monocytes and granulocytes can be discriminated.

Affinity purification of Ag and Ab

The specificity of Abs is not only important to the development of many research and diagnostic assays, but can, in some instances, be used to purify, or be purified by, interaction with Ag. This is because Abs do not form covalent bonds when they combine with Ag. Ab coupled to an insoluble matrix (e.g. agarose) specifically binds its Ag, removing it from a mixture of other molecules. After washing to remove all unbound molecules, the Ag can be eluted at low pH and/or at high ionic strength, which breaks the reversible bonds holding it to the Ab. As this can usually be performed without damaging the Ag or Ab, it is possible to obtain relatively pure Ag in one step. Similarly, Ag coupled to an insoluble matrix permits purification of Ab from media or serum. Ab can also be purified based on its binding by proteins (e.g. protein A) isolated from some strains of *Staphylococcus aureus*. Protein A coupled to agarose binds IgG Abs which can be eluted by decreasing the pH and/or by increasing the ionic strength of the eluting buffer, again without damaging the Ab. Using similar techniques, cell subpopulations with characteristic cell surface molecules (e.g. immunoglobulin on B cells) can also be isolated (positive selection) or removed (negative selection) from a mixture of cells.

6th SEMESTER

ZOO616DA: ZOOLOGY – IMMUNOLOGY

Unit 3rd

3.1 Structure and function of MHC

The term histocompatible refers to the individuals who the same tissues i.e. identical twins. This term is used to determine how identical two unrelated individuals are. In case of two histocompatible individuals, a tissue or organ from a donor (the person giving the organ or tissue) that will not be rejected by the recipient (the patient in whom the tissue or organ is transplanted).

Thus, histocompatibility is the property of having the same or mostly the same alleles of a set of genes called the 'major histocompatibility complex'. These genes are expressed in most tissues as antigens to which the immune system makes antibodies.

Major histocompatibility complex (MHC) is a tightly linked cluster of genes present on chromosome 6 in humans (and chromosome 17 in mice) which encodes the MHC proteins. The MHC proteins are present on plasma membrane of almost all human tissue/cells. The MHC proteins participate in intercellular recognition and antigen presentation to T lymphocytes.

Generally, a group of linked MHC genes is inherited as a unit from parents. These linked groups are called haplotypes. MHC genes are polymorphic {i.e. there are a large number of alleles for each gene). Also they are polygenic (i.e. there are a number of different MHC genes). Human MHC molecules are also called human leucocyte antigens (HLA).

In the mid 1930s Peter Gorer (England) established the concept of rejection of foreign tissue due to an immune response to cell surface molecules. This gave the birth to the study of histocompatibility antigens. He identified four types of genes (I to IV) which encode blood cell antigens.

During 1950 George Snell (U.S.A.) pioneered the concept that antigens encoded by the genes took part in the rejection of transplanted tumours. He called these genes as histocompatibility genes. For this work Snell was awarded the Nobel Prize in 1980.

Classes of MHC Molecules:

The MHC genes are organized into three classes I, II and III which express three classes of molecules Classes I, II and III, respectively (Table 22.5). Classes I MHC genes consists of A, B and C gene loci. They secrete glycoproteins which are referred to as Class I MHC molecule. Glycoproteins are expressed on the surface of about all nucleated cells. Class I MHC molecules present the peptide antigens to T_C cells.

Table 22.5 : Organisation of major histocompatibility complex (MHC) HLA genes in human in chromosome 6.

Class	Class II			Class III	Class I		
Regions	DP	DQ	DR	C ₄ , C ₂ and B2F	B	C	A
Gene	DP	DQ	DR	C Proteins	TNF-α	HLA-B	HLA-C
Product	αβ	αβ	αβ		TNF-β		

The human Class I MHC gene spans about 2,000 kb (about 20 genes) at the telomeric end of the HLA complex, whereas the Class II MHC genes (about 1,000 kb) are located at the centromeric end of HLA. Class III genes (flanked by about 10,000 kb long) located between the two genes.

The DP, DQ and DR region of Class II MHC genes in humans encode the Class II MHC molecules called glycoproteins. They are expressed on antigen presenting cells such as macrophages, dendric cells and B cells, and present the processed antigenic peptides to T_H cells. Class II molecules have specialised function in the immune response.

Both Class I and Class II molecules have common structural features. They have role in antigen processing. In addition, the Class III MHC gene is flanked by Class I and Class II regions and encodes molecules critical to immune function. Class III MHC molecules consist of complement components C4, C2, BF, inflammatory cytokines, including tumour necrosis factor (TNF) and heat shock proteins.

Structure of MHC Molecules:

The Class I molecule is a trans-membrane glycoprotein consisting of two chains: a-chain or heavy chain (of 42 KD molecular weight) non-covalently associated with a light chain called β_2 -micro-globulin (molecular weight 12 KD).

The α -chain is organized into three extracellular domains (α_1 , α_2 , α_3) and a 'trans-membrane segment' (hydrophobic) followed by a short stretch of hydrophilic 'cytoplasmic tail' (Fig. 22.20A). These are encoded by A, B and C regions of HLA complex and expressed on the surface of plasma membrane of almost all cells except erythrocytes.

β_2 -micro-globulin molecule is expressed by different chromosomes. Association of the α -chain with β_2 -micro-globulin is must for expression of Class I molecules on cell membrane. The α_1 and α_2 form the antigenic-binding cleft located on top of surfaces of molecule.

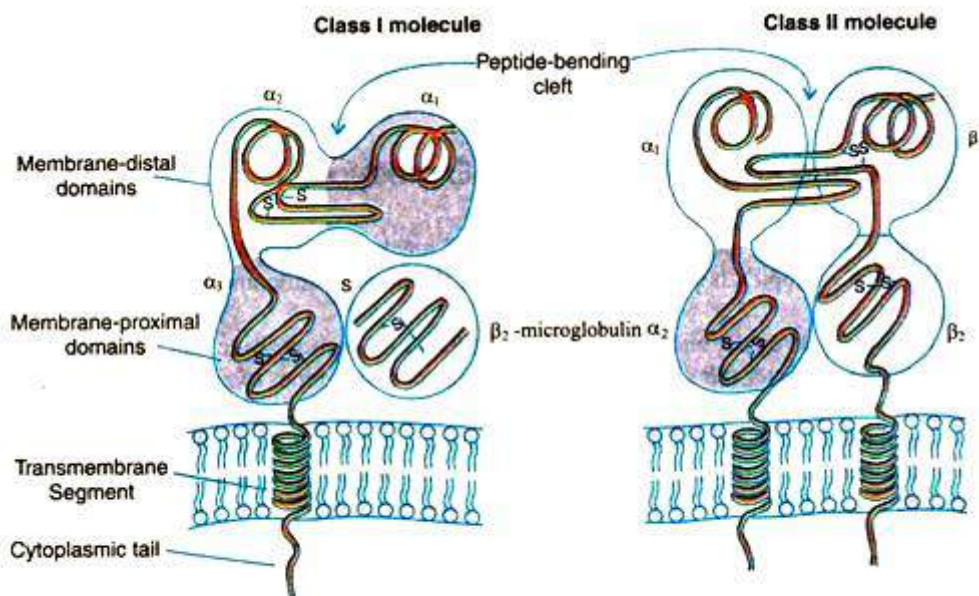

Fig. 22.20 : Structure of MHC molecules; A, Class I molecule; B-Class II molecule.

Class II MHC molecules are also trans-membrane glycoprotein encoded by separate MHC genes. They contain two different α and β chains of 33 and 28 KD, respectively. These two chains are associated non-covalently (Fig. 22.20B)

Further, both chains fold to give two domains (β_1 and β_2 domains in other domain), one is membrane proximal domain and the second is membrane-distal domain. Like Class I MHC molecules, the class II molecules also contain trans-segment and a cytoplasmic anchor segment. Each chain of Class II molecule contains two external domains (α_1 and α_2 in one chain) and β_1 and β_2 domains in other chain.

Function of MHC Molecules:

MHC provides both cell mediated and humoral immune responses, while antibodies react only – with antigens, and most of the T cells recognise antigen only when it gets combined with an MHC molecule. Hence, MHC molecules act as antigen-presenting structure.

The MHC partly determines the response of an individual to antigens of infectious microorganisms. Therefore, it is implicated in susceptibility to disease and in the development of autoimmunity. Recently, it has been explained that the natural killer cells express receptors for MHC Class I antigens. The receptor-MHC interaction result in inhibition/activation.

Both Class I and Class II MHC molecules present the processed endogenous antigen to CD8 T cells. Class II molecules present the processed exogenous antigen to CD4 T cells. Class I molecules identifies mostly all the cells of the body as 'self'. Also they induce the production of antibodies which introduced into host with different Class I molecules. This is the basis for MHC typing when a patient is to undergo for antigen transplantation.

Class II molecules comprise of the D group of MHC. They stimulate the production of antibodies. But they are required for T cell communication with macrophage and B cells. Part of T cells receptor recognises Class II molecules on the adjacent cell before cytokine secretion by T cells. This is necessary for immune response.

Both Class I and Class II molecules recognise the microorganisms. They are also involved in the susceptibility of an individual to a specific non-infectious diseases e.g. multiple sclerosis, acute glomerulonephritis, tuberculoid leprosy, paralytic poliomyelitis, etc. The Class III molecules (e.g. C_2 , C_{4a} and C_{4b}) participate in the classical pathway and factor B in the alternate pathway of the immune responses.

Gene Regulation of MHC Expression:

Regulation of MHC genes has not been studied much. Understanding of complete genomic map of the MHC complex hopefully will accelerate the identification and coding, and regulatory sequences. Transcriptional regulation of the MHC is mediated by both positive and negative elements e.g. MHC II trans-activator (CIITA) and transcription factor (RFX) binds to promoter region of Class II MHC gene.

Any error in these transcription factor causes a type of disease in lymphocytes. Expression of MHC molecules is also regulated by many kinds of cytokines. Interferons and tumour necrosis factor increases the expression of Class I molecules on cells. Interferon-gamma induces the expression of CIITA.

Expression of MHC decreases after infection by certain viruses e.g. hepatitis B virus, and adenovirus 12, cytomegalovirus, etc. Adenovirus 12 causes a decrease in transcription of the transporter genes (TAP1 and TAP2). When these genes are blocked, class I molecules fail to assemble with β_2 -microglobulin.

Decreased level of Class I molecules promotes viral infection. Expression of Class II molecules by B cells is down-regulated by INF-gamma. Corticosteroids and prostaglandins decrease the expression of Class II molecules

3.2 Exogenous and Endogenous pathways of antigen processing and presentation

Antigens are [macromolecules](#) that elicit an immune response in the body. Antigens can be

- [proteins](#)
- [polysaccharides](#)
- conjugates of lipids with
 - proteins ([lipoproteins](#)) and
 - polysaccharides (glycolipids).

Most of this page will describe how **protein** antigens are presented to the immune system.

The presentation of lipid and polysaccharide antigens will be mentioned at the end.

It will be helpful to distinguish between

- antigens that enter the body from the environment; these would include
 - inhaled macromolecules (e.g., proteins on cat hairs that can trigger an attack of [asthma](#) in susceptible people)
 - ingested macromolecules (e.g., shellfish proteins that trigger an [allergic response](#) in susceptible people)
 - molecules that are introduced beneath the skin (e.g., on a splinter or in an injected [vaccine](#))
- antigens that are generated within the cells of the body; these would include
 - proteins encoded by the genes of viruses that have infected a cell
 - aberrant proteins that are encoded by mutant genes; such as mutated genes in cancer cells

In all cases, however, the **initial immune response** to any antigen absolutely requires that the antigen be recognized by a **T lymphocyte** ("[T cell](#)"). The truth of this rule is clearly demonstrated in **AIDS**: the infections (viral or fungal or bacterial) that so often claim the life of AIDS patients do so when the patient has lost virtually all of his or her [CD4⁺](#) T cells.

The two categories of antigens are processed and presented to T cells by quite different mechanisms.

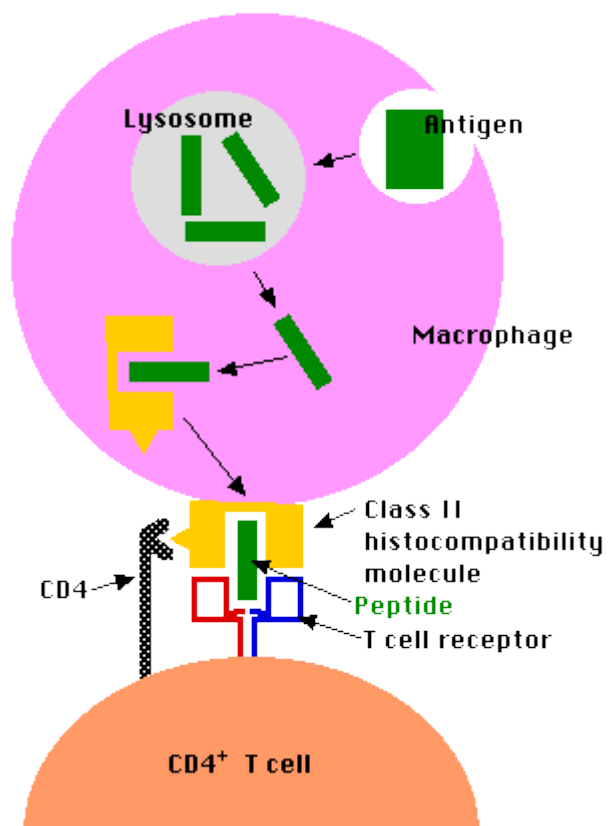

First Group: Exogenous antigens

Exogenous antigens (inhaled, ingested, or injected) are taken up by **antigen-presenting cells (APCs)**. These include:

- **phagocytic cells** like [dendritic cells](#) and [macrophages](#);
- **B lymphocytes** ("[B cells](#)"); which are responsible for producing [antibodies](#) against the antigen.

Antigen-presenting cells

- engulf the antigen by [endocytosis](#).
- The endosome fuses with a [lysosome](#) where the antigen is
- degraded into fragments (e.g. short peptides).
- These antigenic peptides are then displayed at the surface of the cell nestled within a
- [class II histocompatibility molecule](#).
- Here they may be recognized by **CD4⁺ T cells**.

(Dendritic cells and macrophages can also present **intact** antigen directly to [B cells](#). In this case, the engulfed antigen is not degraded in lysosomes but is returned to the cell surface for presentation to B cells bearing [BCRs](#) of the appropriate specificity.)

Second Group: Endogenous antigens

Antigens that are generated within a cell (e.g., viral proteins in **any** infected cell) are

- degraded into fragments (e.g., peptides) within the cell and displayed at the surface of the cell nestled within a
- [class I histocompatibility molecule](#).
- Here they may be recognized by **CD8⁺ T cells**.
- Most CD8⁺ T cells are cytotoxic.
- They have the machinery to destroy the infected cell (often before it is able to release a fresh crop of viruses to spread the infection).

Now for more details.

The Class I Pathway

Class I histocompatibility molecules are [transmembrane proteins](#) expressed at the cell surface. Like all transmembrane proteins, they are synthesized by ribosomes on the rough endoplasmic reticulum (RER) and assembled within its [lumen](#).

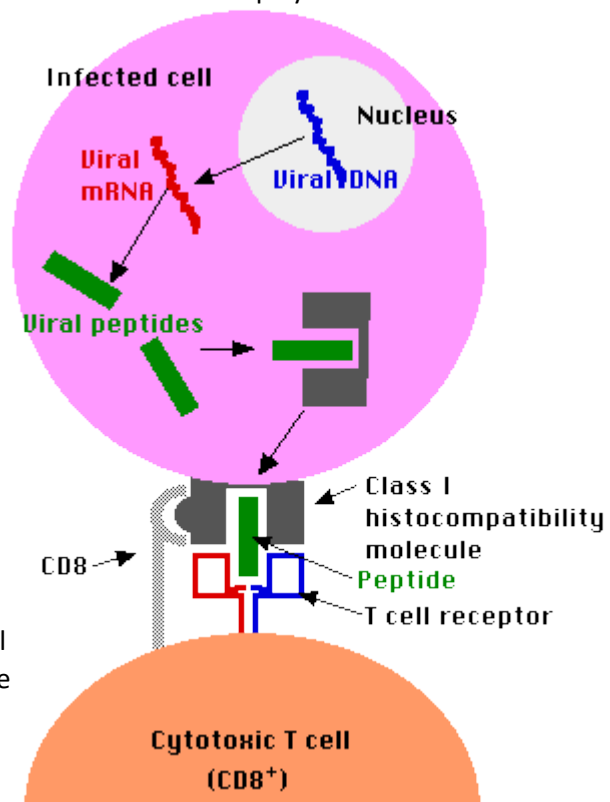

There are three subunits in each class I histocompatibility molecule:

- the transmembrane polypeptide (called the "heavy chain")
- the antigenic peptide
- beta-2 microglobulin

All of these must be present within the lumen of the [endoplasmic reticulum](#) if they are to assemble correctly and move through the [Golgi apparatus](#) to the cell surface.

The Problem: proteins encoded by the genes of an infecting virus are synthesized in the **cytosol**. How to get them into the endoplasmic reticulum?

The Solution: **TAP** (= transporter associated with antigen processing).

- Viral proteins in the cytosol are degraded by [proteasomes](#) into viral peptides.
- The peptides are picked up by TAP proteins embedded in the membrane of the endoplasmic reticulum.
- Using the energy of ATP, the peptides are pumped into the [lumen](#) of the endoplasmic reticulum where they assemble with
- the transmembrane polypeptide and beta-2 microglobulin.
- This trimolecular complex then moves through the Golgi apparatus and is inserted in the plasma membrane.
- The complex can be bound by a **T cell** with
 - a receptor (**TCR**) able to bind the peptide and flanking portions of the histocompatibility molecule (the hot dog in the bun) and
 - **CD8** molecules that bind the **CD8 receptor** (shown above as a gray hemisphere) on the histocompatibility molecule.

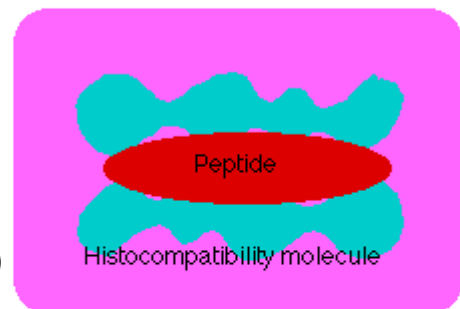

"Hot Dog in a Bun"

Here an antigenic peptide is nestled between the alpha helices (blue) exposed at the outer surface of a histocompatibility molecule

The Class II Pathway

Class II histocompatibility molecules consist of

- two transmembrane polypeptides and
- a third molecule nestled in the groove they form.

All three components of this complex must be present in the **endoplasmic reticulum** for proper assembly.

But antigenic peptides are not transported to the endoplasmic reticulum, so a protein called the **invariant chain** ("Ii") temporarily occupies the groove.

The steps:

- The two chains of the class II molecule are inserted into the membrane of the endoplasmic reticulum.

- They bind (in their groove) one molecule of invariant chain.
- This trimolecular complex is transported through the Golgi apparatus and into vesicles called [lysosomes](#).

Meanwhile,

- Foreign antigenic material is engulfed by [endocytosis](#) forming **endosomes**.
- These also fuse with lysosomes.

Then,

- The antigen is digested into fragments.
- The invariant (Ii) chain is digested.
- This frees the groove for occupancy by the antigenic fragment.
- The vesicles move to the plasma membrane and the complex is displayed at the cell surface.
- The complex can be bound by a **T cell** with
 - a receptor (**TCR**) able to bind the peptide and flanking portions of the histocompatibility molecule (the hot dog in the bun) and
 - **CD4** molecules that bind the **CD4 receptor** ([shown above](#) as a yellow triangle) found on all class II histocompatibility molecules.

Interconnections Between the Class I and Class II Pathways

Cross-Presentation: Transferring Exogenous Antigens to the Class I Pathway

Cross-presentation is the transferring of extracellular antigens like bacteria, some tumor antigens, and antigens in cells infected by viruses into the class I pathway for stimulation of CD8⁺[cytotoxic T cells](#) (CTL). Only certain "professional" [antigen-presenting cells](#) (APCs) like [dendritic cells](#) can do this; that is, use the class I as well as the class II pathways of antigen presentation.

Cross-presentation following infection by viruses is important because:

- Most viruses infect cells other than APCs (e.g., liver cells, epithelial cells of the lung) (and, of course, are intracellular in these).
- While viral antigens displayed on the surface of any infected cell can serve as **targets** for [cytotoxic T cells](#) (CTLs),
- the lack of any [costimulatory molecules](#) on the cell surface makes them **poor stimulants** for the development of clones of CTLs in the first place.

However, when an infected cell dies, it can be **engulfed** by a professional APC, and the antigens within it can enter the class I pathway. One mechanism:

- The dead cell is engulfed by endocytosis.
- The endosome that forms fuses with a lysosome and degradation of the dead cell begins.
- Antigens pass into the cytosol and are degraded in [proteasomes](#).

- The peptides formed are then picked up by TAP and, as [described above](#),
- inserted into class I MHC molecules and
- displayed at the cell surface — along with the costimulatory molecules needed to start a vigorous clonal expansion of CD8⁺ cytotoxic T cells.

Diverting Antigens from the Class I to the Class II Pathway

Autophagy provides a mechanism by which cells can transfer **endogenous** (intracellular) antigens into the class II pathway, for example

- self-proteins so as to be able to [delete](#) CD4⁺ T cells with receptors capable of attacking them and thus potentially capable of causing autoimmunity.
- proteins synthesized by an infecting virus. In this way viral infection can generate **CD4⁺ T cells** as well as cytotoxic T cells (CD8⁺).

B Lymphocytes: A Special Case

B lymphocytes are both antigen-receiving and antigen-presenting cells. They bind intact antigens (e.g., virus particles, proteins) with their B cell receptor (BCR). They can come in contact with these antigens by

- encountering them in the surrounding [lymph](#) or
- by being presented them by macrophages or [dendritic cells](#).

B lymphocytes process antigen by the class II pathway for presentation to T cells.

The process:

- B cells engulf antigen by [receptor-mediated endocytosis](#)
- The B cell receptors for antigen (BCRs) are antibodies anchored in the plasma membrane.
- The [affinity](#) of these for an epitope on an antigen may be so high that the B cell can bind and internalize the antigen when it is present in body fluids in concentrations thousands of times smaller than a macrophage would need.
- The remaining steps of antigen processing occur by the same class II pathway described above for macrophages producing
- fragments of antigen displayed at the cell surface nestled in the groove of class II histocompatibility molecules.

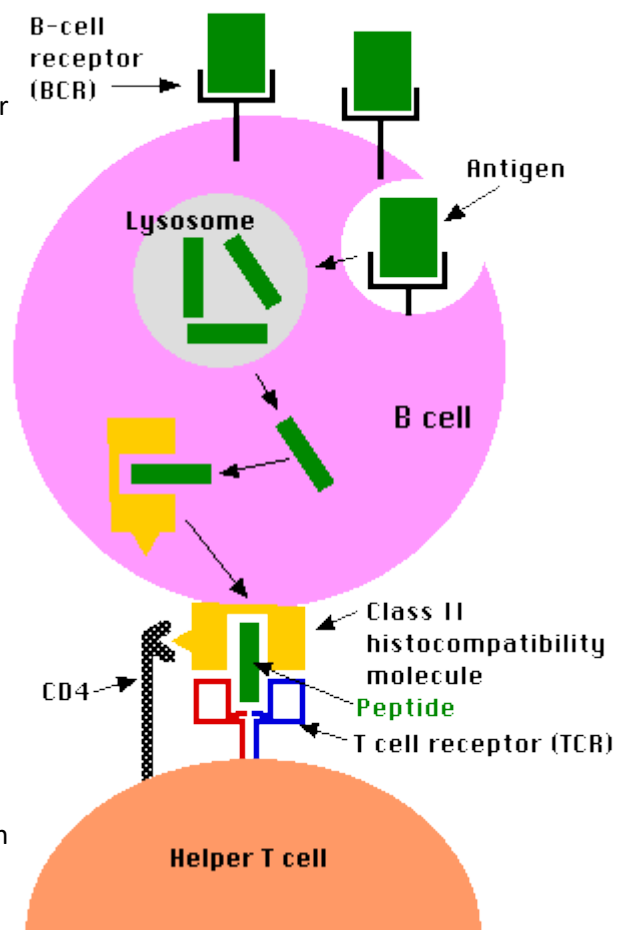

- A CD4⁺ T cell that recognizes the displayed antigen is stimulated to release [lymphokines](#).
- These, in turn, stimulate the B cell to enter the [cell cycle](#).
- Because of the part they play in stimulating B cells, these CD4⁺ T cells are called [Helper T cells](#) ("Th").
- The B cell grows into a [clone of cells](#) (called **plasma cells**)
- These synthesize receptors (**BCRs**) with the **identical binding site** for the epitope but without the transmembrane tail.
- These **antibodies** are secreted into the surroundings.

Lipid and Polysaccharide Antigens

Lipid Antigens

- Lipid antigens are presented to T cells by cell-surface molecules designated **CD1** ("[cluster of differentiation](#)" 1).
- Antigen-presenting cells express several different forms of CD1 at their surface. Each is probably specialized to bind a particular type of lipid antigen (e.g. lipopeptide vs glycolipid).
- The exposed surface of CD1 molecules forms an antigen-binding groove much like that of MHC molecules except that
- the amino acids in the groove are more hydrophobic than those in MHC molecules.
- Like protein antigens, lipid antigens are also presented as fragments, i.e., as a "[hot dog in a bun](#)".

Polysaccharide Antigens

Some bacterial polysaccharides ingested by APCs

- can be degraded in their lysosomes
- and presented to T cells by MHC class II molecules.

[Nitric oxide](#) (NO) appears to be essential for this process.

Costimulation

The binding of a T cell to an antigen-presenting cell (APC) is **by itself** not enough to activate the T cell and turn it into an effector cell: one able to, for examples,

- kill the APC (CD8⁺ cytotoxic T lymphocytes [CTLs])
- carry out [cell-mediated immune reactions](#) (CD4⁺ [Th1 cells](#))
- provide help to B cells (CD4⁺ [Th2 cells](#))

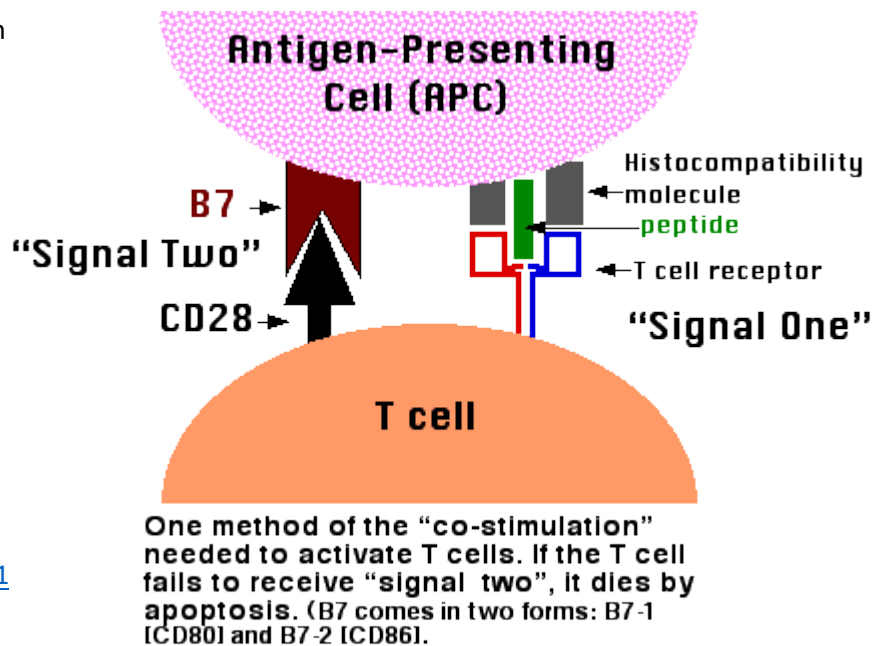

In order to become activated, the T cell must not only bind to the epitope (MHC-peptide) with its TCR but also receive a **second signal** from the APC. The receipt of this second signal is called **costimulation**. Among the most important of these costimulators are molecules on the APC designated **B7** and their ligand on the T cell designated **CD28**. The binding of CD28 to B7 provides the second signal needed to activate the T cell.

Although T cells may encounter self antigens in body tissues, they will not respond unless they receive a second signal. In fact, binding of their TCR ("signal one") without "signal two" causes them to self-destruct by [apoptosis](#). Most of the time, the cells presenting the body's own antigens either

- fail to provide signal two or
- transmit an as-yet-unidentified second signal that turns the T cell into a [regulatory T cell](#) (**Treg**) that suppresses immune responses.

3.3 Basic properties and functions of cytokines

Cytokines are a broad and loose category of small proteins (~5–20 kDa) that are important in cell signaling. Their release has an effect on the behavior of cells around them. It can be said that cytokines are involved in autocrine signaling, paracrine signaling and endocrine signaling as immunomodulating agents. Their definite distinction from hormones is still part of ongoing research. Cytokines may include chemokines, interferons, interleukins, lymphokines, and tumour necrosis factors but generally not hormones or growth factors.

1. Cytokines are a group of low-molecular-weight regulatory proteins secreted by WBC and other cells in the body.
2. Cytokine secretion is very specific and self-limited event as because they are not usually stored as performed molecules. Cytokine synthesis is initiated by new gene transcription as a consequence of cellular activation. Once synthesized, cytokines are rapidly secreted, resulting in a burst of release when needed.

3. After secretion, cytokines (almost 60 different types of cytokines) regulate immune and inflammatory reactions

4. Cytokines bind to specific receptors on the membrane of target cells, triggering signal- transduction pathways that ultimately alter gene expression in the target cells . The nature of the target cell for a particular cytokine is determined by the presence of specific membrane receptors. Cytokines are so specific due to their high affinity for which Pico molar concentrations of cytokines can mediate a biological effect.

5. Cytokine actions may be local or systemic.

(i) Most of the cytokines act close to where they are produced, A particular cytokine when binds to receptors on the membrane of the same cell from where it has been secreted is called autocrine action.

(ii) When secreted cytokines bind to receptors on a target cell in close proximity to the producer cells, it is called paracrine action.

(iii) In most of the cases, cytokines act on cells that are in contact with the cytokine producers but when cytokines are pro-duced in large amounts, it may enter the circulation and act at a distance from the site of production. This is called endocrine action.

6. Cytokines often influence the synthesis and actions of other cytokines and different immune cells. The ability of one cytokine to stimulate production of others, leads to cas-cade in which a second or third cytokine may mediate the biological effects of the first. Cytokines regulate the intensity and duration of the immune response by stimulating or inhibiting the activation, proliferation and differentiation of various cells.

7. The cytokines secreted by a single lympho-cyte following antigen-specific activation can influence the activity of various cells involved in the immune response. For example, cytokines produced by activated TH cells (T-helper cells) can influence the activity of B-cells, Tc cells, natural killer cells (NK cells), macrophages, granulocytes and haemato-poietic stem cells. This means that it activates an entire network of interacting cells.

Cytokines are small cell-signaling protein molecules secreted by numerous cells and used extensively in intercellular communication. Cytokines can be classified as proteins, peptides, or glycoproteins. They provide the signaling pathways that orchestrate the complex immune responses of the human body. Cytokines are similar to hormones, which are also chemical messengers, but hormones have considerably more variation in molecular structure and are involved more in tissue signaling than cellular signaling.

Each cytokine has a matching cell-surface receptor. Subsequent cascades of intracellular signalling then alter cell functions. This may include the upregulation (increased expression) and/or downregulation (decreased expression) of several genes and their transcription factors resulting in the production of other cytokines, an increase in the number of surface receptors for other molecules, or the suppression of their own effects by feedback inhibition.

Interleukins

Interleukins are a class of cytokines primarily expressed by leukocytes. They are glycoproteins involved in the signaling of many types of immune system functions. There are 17 different families of

interleukins. Some of the more important ones include inflammatory mediators such as IL-1, IL-4, and IL-6, the potent anti-inflammatory IL-10, and other interleukins involved with T and B cell signaling following antigen presentation. Many interleukins are also considered lymphokines, interleukins released by helper T cells to organize immune responses.

Interferons

Interferons are protein cytokines that have antiviral functions. They can activate macrophages and natural killer (NK) cells to attack and lyse virus-infected cells. One common interferon is IFN-gamma, a pyrogen involved in inflammatory response and macrophage and NK cell activation. IFN-gamma is produced by T cells (both CD4 and CD8) and NK cells.

Chemokines

Chemokines are protein cytokines that are mainly involved in facilitating chemotaxis (chemical-stimulated movement) in immune cells. Leukocytes travel along chemotactic gradients that guide them to sites of injury, infection, or inflammation. By definition, inflammatory mediators in other classes of cytokines are also considered chemokines. This category also includes cytokines that are only involved in leukocyte migration, such as CCL2 which causes monocyte chemotaxis and stimulates its differentiation into macrophages inside of tissues.

Tumor Necrosis Factor

Tumor necrosis factor (TNF) are cytokines that induce apoptosis in abnormal cells such as tumor cells. It is a protein released by NK cells, macrophages, and helper T cells, typically in systemic immune responses. TNF-alpha is the most notable example. This long-lasting inflammatory mediator and pyrogen can cause fever and inflammation for up to 24 hours. It also stimulates acute phase reaction in the liver, a component of systemic immune system activation where the liver makes proteins involved in immune system response such as complement proteins. TNF-alpha is released in very high amounts in response to lipopolysaccharide (infection with gram negative bacteria), which facilitates much of the self-destructive immune response in septic shock. In these cases, TNF-alpha can cause organ failure from tissue hypoperfusion, caused by damage and blood clotting from an overactive immune response.

On the basis of principal biologic actions; cytokines are grouped under three basic categories:

(i) Mediators and regulators of innate immunity:

These are produced mainly by mononuclear phagocytes in response to infectious agents: Pathogen-associated molecular patterns; like bacterial lipopolysaccharides (LPS) and viral double stranded RNA (dsRNA), also bind to Toll like receptors (TLRs) on the cell surface or in endosomes of macrophages and stimulate the synthesis of some important cytokines of innate of Innate immunity. They act on endothelial cells and leukocytes.

(ii) Mediators and regulators of adaptive immunity:

These are produced mainly by T-lymphocytes in response to specific recognition of foreign antigens. Some T-cell cytokines regulate the growth and differentiation of various lymphocyte populations and are related with T cell-dependent immune responses. These cytokines also regulate and activate mononuclear phagocytes, neutrophils and eosinophils.

(iii) Stimulators of haematopoiesis:

These are produced by bone marrow stromal cells, leukocytes and other cells, and stimulate the growth and differentiation of immature leukocytes. Therefore, in general, the cytokines of innate and adaptive immunity are produced by different cell populations and act on different target cells.

3.4 Complement system Components and pathways

The complement system is a part of the immune system that enhances (complements) the ability of antibodies and phagocytic cells to clear microbes and damaged cells from an organism, promotes inflammation, and attacks the pathogen's cell membrane. It is part of the innate immune system, which is not adaptable and does not change over the course of an individual's lifetime. The complement system can, however, be recruited and brought into action by antibodies generated by the adaptive immune system.

The complement system consists of a number of small proteins found in the blood, synthesized by the liver, and circulate as inactive precursors. When stimulated by one of several triggers, proteases in the system cleave specific proteins to release cytokines and initiate an amplifying cascade of further cleavages. The end result of this complement activation or complement fixation cascade is stimulation of phagocytes to clear foreign and damaged material, inflammation to attract additional phagocytes, and activation of the cell-killing membrane attack complex. Over 30 proteins and protein fragments make up the complement system, including serum proteins, and cell membrane receptors.

Most of the proteins and glycoproteins that constitute the complement system are synthesized by hepatocytes. But significant amounts are also produced by tissue macrophages, blood monocytes, and epithelial cells of the genitourinary system and gastrointestinal tract. The three pathways of activation all generate homologous variants of the protease C3-convertase. The classical complement pathway typically requires antigen-antibody complexes for activation (specific immune response), whereas the alternative pathway can be activated by spontaneous complement component 3 (C3) hydrolysis, foreign material, pathogens, or damaged cells. The mannose-binding lectin pathway can be activated by C3 hydrolysis or antigens without the presence of antibodies (non-specific immune response). In all three pathways, C3-convertase cleaves and activates component C3, creating C3a and C3b, and causes a cascade of further cleavage and activation events. C3b binds to the surface of pathogens, leading to greater internalization by phagocytic cells by opsonization.

In the alternative pathway, C3b binds to Factor B. Factor D releases Factor Ba from Factor B bound to C3b. The complex of C3b(2)Bb is a protease which cleaves C5 into C5b and C5a. C5 convertase is also formed by the classical pathway when C3b binds C4b and C2b. C5a is an important chemotactic protein, helping recruit inflammatory cells. C3a is the precursor of an important cytokine (adipokine) named ASP (although this is not universally accepted and is usually rapidly cleaved by carboxypeptidase B. Both C3a and C5a have anaphylatoxin activity, directly triggering degranulation of mast cells as well as increasing vascular permeability and smooth muscle contraction.[6] C5b initiates the membrane attack pathway, which results in the membrane attack complex (MAC), consisting of C5b, C6, C7, C8, and polymeric C9.[7] MAC is the cytolytic endproduct of the complement cascade; it forms a transmembrane channel, which causes osmotic lysis of the target cell. Kupffer cells and other macrophage cell types help clear complement-coated pathogens

Classical pathway

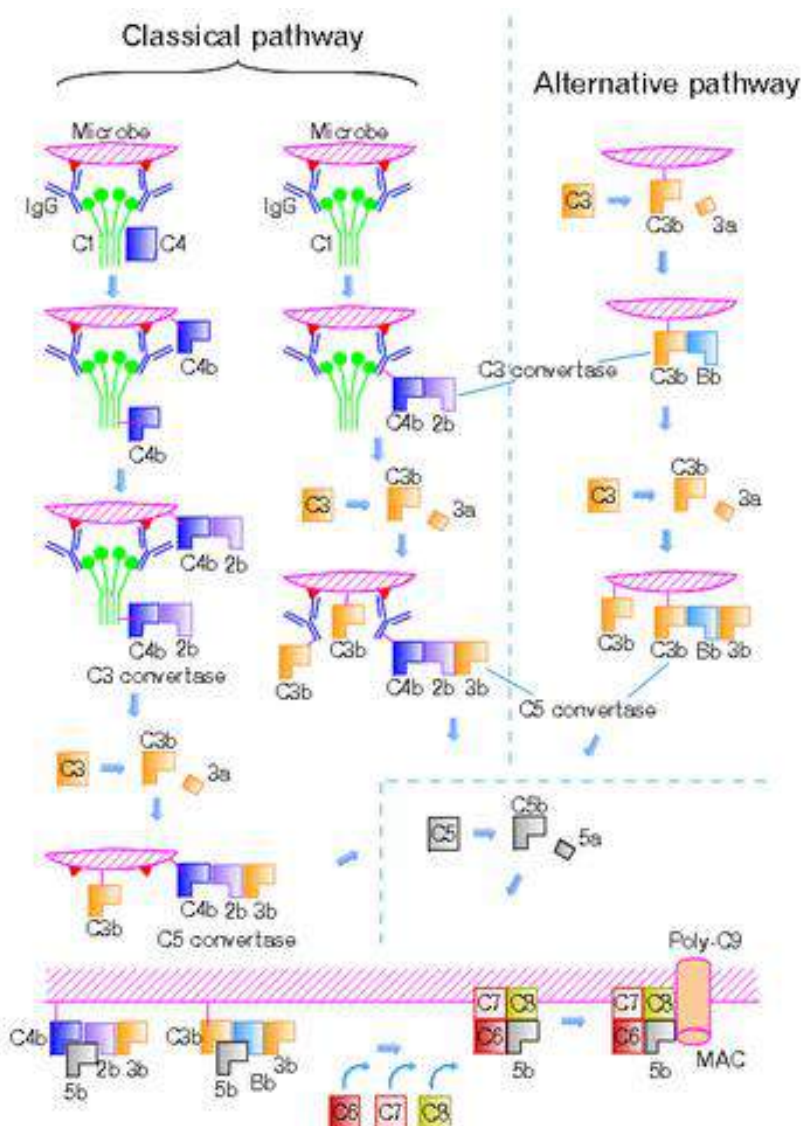

The classical and alternative complement pathways

The [classical pathway](#) is triggered by activation of the C1-complex. The **C1-complex** is composed of 1 molecule of C1q, 2 molecules of C1r and 2 molecules of C1s, or $C1qr^2s^2$. This occurs when C1q binds to [IgM](#) or [IgG](#) complexed with [antigens](#). A single pentameric IgM can initiate the pathway, while several, ideally six, IgGs are needed. This also occurs when [C1q](#) binds directly to the surface of the pathogen. Such binding leads to conformational changes in the C1q molecule, which leads to the activation of two [C1r](#) molecules. C1r is a serine protease. They then cleave [C1s](#) (another serine protease). The $C1r^2s^2$ component now splits [C4](#) and then [C2](#), producing C4a, C4b, C2a, and C2b (historically, the larger fragment of C2 was called C2a but is now referred to as C2b). C4b and C2b bind to form the classical pathway C3-convertase (C4b2b complex), which promotes cleavage of C3 into C3a and C3b. C3b later joins with C4b2b to make C5 convertase (C4b2b3b complex).

Alternative pathway

The [alternative pathway](#) is continuously activated at a low level, analogous to a car engine at idle, as a result of spontaneous [C3](#) hydrolysis due to the breakdown of the internal thioester bond (C3 is mildly unstable in aqueous environment). The alternative pathway does not rely on pathogen-binding

antibodies like the other pathways.^[2] C3b that is generated from C3 by a C3 convertase enzyme complex in the fluid phase is rapidly inactivated by [factor H](#) and [factor I](#), as is the C3b-like C3 that is the product of spontaneous cleavage of the internal thioester. In contrast, when the internal thioester of C3 reacts with a hydroxyl or amino group of a molecule on the surface of a cell or pathogen, the C3b that is now covalently bound to the surface is protected from factor H-mediated inactivation. The surface-bound C3b may now bind [factor B](#) to form C3bB. This complex in the presence of [factor D](#) will be cleaved into Ba and Bb. Bb will remain associated with C3b to form C3bBb, which is the alternative pathway C3 convertase.^[citation needed]

The C3bBb complex is stabilized by binding oligomers of [factor P](#) (Properdin). The stabilized C3 convertase, C3bBbP, then acts enzymatically to cleave much more C3, some of which becomes covalently attached to the same surface as C3b. This newly bound C3b recruits more B, D and P activity and greatly amplifies the complement activation. When complement is activated on a cell surface, the activation is limited by endogenous complement regulatory proteins, which include [CD35](#), [CD46](#), [CD55](#) and [CD59](#), depending on the cell. Pathogens, in general, don't have complement regulatory proteins (there are many exceptions, which reflect adaptation of microbial pathogens to vertebrate immune defenses). Thus, the alternative complement pathway is able to distinguish self from non-self on the basis of the surface expression of complement regulatory proteins. Host cells don't accumulate cell surface C3b (and the proteolytic fragment of C3b called iC3b) because this is prevented by the complement regulatory proteins, while foreign cells, pathogens and abnormal surfaces may be heavily decorated with C3b and iC3b. Accordingly, the alternative complement pathway is one element of [innate immunity](#).^[citation needed]

Once the alternative C3 convertase enzyme is formed on a pathogen or cell surface, it may bind covalently another C3b, to form C3bBbC3bP, the C5 convertase. This enzyme then cleaves C5 to C5a, a potent [anaphylatoxin](#), and C5b. The C5b then recruits and assembles C6, C7, C8 and multiple C9 molecules to assemble the [membrane attack complex](#). This creates a hole or pore in the membrane that can kill or damage the pathogen or cell.

Lectin pathway

The [lectin](#) pathway is homologous to the classical pathway, but with the opsonin, [mannose-binding lectin](#) (MBL), and [ficolins](#), instead of C1q. This pathway is activated by binding of MBL to mannose residues on the pathogen surface, which activates the MBL-associated serine proteases, MASP-1, and MASP-2 (very similar to C1r and C1s, respectively), which can then split C4 into C4a and C4b and C2 into C2a and C2b. C4b and C2b then bind together to form the classical C3-convertase, as in the classical pathway. Ficolins are homologous to MBL and function via MASP in a similar way. Several single-nucleotide polymorphisms have been described in M-ficolin in humans, with effect on ligand-binding ability and serum levels. Historically, the larger fragment of C2 was named C2a, but it is now referred to as C2b.^[8] In invertebrates without an adaptive immune system, ficolins are expanded and their binding specificities diversified to compensate for the lack of pathogen-specific recognition molecules.

6th SEMESTER

ZOO616DA: ZOOLOGY – IMMUNOLOGY

Unit 4th

4.1 ,4.2 Gel and Coombs Classification of hypersensitivity

Hypersensitivity (also called hypersensitivity reaction or intolerance) refers to undesirable reactions produced by the normal immune system, including allergies and autoimmunity. They are usually referred to as an over-reaction of the immune system and these reactions may be damaging, uncomfortable, or occasionally fatal. Hypersensitivity reactions require a pre-sensitized (immune) state of the host. They are classified in four groups after the proposal of P. G. H. Gell and Robin Coombs in 1963.

Several types of hypersensitive reactions can be identified, reflecting differences in the effector molecules generated in the course of the reaction. Gell and Coomb described four types of hypersensitivity reactions (Types I, II, III and IV). The first three types are antibody-mediated and the fourth type is mediated mainly by T-cell and macro-phases i.e. cell-mediated

Table 11.1: Gell and Coombs classification of hypersensitive reactions

Type	Descriptive name	Initiation time	Mechanism	Typical manifestations
Delayed Reactions				
Type I	IgE-mediated hypersensitivity	2-30 min	Ag induces cross-linkage of IgE bound to mast cells and basophils with release of vasoactive mediators	Systemic anaphylaxis Localized anaphylaxis Hay fever Asthma Hives Food allergies Eczema
Type II	Antibody mediated cytotoxic hypersensitivity	5-8 h	Ab directed against cell surface antigens mediates cell destruction via complement activation or ADCC	Blood-transfusion reactions Erythroblastosis fetalis Autoimmune haemolytic anaemia
Type III	Immune complex mediated hypersensitivity	2-8 h	Ag-Ab complexes deposited in various tissues induce complement activation and an ensuing inflammatory response	Localized Arthus reaction Generalized reactions Serum sickness Glomerulonephritis Rheumatoid arthritis Systemic lupus erythematosus
Type IV	Cell-mediated hypersensitivity	24-72 h	Sensitized T _{DTH} cells release cytokines that activate macrophages or T _C cells, which mediate direct cellular damage	Contact dermatitis Tubercular lesions Graft rejection

1. Type I Hypersensitivity:

Type I hypersensitive reactions are the commonest type among all types which is mainly induced by certain type of antigens i.e. allergens. Actually anaphylaxis means “opposite of protection” and is mediated by IgE antibodies through interaction with an allergen.

(i) Mode of Action:

During the activity, this class of antibody (IgE) binds with high affinity to F_c (Fragment crystallized) receptors on the surface of constant domains of tissue mast cells and blood basophils. Such IgE-coated mast cells and basophils are said to be sensitized. When the individual is exposed to the same allergen again, then it cross-links the membrane bound IgE on sensitized mast cells and basophils and degranulation of those cells result (Fig. 11.3).

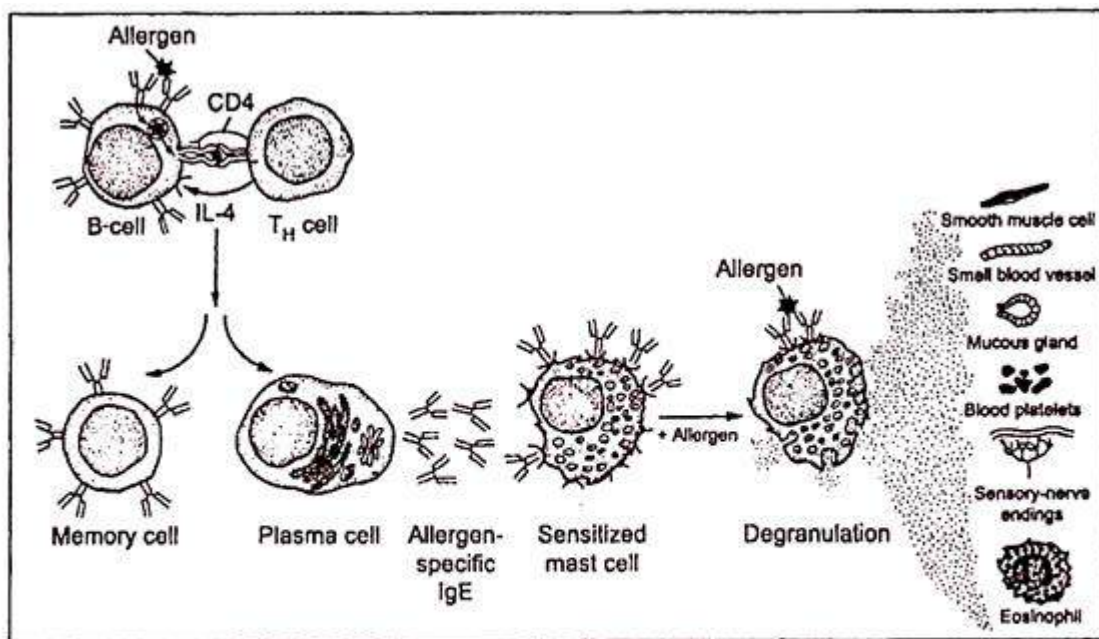

Fig. 11.3: General mechanism underlying a type-I hypersensitive reaction. Exposure to an allergen activates B-cells to form IgE-secreting plasma cells. The secreted IgE molecules bind to IgE-specific F_c receptors on mast cells and blood basophils. Second exposure to the allergen leads to cross-linking of the bound IgE, triggering the release of pharmacologically active mediators from mast cells and basophils. The mediators cause smooth-muscle contraction, increased vascular permeability and vasodilation

(ii) Biological effects:

1. Normally anaphylactic responses are of a mild type producing symptoms— like hay-fever, running nose, skin eruptions called as ‘nives’ or breathing difficulties.
2. The pharmacologically active mediators released from the granules exert biological effects on the surrounding tissues.
3. In some cases, the responses may be severe, develop within a few minutes (2-30 mins) and may even cause death before any medical help is called anaphylactic shock.
4. The principal effects of vasodilation and smooth muscle contraction may be either systematic or localized.

(iii) Components of type-I reactions:

There are different types of components which are required for type-1 reactions:

1. Different allergens
2. Reaginic antibody (IgE)
3. Mast cells and basophils
4. IgE—binding F_c receptors.
5. High—affinity and low-affinity receptors.

(iv) Therapy for Type-I hypersensitivity:

1. The first step in controlling type I is to identify the offending allergen and avoid contact if possible.
2. Removal of house pets, dust-control measures.
3. Repeated injections of increasing doses of allergens called hypo sensitization.
4. Enhancement of phagocytosis by IgG antibody which is referred to a blocking antibody because it competes for the allergens, binds and forms a complex that can be removed by phagocytosis.
5. Successful use of anti-histamine drugs result better with respect to type I hypersensitivity.

2. Type II Hypersensitivity:

Type II hypersensitive reactions are those in which tissue or cell damage is the direct result of the actions of antibody and complement.

(i) Mode of action:

This type of reaction is resulted by blood- transfusion reactions in which host antibodies react with foreign antigens present on the incompatible transfused blood cells and mediate destruction of these cells.

Antibody can mediate cell destruction by activating the complement system to create pores in the membrane of the foreign cell by forming membrane attack complex (MAC). This can also be mediated by antibody dependent cell-mediated cytotoxicity (ADCC).

A faulty cross-matching leads to haemolysis of the donor's erythrocytes in the blood vessels of the recipient due to the alloantigen of the donor's erythrocytes react with the antibodies in the serum of the recipient and in combination with activated complement, the erythrocytes undergo haemolysis.

(ii) Biological effect:

1. Haemolytic disease of the newborn develops when maternal IgG antibodies specific for foetal blood-group antigens cross the placenta and destroy foetal red blood cells. Severe haemolytic disease of the new born is called erythroblastosis foetalis, when an Rh^+ foetus expresses an Rh antigen on its blood cells that the Rh^- mother does not express it
2. Certain antibiotics (e.g. penicillin, cephalosporin and streptomycin) can absorb non- specifically to proteins on RBC membranes, forming a complex similar to a hapten-carrier complex and gradually induces anaemia called drug-induced haemolytic anaemia

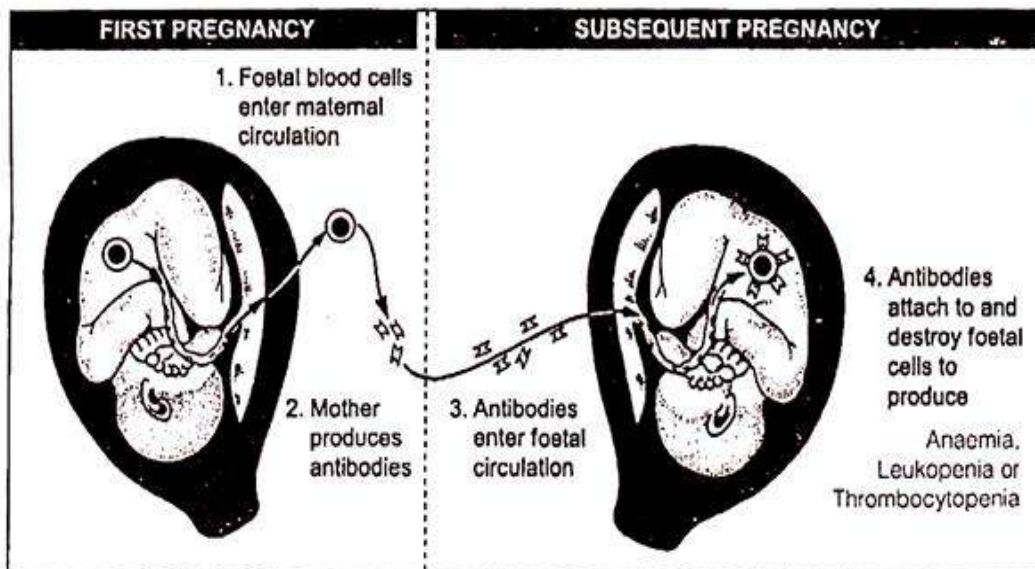
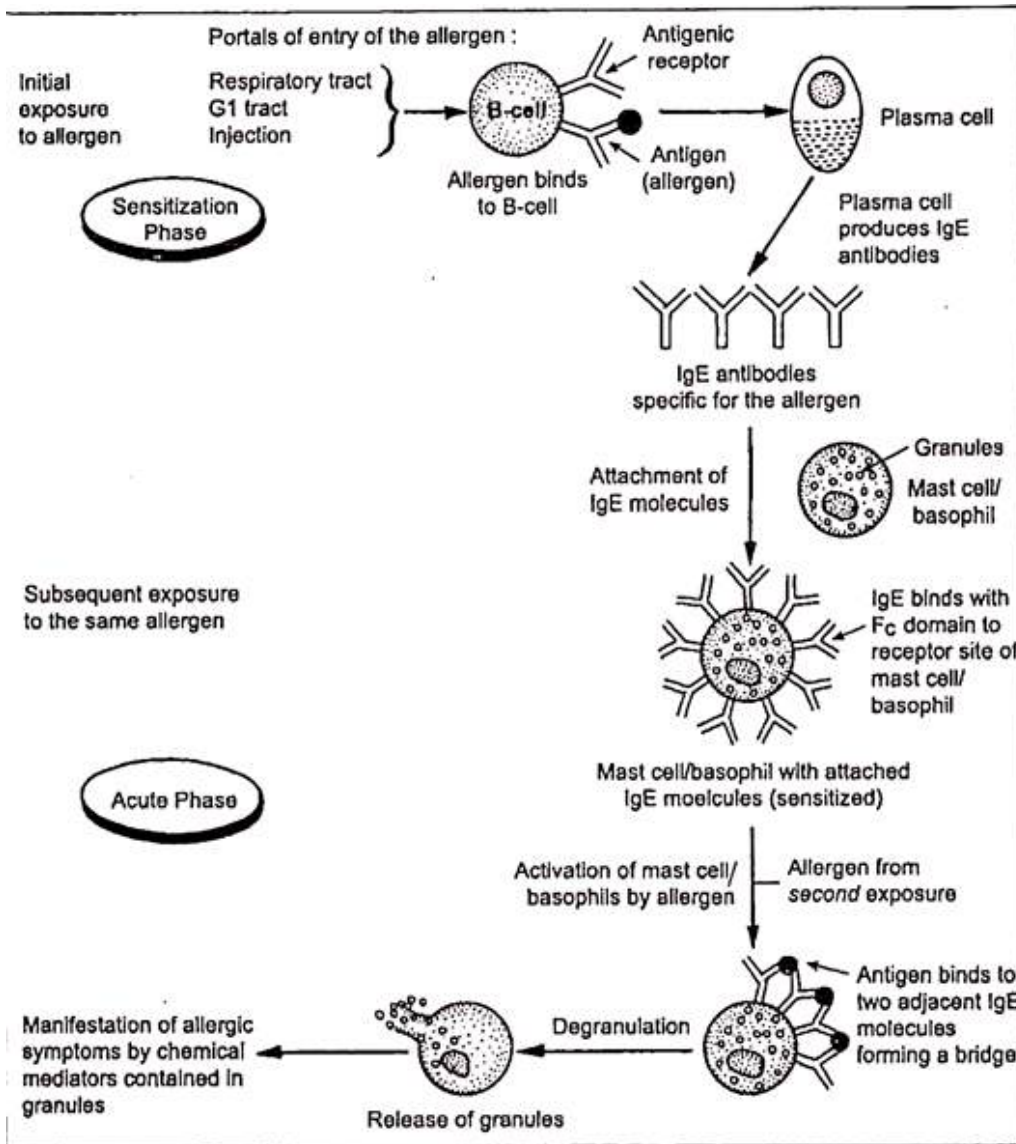

3. Type III Hypersensitivity:

When an antigen enters within the body then the antibody reacts with antigen and generates immune complex. This immune complex gradually facilitates removal of antigen by phagocytic activity of body. Large amount of immune complexes lead to tissue-damaging Type III hypersensitivity. For this reason Type III is called immune complex hypersensitivity.

(i) Mode of action:

1. These reactions develop when immune complexes activate the complement system's array of immune effector molecules. Complement components (C3a, C4a, C5a) split and produce anaphylatoxins which cause localized mast cell degranulation and increase local vascular permeability.
2. When formed bulky antigen-antibody complexes aggregate and combine with the activated complement, they chemotactically attract the polymorphonuclear leucocytes. These cells release lysosomal enzymes in large quantities to cause tissue damage.

(ii) Biological effect:

1. The recipient of a foreign antiserum develops antibodies, specific for the foreign serum proteins from circulating immune complexes and within days or weeks after exposure to foreign serum antigens, an individual starts to develop serum sickness including fever, weakness, vasculitis (rashes) with edema, erythema, lymphadenopathy, arthritis and glomerulonephritis.
2. Due to deposition of IgG antigen complexes in the blood vessels cause local damage and deposit in blood vessels of kidney glomeruli called Arthus Reaction.
3. Inhalation of bacteria and fungal spores gives rise to a disease called farmer's lung forming immune complexes in the epithelial layers of the respiratory tract.
4. Another type of hypersensitive reaction is known as lupus i.e. systemic lupus erythematosus. It is produced as a result of interaction of IgG and the nucleoproteins of the disintegrated leucocytes (auto-antigens). Lupus is an autoimmune disease.

4. Type IV Hypersensitivity:

Type IV hypersensitivity is the only type of delayed hypersensitivity. It is mainly controlled by T-cells, macrophages and dendritic cells. It is not the instant response but it is manifested after the second exposure to an allergen. The appearance of allergic symptoms come in delay.

(i) Mode of action:

Delayed hypersensitivity is maintained by T- lymphocytes. T-cells (lymphocytes) have two main types—the CD4⁺ cells and CD8⁺ cells. Type IV hypersensitivity requires CD4⁺ type. The special group of CD4⁺ cells take part in type IV hypersensitivity and are called T-D cells (delayed). Again T-helper cell (T_H cell) includes T-D cells which constitutes the bulk of CD4⁺ T-cells. T_H cells are again distinguished into T_{H-1} and T_{H-2} type, of which T_{H-2} cells are mainly responsible for activation of B-cell to produce immunoglobulins and T_{H-1} cells are involved in causing the inflammatory responses including delayed hypersensitivity reactions .

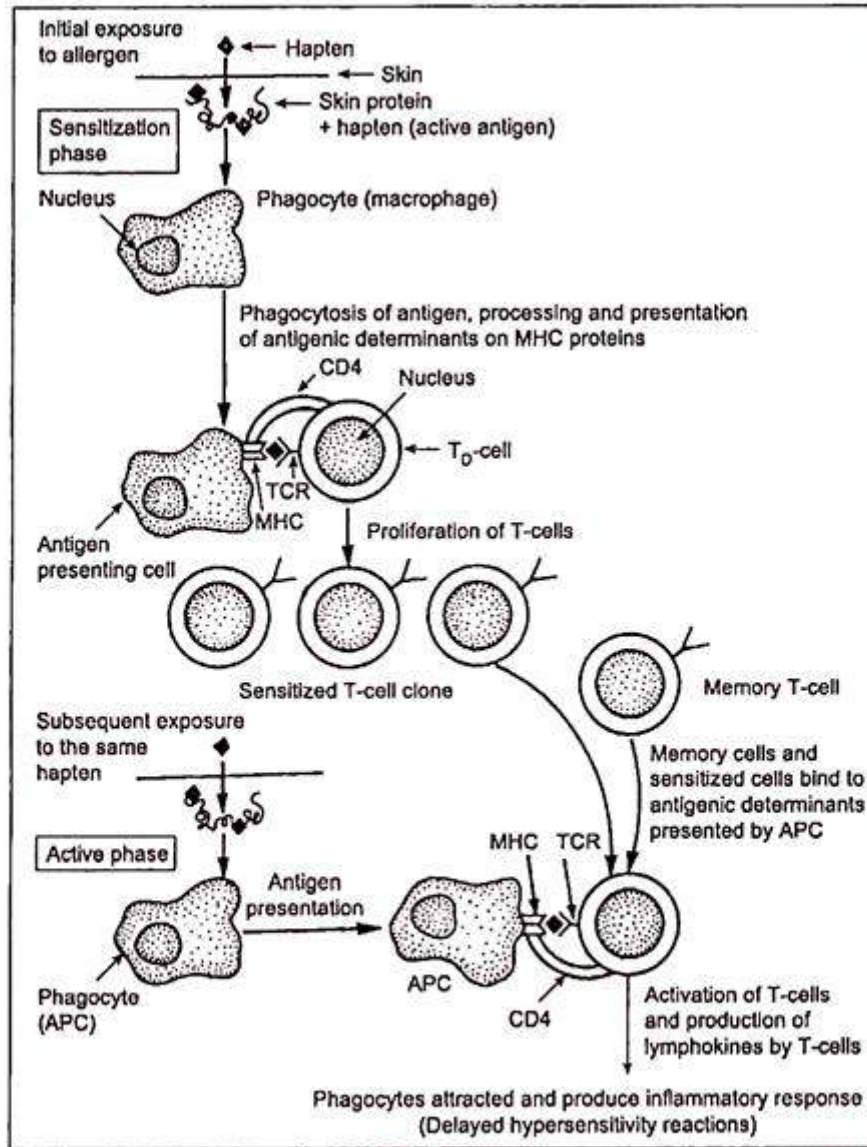

Fig. 11.6: Delayed hypersensitivity reactions like skin-contact sensitivity to small molecules acting as haptens. During the sensitization phase, exposure leads to formation of sensitized T-cells. A subsequent exposure to the same hapten stimulates the sensitized T-cells to produce lymphokines which attract phagocytic cells and cause an inflammatory skin response (allergic dermatitis)

(ii) Biological effect:

1. A microbial agent that elicits a delayed hypersensitivity is tuberculin which is a purified protein derivative (PPD) of tubercle bacilli (*Mycobacterium tuberculosis*). *Mycobacterium leprae*, the microbial agents also stimulate delayed hypersensitivity.
2. The tuberculin skin test (Mantoux test) is used to determine if a person has T-cell mediated reactivity towards tubercle bacilli (also known as Koch's bacilli).

4.3 Introduction to concepts of autoimmunity and immunodeficiency

Autoimmune Disorders:

(i) Autoimmunity:

A fundamental property of the immune system is its ability to recognize the body's own cells and the antigens present in them as self-antigens. Under normal conditions, the immune system does not attack self-antigens. This ability — tolerance, develops while the immune cells like B-cells and T-cells mature from their precursor cells.

During maturation, the cells which bind to self-antigens (MHC proteins) are eliminated, while a small proportion of the total population of lymphocytes which does not react with self-molecules survive. Thus, tolerance can be defined as immunological unresponsiveness to self-antigens which are present at birth, because the elimination process takes place mainly in the embryonic cells.

Autoimmunity refers to the state when tolerance to self-antigens breaks down and the immune system attacks the self-antigens. When such attack results in damage of tissues and organs of the body through its own immune system, autoimmune diseases develop. Such diseases may arise through production of antibodies which interact with self-antigens, or through activation of T-cells capable of attacking self-cells.

(ii) Causes of Tolerance Failure:

The mechanisms involved in development of autoimmune diseases due to break-down of self-tolerance are not well-understood. Some of the possible causes of tolerance failure are briefly discussed below. One possible mechanism is molecular mimicry.

When a foreign antigen, like a virus or a microbe, possesses antigenic determinants which are identical or closely similar to a self-antigenic determinant, the immune system fails to distinguish them and may cross-react with both the non-self as well as the self-antigen causing destruction of both the pathogen and the self-cells.

An example of such molecular mimicry is the similarity of a protein of hepatitis C virus and a self-protein, both having a more or less similar amino acid sequence. Another example is provided by a common antigenic determinant present in Group A Streptococcus and heart muscle cells. Cross-reactive antibodies produced by the bacterial antigen also react with the self-antigens resulting in damage of heart (rheumatic heart disease).

Another cause of autoimmune response is polyclonal activation of lymphocytes. Some antigens of microbial origin can activate lymphocytes irrespective of their antigenic specificity e.g. the lipopolysaccharides of Gram-negative bacteria and Epstein-Barr virus.

Because these agents provoke immune response to produce many clones of antibody producing B-cells, they are said to be polyclonal and the antibodies show cross-reactivity with self as well as non-self antigens. Such polyclonal activation of B-cells is believed to by-pass the participation of T-helper cells, which is normally required for B-cell activation (T-independent antigens).

Autoimmunity may also result from certain drugs when their molecules act like haptens and are chemically attached to the surface antigens of body cells. This leads to alteration of their antigenic specificity, so that the immune system recognizes those body cells as non-self and attacks them.

An example of such drug-induced autoimmune disease is thrombocytopenia, a condition of abnormally low count of platelets in blood. Drugs, like aspirin, antihistaminic and some antibiotics are among the agents which result in impaired blood-clotting due to reduced platelet (thrombocytes) count.

Still another possibility of origin of autoimmunity is that certain cells and tissues are either anatomically isolated from the immune system in the embryonic stage when tolerance develops, or they are absent at birth. Such cells and tissues (antigens) are recognized by the body's immune system as non-self.

Normally, these antigens remain isolated from the immune system (sequestered), but infection or trauma may expose them to the action of immune cells and molecules, resulting in autoimmune responses. The examples of such sequestered antigens are the lens tissue of the eye, nerve cells; spermatozooids etc.

(iii) Some Autoimmune Diseases:

Grave's disease:

This disease is caused by antibody-mediated stimulation of the thyroid gland resulting in enlargement of the gland (goiter) and production of excess of thyroid hormone. The antibodies bind to the receptors of the gland cells which normally function as receptors for the thyroid stimulating hormone (TSH) produced by the pituitary gland. Thus, the TSH-receptor act as antigen for the antibody and the binding leads to long-standing thyroid stimulation causing Grave's disease.

Myasthenia gravis:

It is a cytotoxic autoimmune disease affecting muscles. The disease is mediated by antibodies which bind to the membrane of muscle fibres and combine with receptors that normally accept acetyl choline. As a result, the reception of nerve impulses by the muscle fibres is hampered and muscle activity is seriously affected. In an advanced stage, the disease may prove fatal due to arrest of respiration caused by loss of activity of the muscles of diaphragm and chest.

Systemic lupus erythematosus (SLE):

It is considered as an autoimmune disease, because antibodies are formed in one's own body against the body's disintegrating leucocytes.

The nucleoproteins of these leucocytes act as auto-antigens. The complexes formed by combination of these auto-antigens and their complimentary antibodies stimulate complement and produce local skin rash on face (butterfly rash), or the complexes may also produce lesions in blood vessels of kidney and heart.

Rheumatoid arthritis:

In this crippling autoimmune disease, immune complexes are deposited in the joints producing chronic inflammation, eventually resulting in serious damage of cartilages and bones. The immune complexes, also known as rheumatoid factors are formed by binding of IgM molecules to the Fc-domains of IgG antibodies and complement proteins. As the constituents of rheumatoid factors come from the same person, the disease is considered as an autoimmune one.

Insulin-dependent diabetes mellitus:

This is a cell-mediated autoimmune disease which results in destruction of the insulin-secreting β - cells of pancreas by T-cells. A host of other autoimmune diseases are also known. Among them are Addison's disease in which adrenocortical cells (ACTH receptors) act as antigen, Hashimoto's thyroiditis in which the auto-antigen is thyroglobulin, Good pasture's syndrome in which the basement membrane of kidney and lungs (type of collagen) act as auto-antigen, and other diseases.

(iv) Factors Predisposing Autoimmune Diseases:

Genetic factors:

The inheritance pattern of human leucocyte antigen (HLA) controlled by the MHC genes is thought to be responsible for relative proneness to autoimmune diseases. Certain autoimmune diseases, like those affecting thyroid gland, are known to occur in genetically related females. Also, mutations in genes controlling activation of lymphocytes and synthesis of complement proteins are considered to have a major role in increasing risk of SLE-like diseases.

Age and sex:

Autoimmune diseases generally appear in aged persons, possibly due to natural decay of the immune system which, due to aging, becomes less efficient in regulation. In general, women have a greater risk for developing autoimmune diseases than men.

For example, SLE and Grave's diseases occur predominantly in women. The risk factors are respectively 10 and 7 times higher than that of men. The endocrine hormones are considered as important predisposing factors for this differential risk.

This is supported by animal experiments. Removal of ovaries of female mice makes them more resistant to autoimmune diseases, suggesting that the ovarian hormone, oestrogen, plays an important role. Application of the male sex hormone, testosterone, also makes the female mice more resistant to autoimmune diseases, like SLE.

Infection:

Certain pathogenic agents, like Epstein-Barr virus, streptococci, malarial parasites, mycoplasmas etc. are known to cause specific autoimmune diseases. Some of these agents have antigenic determinants which have close structural similarity to the antigenic determinants of body cells (self-antigens). These microbial antigenic determinants induce formation of antibodies which can also bind to the self-antigens producing autoimmune reactions (molecular mimicry).

For example, the heat- shock proteins of many microorganisms possess a high degree of similarity in amino acid sequences with the corresponding human proteins. As a consequence, the antibodies produced against the microbial heat-shock proteins show cross-reactivity also to human proteins producing autoimmune responses.

Immunodeficiency Diseases:

The immune system is primarily responsible for protection against infections diseases. This function of the immune system is carried out by its different components, e.g. B-cells produce antibodies responsible for humoral immunity, T-cells are responsible for cell-mediated immunity, as well as for activation of B-cells and macrophages, the complement helps in T-cell function and in attracting phagocytes, etc.

Immune deficiency can affect any one or more of these components of the immune system. As a result, an individual suffering from immunodeficiency falls prey to repeated infections by one or more of the pathogenic agents.

Immunodeficiency can be congenital or acquired:

(i) Congenital Immune Deficiency:

An individual born with a defective immune system suffers from congenital or primary immune deficiency. Such deficiency arises from genetic changes which are inherited. Presumably, mutations in the genes controlling the formation of different components of the immune system account for the origin of the congenital immune deficiencies.

For example, in a disease known as Bruton's agammaglobulinemia, mature B-cells fail to develop from the pre-B cells in the bone marrow. As a result, a patient suffering from this disease cannot produce immunoglobulin and becomes highly susceptible to infectious diseases, specially those caused by encapsulated cocci, like streptococci, staphylococci and pneumococci. Such susceptibility is probably due to the lack of IgG antibodies which opsonize the capsulated bacteria and facilitate their elimination by phagocytosis. Usually, a child born with such a defect does not survive long, unless specially protected from infectious diseases.

Deficiency in humoral immunity may also arise from defective regulation of T-helper cells which secrete specific cytokines to induce proliferation, activation and transformation of B-cells into plasma cells. Also, different types of T-helper cells, like T_H-1 and T_H-2 cells, participate in the class switching in antibody formation through specific cytokines. Thus, any mutations in the genes coding for these proteins (cytokines) may have a pronounced effect on their activity and function.

Not only cytokines, but other protein ligands present on B-cells and T-cells which take part in their binding with other effector cells are also liable to modification through mutation. For example, an activated B-cell initially producing IgM switches over to production of IgG by binding a T_H-1 cell with the CD40 protein ligand.

The binding induces the T_H-1 cell to produce the cytokine, interferon γ , which makes the switchover possible. In an immune deficiency disease, known as hyper-IgM syndrome, the affected person contains high concentration of IgM, but little or no IgG. This defect arises from a mutation in the gene coding for CD40 protein of B-cells. As a result, the class-switching from IgM to IgG is blocked.

Just as defects in B-cells and T-helper cells may lead to deficiencies in the humoral immune system, so can the defects in cytotoxic T-cells lead to deficiency in the cell-mediated immunity.

In an immune deficiency condition, called DiGeorge syndrome, the mature thymus gland is absent in an affected individual. As a result, cell-mediated immunity is seriously affected and the person becomes highly susceptible to infections by fungi, viruses and protozoa. As cytotoxic T-cells chiefly provide immunity against intracellular pathogens and large parasites, their absence or depletion in number makes the immuno-deficient persons specially susceptible to those pathogenic agents.

Another immune deficiency disease, known as severe combined immunodeficiency, results from inherent defects in the precursor stem cells from which B-cells and T-cells are formed. The defense of the body against external agents may also be seriously affected due to defects in the phagocytic cells and in the process of phagocytosis itself. Removal of non-self antigens by phagocytosis is one of the most important mechanisms in both innate and acquired defense.

Defects in phagocytes may be due to inherent abnormalities in the stem cells which give rise to the monocytes and polymorphonuclear cells. The defect may result in abnormal reduction in number of phagocytes or may affect the process of phagocytosis. In a type of immune deficiency, known as neutropenia, a person has too few neutrophils. In another disease, called Chediak-Higashi syndrome, the phagocytic process is defective in that the fusion of a phagosome and lysosome in the phagocytic cell does not take place.

As a result, the lysosomal enzymes are not released to kill the ingested pathogen. In still another type of defect involving margination, the phagocytes lose the ability to transmigrate from the capillaries into tissues, so that they cannot reach the site of inflammation.

For transmigration, the neutrophils and monocytes must first adhere to the endothelial cells of capillaries. This requires a protein, known as adhesion factor. In defective leucocytes, this adhesion factor is lacking.

Apart from the congenital defects in the cellular components, immune deficiency may be due to abnormal or absence of one or more of the complement proteins. These proteins play a variety of important roles in both innate and acquired defense of the body. Of special importance is a defective C3 complement component.

A person deficient in this protein becomes highly susceptible to recurrent infection of capsulated pathogens like *Streptococcus*, *Neisseria* etc. This is due to the fact that the subcomponent C3b is an important opsonin which binds to both the bacterial surface antigens as well as to the specific receptors of neutrophils, thereby facilitating phagocytosis of the microbial cells.

Similarly, deficiency in other complement components, like C1, C2 etc., leads to defects in elimination of antigen-antibody complexes and may cause diseases like lupus (SLE). Again, defects in the complement components which build up the membrane attack complex causing cytolysis of microbes necessarily increase the susceptibility of the affected person to microbial pathogens.

(ii) Acquired Immune Deficiency:

Immune deficiency may be acquired through the normal process of aging or senescence, or by infection of the retroviruses — human immunodeficiency viruses (HIV-1 and HIV-2). Infection by HIV leads to the development of the currently most dreadful infectious disease, acquired immunodeficiency syndrome (AIDS).

Immune deficiency acquired by aging develops due to senescence of the immune system which becomes less responsive to foreign antigens. In particular, T-cell function deteriorates with aging due to the lack of an active thymus-gland. This gland is gradually replaced by fat with aging and, after the age of 60 or so, a person has to depend on T-cells produced earlier, because fresh T-cell formation stops.

Similarly, humoral immunity also shows senescence-associated changes. B-cell production in bone-marrow subsides and, more importantly, the antibodies produced by them show a decreased affinity to antigens. B-cell activation which requires participation of T-helper cells also declines, because of decrease in T-cell population.

Thus, the combined effects of the cell-mediated and the antibody-mediated immunity contribute to the senescence of the overall immune system. As a result, elderly persons become more susceptible to infectious diseases.

Besides the intrinsic factors related to aging, other external factors may exert adverse effects on the immune system producing immune deficiency. Among these factors, two important ones are malnutrition and application of cytotoxic drugs.

Malnutrition caused by protein deficiency may affect the normal development of the immune-responsive cells and molecules at any age. Similarly, lack of certain metal ions — like iron and zinc in the diet — may have an adverse effect on the development of immune system.

Cytotoxic drugs and other physical agents used to kill or suppress tumour cells profoundly affect the overall immune system. These anti-tumour agents not only kill the target cells, but also cells essential for the immune-function, like the stem cells and different types of leucocytes.

Acquired immunodeficiency syndrome (AIDS):

The most important among the acquired immunodeficiency diseases is AIDS. About 50 million people are suffering from AIDS at present (2005) throughout the world, with 10% of them (5 million) in India. The main causal agent is HIV-1 which is worldwide in distribution.

A second virus, HIV-2, mainly restricted to West Africa, also leads to development of AIDS, but more slowly than HIV-1. Both viruses belong to the class Retrovirus (also known as lentiviruses) and produce DNA in the infected cells from the genomic RNA consisting of two identical molecules. The virions contain the enzyme reverse transcriptase required for making DNA from the viral RNA.

The virions are enveloped and contain spikes of glycoproteins having molecular weight of 120 kd. With the help of these glycoprotein spikes, technically designated as gp 120 the virions bind to specific receptors present on target cells.

HIVs probably originated from the Simian immunodeficiency virus (SIV) which infects monkey and chimpanzee. The probable location of origin of HIV is thought to be central Africa. SIV has more similarity to HIV-2 than HIV-1.

The disease known as AIDS is the consequence of HIV infection, though there is usually a long gap between infection and the manifestation of symptoms. AIDS was first detected by the Centre for Disease Control and Prevention, Atlanta, USA in June, 1981 among a group of 5 gay men suffering from an unusual and rare pneumonia caused by a bacterium, *Pneumocystis carinii* and a type of skin cancer, called Kaposi's sarcoma. The association of these diseases with a virus was suspected and the virus was first identified in 1984. It was officially designated as human immunodeficiency virus (HIV) in 1986.

HIV attacks specifically cells having CD4 receptors. These receptor proteins are present on the surface of T-helper cells, both T_H-1 and T_H-2 , as well as on macrophages and dendritic cells. Apart from the CD4 receptors, co-receptors are also required for binding of HIV to target cells.

The co-receptors are specific surface proteins of target cells which act as receptors of cytokines under normal conditions. The co-receptor on T-cells are CXCR4 and those on macrophages are CCR5, where CC means two adjacent cystein residues at the beginning of the polypeptide of the co-receptor protein. CXC means two cystein molecules intervened by another amino acid (X).

The HIV virion binds to the target cell receptor-co-receptor complex with the help of its glycoprotein spikes (gp 120) as shown diagrammatically in Fig. 10.62:

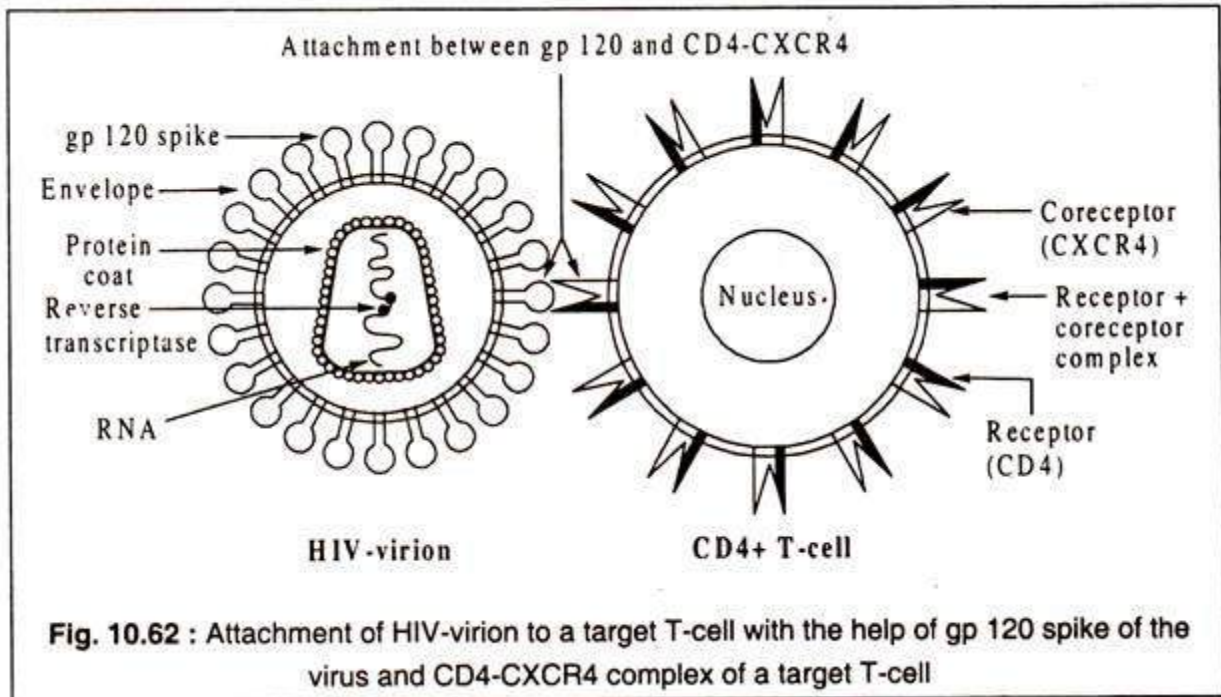

After entry into the target cell, viral RNA is released by un-coating and it is transcribed into complementary ds-DNA with the help of viral reverse transcriptase. The DNA is then integrated into one of the chromosomes of the target cell and becomes a provirus. In the provirus state, the virus is no longer susceptible to the attack of the immune system of the body, but it retains the capacity to produce new virus particles.

These progeny virus particles can attack macrophages where they hide as latent virions in the vacuoles of these cells. Either as provirus or latent virus, HIV can evade the HIV- antibodies produced by the body in response to the HIV. Though HIV-antibodies are produced in the serum of the infected person, free viruses are not present in the blood stream at this stage of infection.

Another important feature of all retroviruses including HIVs is rapid change of antigenic specificity due to high rate of mutation. This property of retroviruses is due to their reverse- transcriptase activity which is used for transcribing virion-genome into pro-viral DNA.

In normal DNA replication by DNA-polymerase, the chance of incorporation of a wrong nucleotide in the elongating DNA molecule is eliminated by a corrective mechanism, called proof-reading, by the epsilon subunit of the DNA-polymerase molecule. The reverse-transcriptase lacks such a proof-reading mechanism. As a result, DNA transcribed from RNA contains numerous nucleotide replacements which cause genetic variations in retroviruses.

This inherent property of HIV has given rise to a large number of genetically distinct groups within HIV-1. These groups are called clades. The presence of many clades makes it difficult to develop strategies of control of these viruses either with drugs or by vaccination.

Development of symptoms of AIDS takes about 10 years from the initial infection by HIV in case of adults. The most common symptoms of fully developed AIDS are various infections caused by opportunistic organisms. These include *Pneumocystis carinii* causing an uncommon type of pneumonia, a number of fungi, like *Candida*, *Cryptosporidium*, *Cryptococcus* etc. and a virus, human herpes virus (HHV8), causing a type of cancer, Kaposi's sarcoma.

An AIDS patient falls prey to such opportunistic pathogens, because of total failure of the immune system (immunodeficiency) which increases gradually as the disease progresses. At the initial stage of infection, the loss of the main target cell which is CD4⁺ -cells is compensated by continuous production of fresh cells by the immune system.

With progress of the infection, the production of fresh T-cells cannot keep pace with loss of T-cells resulting from attack of HIV. The consequence is rapid reduction of T-cells. In a normal individual, the number of T-cells per microlitre of blood is about 1,000. This number often falls to less than 100 in an advanced AIDS patient.

The total break-down of the immune system in an AIDS patient is due mainly to the destruction of CD4⁺ T-cells i.e. T_H-cells. These cells play a central role in both antibody-mediated, as well as in cell-mediated immunity (Fig. 10.63). In humoral immunity, T_H-cells bind to B-cells and secrete cytokines which induce proliferation, activation and transformation of B-cells into antibody-manufacturing plasma cells. T_H-cells also activate macrophages by secreting specific cytokines.

Loss of this activity affects phagocytosis and antigen-presentation functions of macrophages as well as of dendritic cells. Besides, the virus can also directly attack these cells which possess CD4 receptors. T_H-cells are essential for activation of CD8⁺ T-cells into cytotoxic T-cells. Thus, depletion of T_H-cells also produces adverse effects on cell-mediated immunity. It is easily understandable, therefore, that the destruction of T_H-cells by HIV leads to an overall disruption of the whole immune system in an AIDS patient who becomes helpless to the attack of various pathogenic agents and finally succumbs to one or more of the infectious diseases.

4.4 Introduction to Vaccines

For many diseases, prevention is the best form of treatment, and few strategies for disease prevention are as effective as vaccination. Vaccination is a form of artificial immunity. By artificially stimulating the adaptive immune defenses, a vaccine triggers memory cell production similar to that which would occur during a primary response. In so doing, the patient is able to mount a strong secondary response upon exposure to the pathogen—but without having to first suffer through an initial infection. In this section, we will explore several different kinds of artificial immunity along with various types of vaccines and the mechanisms by which they induce artificial immunity.

Thousands of years ago, it was first recognized that individuals who survived a smallpox infection were immune to subsequent infections. The practice of inoculating individuals to actively protect them from smallpox appears to have originated in the tenth century in China, when the practice of variolation was described. Variolation refers to the deliberate inoculation of individuals with infectious material from scabs or pustules of smallpox victims. Infectious materials were either injected into the skin or introduced through the nasal route. The infection that developed was usually milder than naturally acquired smallpox, and recovery from the milder infection provided protection against the more serious disease.

Although the majority of individuals treated by variolation developed only mild infections, the practice was not without risks. More serious and sometimes fatal infections did occur, and because smallpox was contagious, infections resulting from variolation could lead to epidemics. Even so, the practice of variolation for smallpox prevention spread to other regions, including India, Africa, and Europe.

Although variolation had been practiced for centuries, the English physician Edward Jenner (1749–1823) is generally credited with developing the modern process of vaccination. Jenner observed that milkmaids who developed cowpox, a disease similar to smallpox but milder, were immune to the more serious smallpox. This led Jenner to hypothesize that exposure to a less virulent pathogen could provide immune protection against a more virulent pathogen, providing a safer alternative to variolation. In 1796, Jenner tested his hypothesis by obtaining infectious samples from a milkmaid's active cowpox lesion and injecting the materials into a young boy. The boy developed a mild infection that included a low-grade fever, discomfort in his axillae (armpit) and loss of appetite. When the boy was later infected with infectious samples from smallpox lesions, he did not contract smallpox. This new approach was termed vaccination, a name deriving from the use of cowpox (Latin *vacca* meaning "cow") to protect against smallpox. Today, we know that Jenner's vaccine worked because the cowpox virus is genetically and antigenically related to the *Variola* viruses that caused smallpox. Exposure to cowpox antigens resulted in a primary response and the production of memory cells that identical or related epitopes of *Variola* virus upon a later exposure to smallpox.

The success of Jenner's smallpox vaccination led other scientists to develop vaccines for other diseases. Perhaps the most notable was Louis Pasteur, who developed vaccines for rabies, cholera, and anthrax. During the twentieth and twenty-first centuries, effective vaccines were developed to prevent a wide range of diseases caused by viruses (e.g., chickenpox and shingles, hepatitis, measles, mumps, polio, and yellow fever) and bacteria (e.g., diphtheria, pneumococcal pneumonia, tetanus, and whooping cough,).

Classes of Vaccines

For a vaccine to provide protection against a disease, it must expose an individual to pathogen-specific antigens that will stimulate a protective adaptive immune response. By its very nature, this entails some risk. As with any pharmaceutical drug, vaccines have the potential to cause adverse effects. However, the ideal vaccine causes no severe adverse effects and poses no risk of contracting the disease that it is intended to prevent. Various types of vaccines have been developed with these goals in mind.

Live Attenuated Vaccines

Live attenuated vaccines expose an individual to a weakened strain of a pathogen with the goal of establishing a subclinical infection that will activate the adaptive immune defenses. Pathogens are attenuated to decrease their virulence using methods such as genetic manipulation (to eliminate key virulence factors) or long-term culturing in an unnatural host or environment (to promote mutations and decrease virulence).

By establishing an active infection, live attenuated vaccines stimulate a more comprehensive immune response than some other types of vaccines. Live attenuated vaccines activate both cellular and humoral immunity and stimulate the development of memory for long-lasting immunity. In some cases, vaccination of one individual with a live attenuated pathogen can even lead to natural transmission of the attenuated pathogen to other individuals. This can cause the other individuals to also develop an active, subclinical infection that activates their adaptive immune defenses.

Disadvantages associated with live attenuated vaccines include the challenges associated with long-term storage and transport as well as the potential for a patient to develop signs and symptoms of disease during the active infection (particularly in immunocompromised patients). There is also a risk of the attenuated pathogen reverting back to full virulence. Table 1 lists examples live attenuated vaccines.

Inactivated Vaccines

Inactivated vaccines contain whole pathogens that have been killed or inactivated with heat, chemicals, or radiation. For inactivated vaccines to be effective, the inactivation process must not affect the structure of key antigens on the pathogen.

Because the pathogen is killed or inactive, inactivated vaccines do not produce an active infection, and the resulting immune response is weaker and less comprehensive than that provoked by a live attenuated vaccine. Typically the response involves only humoral immunity, and the pathogen cannot be transmitted to other individuals. In addition, inactivated vaccines usually require higher doses and multiple boosters, possibly causing inflammatory reactions at the site of injection.

Despite these disadvantages, inactivated vaccines do have the advantages of long-term storage stability and ease of transport. Also, there is no risk of causing severe active infections. However, inactivated vaccines are not without their side effects. Table 1 lists examples of inactivated vaccines.

Subunit Vaccines

Whereas live attenuated and inactive vaccines expose an individual to a weakened or dead pathogen, **subunit vaccines** only expose the patient to the key antigens of a pathogen—not whole cells or viruses. Subunit vaccines can be produced either by chemically degrading a pathogen and isolating its key antigens or by producing the antigens through genetic engineering. Because these vaccines contain only the essential antigens of a pathogen, the risk of side effects is relatively low. Table 1 lists examples of subunit vaccines.

Toxoid Vaccines

Like subunit vaccines, **toxoid vaccines** do not introduce a whole pathogen to the patient; they contain inactivated **bacterial toxins**, called toxoids. Toxoid vaccines are used to prevent diseases in which bacterial toxins play an important role in pathogenesis. These vaccines activate humoral immunity that neutralizes the toxins. Table 1 lists examples of toxoid vaccines.

Conjugate Vaccines

A **conjugate vaccine** is a type of subunit vaccine that consists of a protein conjugated to a capsule polysaccharide. Conjugate vaccines have been developed to enhance the efficacy of subunit vaccines against pathogens that have protective polysaccharide capsules that help them evade **phagocytosis**, causing invasive infections that can lead to **meningitis** and other serious conditions. The subunit vaccines against these pathogens introduce T-independent capsular polysaccharide antigens that result in the production of antibodies that can opsonize the **capsule** and thus combat the infection; however, children under the age of two years do not respond effectively to these vaccines. Children do respond effectively when vaccinated with the conjugate vaccine, in which a protein with **T-dependent antigens** is conjugated to the capsule polysaccharide. The conjugated protein-polysaccharide antigen stimulates production of antibodies against both the protein and the capsule polysaccharide. Table 1 lists examples of conjugate vaccines.