

Sensors and Actuators

DR. T. LAKSHMIBAI





SENSORS AND ACTUATORS

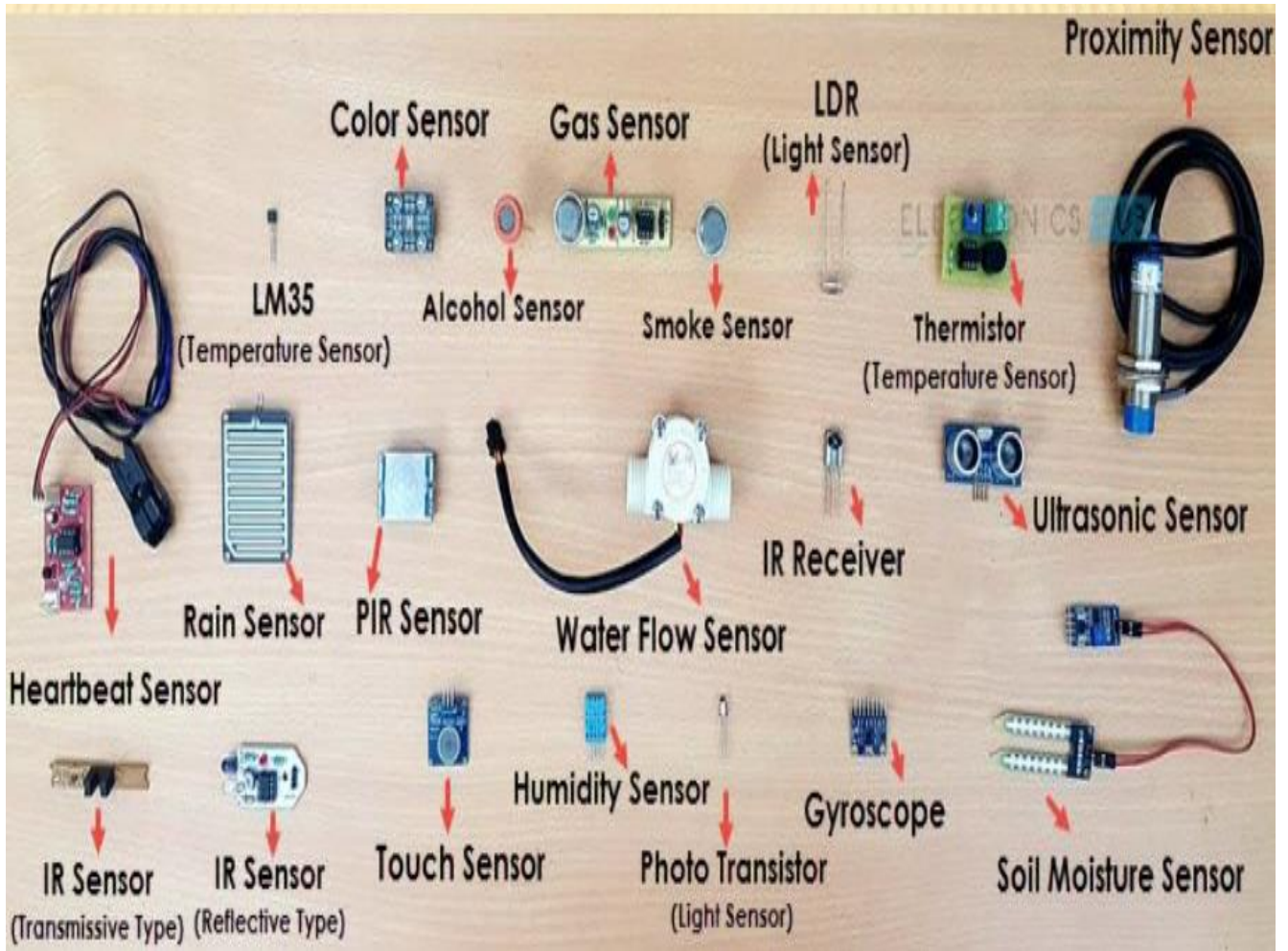

PREPARED BY

DR. T.LAKSHMIBAI, A.P/EIE

DEPARTMENT OF ELECTRONICS & INSTRUMENTATION
ENGINEERING
SCSVMV

Lecture notes on Sensors and Actuators

SEMESTER	SUBJECT CODE	NAME OF THE PAPER	CREDIT
III	BMTF183T60	Sensors and Actuators	3

Prepared by: **Dr.T.Lakshmibai, Assistant Professor/EIE, SCSVMV.**

INDEX

Sl.No	Table of Contents	Page No.
1	Aim & Objectives	3
2	Prerequisite	3
3	Syllabus	3
4	UNIT I	5
5	UNIT II	32
6	UNIT III	57
7	UNIT IV	97
8	UNIT V	125
9	Conclusions	154
10	Video links	154
11	References	155
12	Question bank	155

Aim & objectives: To study the various instruments displays and panels in the aircraft and to discuss the cock pit layout. The objective of the study of aircraft instrumentation is to know the functions of all the flight, gyroscopic and power plant instruments in the aircraft and enable the learners to rectify the problems occurring in the aircraft.

Prerequisite: Basic electronics, Measurements and Instruments

SYLLABUS:

UNIT – I SENSORS

Difference between sensor, transmitter and transducer - Primary measuring elements - selection and characteristics: Range; resolution, Sensitivity, error, repeatability, linearity and accuracy, impedance, backlash, Response time, Dead band. Signal transmission - Types of signal: Pneumatic signal; Hydraulic signal; Electronic Signal.

Principle of operation, construction details, characteristics and applications of potentiometer, Proving Rings, Strain Gauges, Resistance thermometer, Thermistor, Hot-wire anemometer, Resistance Hygrometer, Photo-resistive sensor.

UNIT- II INDUCTIVE & CAPACITIVE TRANSDUCER

Inductive transducers: - Principle of operation, construction details, characteristics and applications of LVDT, Induction potentiometer, variable reluctance transducer, synchros, microsyn.

Capacitive transducers: - Principle of operation, construction details, characteristics of Capacitive transducers – different types & signal conditioning- Applications:- capacitor microphone, capacitive pressure sensor, proximity sensor.

UNIT III ACTUATORS

Definition, types and selection of Actuators; linear; rotary; Logical and Continuous Actuators, Pneumatic actuator- Electro-Pneumatic actuator; cylinder, rotary actuators, Mechanical actuating system: Hydraulic actuator - Control valves; Construction, Characteristics and Types, Selection criteria.

Electrical actuating systems: Solid-state switches, Solenoids, Electric Motors- Principle of operation and its application: D.C motors - AC motors - Single phase & 3 Phase Induction Motor; Synchronous Motor; Stepper motors - Piezoelectric Actuator.

UNIT IV MICRO SENSORS AND MICRO ACTUATORS

Micro Sensors: Principles and examples, Force and pressure micro sensors, position and speed micro sensors, acceleration micro sensors, chemical sensors, biosensors, temperature micro sensors and flow micro sensors.

Micro Actuators: Actuation principle, shape memory effects-one way, two way and pseudo elasticity. Types of micro actuators- Electrostatic, Magnetic, Fluidic, Inverse piezo effect, other principles.

UNIT V SENSOR MATERIALS AND PROCESSING TECHNIQUES

Materials for sensors: Silicon, Plastics, metals, ceramics, glasses, nano materials

Processing techniques: Vacuum deposition, sputtering, chemical vapour deposition, electro plating, photolithography, silicon micro machining, Bulk silicon micro machining, Surface silicon micro machining, LIGA process.

TEXT BOOKS

1. Patranabis.D, “Sensors and Transducers”, Wheeler publisher, 1994.
2. Sergej Fatikow and Ulrich Rembold, “Microsystem Technology and Microbotics”, First edition, Springer –Verlag NEwYork, Inc, 1997.
3. Jacob Fraden, “Hand Book of Modern Sensors: Physics, Designs and Application” Fourth edition, Springer, 2010.

REFERENCE BOOKS

1. Robert H Bishop, “The Mechatronics Hand Book”, CRC Press, 2002.
2. Thomas. G. Bekwith and Lewis Buck.N, Mechanical Measurements, Oxford and IBH publishing Co. Pvt. Ltd.,
3. Massood Tabib and Azar, “Microactuators Electrical, Magnetic, thermal, optical, mechanical, chemical and smart structures”, First edition, Kluwer academic publishers, Springer, 1997.
4. Manfred Kohl, “Shape Memory Actuators”, first edition, Springer.

UNIT – I SENSORS

Difference between sensor, transmitter and transducer - Primary measuring elements - selection and characteristics: Range; resolution, Sensitivity, error, repeatability, linearity and accuracy, impedance, backlash, Response time, Dead band. Signal transmission - Types of signal: Pneumatic signal; Hydraulic signal; Electronic Signal.

Principle of operation, construction details, characteristics and applications of potentiometer, Proving Rings, Strain Gauges, Resistance thermometer, Thermistor, Hot-wire anemometer, Resistance Hygrometer, Photo-resistive sensor.

THEORY

1. BASICS – MEASUREMENT DEVICES

Measurement devices perform a complete measuring function, from initial detection to final indication. The important aspects of measurement system are

- i) Sensor – Primary sensing element
- ii) Transducer – changes one form of energy to another form energy
- iii) Transmitter – Contains the transducer and produces an amplified, standardized energy signal.

INTRODUCTION – SENSORS

- A device which provides a usable output in response to a specified measurand.
- Sensor is a device that detects and responds to some type of input from the physical environment
- Input could be light, heat, motion, moisture, force, pressure, displacement, etc.
- It produces a proportional output signal (electrical, mechanical, magnetic, etc.).
- Human beings are equipped with 5 different types of sensors.
- Eyes detect light energy, ears detect acoustic energy, a tongue and a nose detect certain chemicals, and skin detects pressures and temperatures. The eyes, ears, tongue, nose, and skin receive these signals then send messages to the brain which outputs a response.
- For example, when you touch a hot plate, it is your brain that tells you it is hot, not your skin.



Fig. 1. Sensors of human beings.

2. THE BASIC BIOLOGICAL SENSING PROCESS

- A stimulus is received at the receptor where the dendrites of the neurons convert the energy of the stimulus into electromechanical impulses in the dendrites of the neurons.
- The action potentials interpreted by the brain to create the corresponding sensory perception

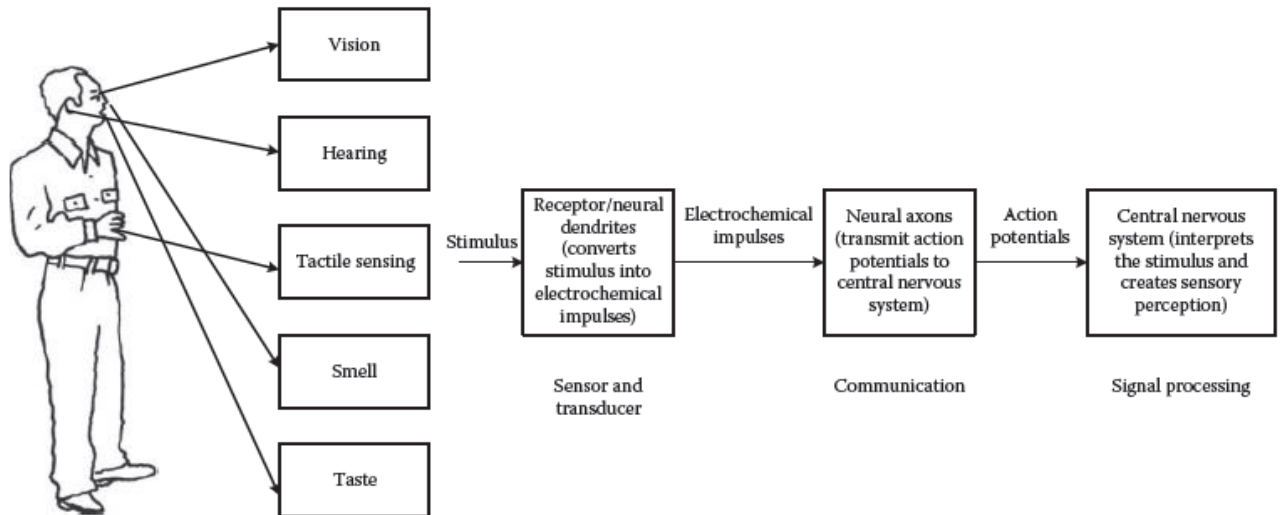

Fig.2. Sensing Process

3. PHYSICAL PRINCIPLES

Amperes's Law

A current carrying conductor in a magnetic field experiences a force (e.g. Galvanometer)

Curie-Weiss Law

There is a transition temperature at which ferromagnetic materials exhibit paramagnetic behaviour

Faraday's Law of Induction

A coil resist a change in magnetic field by generating an opposing voltage/current (e.g. transformer)

Photoconductive Effect

When light strikes certain semiconductor materials, the resistance of the material decreases (e.g. photo resistor)

4. NEED FOR SENSORS

- Sensors are omnipresent. They embedded in our bodies, automobiles, airplanes, cellular telephones, radios, chemical plants, industrial plants and countless other applications.
- Sensors in industrial applications being used for process control, monitoring, and safety, and in medicine being used for diagnostics, There monitoring, critical care, and public health.
- Sensors can improve the world through diagnostics in medical applications; improved performance of energy sources like fuel cells and batteries and solar power; improved health and safety and security for people; sensors for exploring space and improved environmental monitoring.

- Without the use of sensors, there would be no automation!
- We live in the World of Sensors.
- In our day-to-day life we frequently use different types of sensors in several applications
- We can find different types of Sensors in our homes, offices, cars etc. Working to make our lives easier by turning on the lights by detecting our presence, adjusting the room temperature, detect smoke or fire, make us delicious coffee and open garage doors as soon as our car is near the door and many other tasks.

5. CHARACTERISTICS

1. Range

It is the difference between the maximum and minimum value of the sensed parameter. Temperature range of a thermocouple is 25-225°C.

2. Resolution

The smallest change the sensor can differentiate. It is also frequently known as the least count of the sensor. Resolution of an digital sensor is easily determined.

3. Sensitivity

It is the ratio of change in output to a unit change of the input. The sensitivity of digital sensors is closely related to the resolution. The sensitivity of an analog sensor is the slope of the output vs input line, or sensor exhibiting truly linear behaviour has a constant sensitivity over the entire input range.

4. Error

Error is the difference between the result of the measurement and the true value of the quantity being measured. The classification of errors are as follows:

- Bias errors (systematic errors)
- Precision (Random errors)

Bias errors are present in all measurement made with a given sensor and cannot be detected (or) removed by statically means.

5. Accuracy

It is the difference between measured value and true value.

The accuracy defines the closeness between the actual measured value and a true value.

6. Precision

Precision is the ability to reproduce repeatedly with a given accuracy.

7. Repeatability

The ability of a sensor to give same output for repeated applications of same input value.

Repeatability = (maximum – minimum values given) X 100 / full range

8. Impedance

It is the ratio of voltage and current flow for sensor. For a resistive sensor, the impedance Z is same as the resistance R & its unit is ohms.

$$Z = V/I = R$$

9. Response time

Response time is the amount of time required for a sensor to respond completely to a change in input. It describes the speed of change in the output on a step-wise change of the measurand.

10. Linearity

Percentage of deviation from the best fit linear calibration curve

Non-Linearity

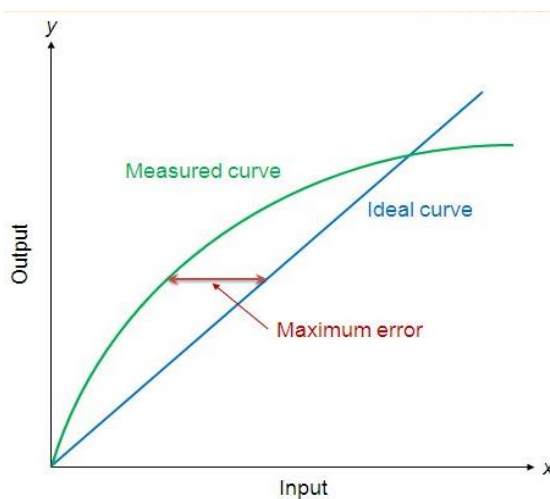

Fig. 3. Non linearity

The nonlinearity indicates the maximum deviation of the actual measured curve of a sensor from the ideal curve.

$$\text{Nonlinearity (\%)} = \text{Maximum deviation in input} / \text{Maximum full scale input}$$

11. Dead band/time

The dead band or dead space of a transducer is the range of input values for which there is no output. The dead time of a sensor device is the time duration from the application of an input until the output begins to respond or change.

12. Backlash

In engineering, backlash, sometimes called lash or play, is a clearance or lost motion in a mechanism caused by gaps between the parts.

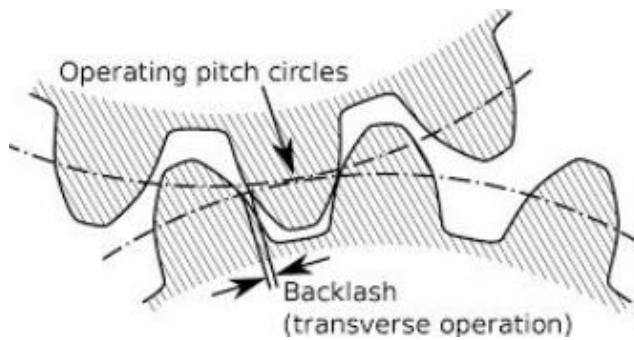

Fig. 4. Backlash

6. SIGNAL TRANSMISSION

- Pneumatic signal – Pneumatic Signal is pressure of a gas (or air) in a pipe, instead of electrical current. It is difficult to control very low pressures accurately with a simple regulator, plus you have to provide vacuum to allow for calibration and measurement hysteresis & repeatability errors.
- Hydraulic signal -Hydraulic signals are self-propagating changes in water (fluid) pressure.
- Electric signal - An electrical signal is a voltage OR current which conveys information, usually it means a voltage.

7. STANDARD SIGNAL TYPES

Most modern equipment works on the following standard signal ranges

- Electric – 4 to 20 mA
- Pneumatic – 0.2 to 1.0 bar (or) 3 to 15 psi
- Digital standards

The advantage of having a standard range is that all equipment is sold readily calibrated. This means that minimum signal (temperature, speed, force, pressure and so on)is represented by 4 mA or 0.2 bar and the maximum signal is represented by 20 mA or 1.0 bar.

8. HYDRAULIC SIGNAL TRANSMISSION SYSTEM

- The hydraulic systems consists a number of parts which include storage tank, filter, hydraulic pump, pressure regulator, control valve, hydraulic cylinder, piston and leak proof fluid flow pipelines.
- The output shaft with piston transfers the motion or force however all other parts help to control the system.

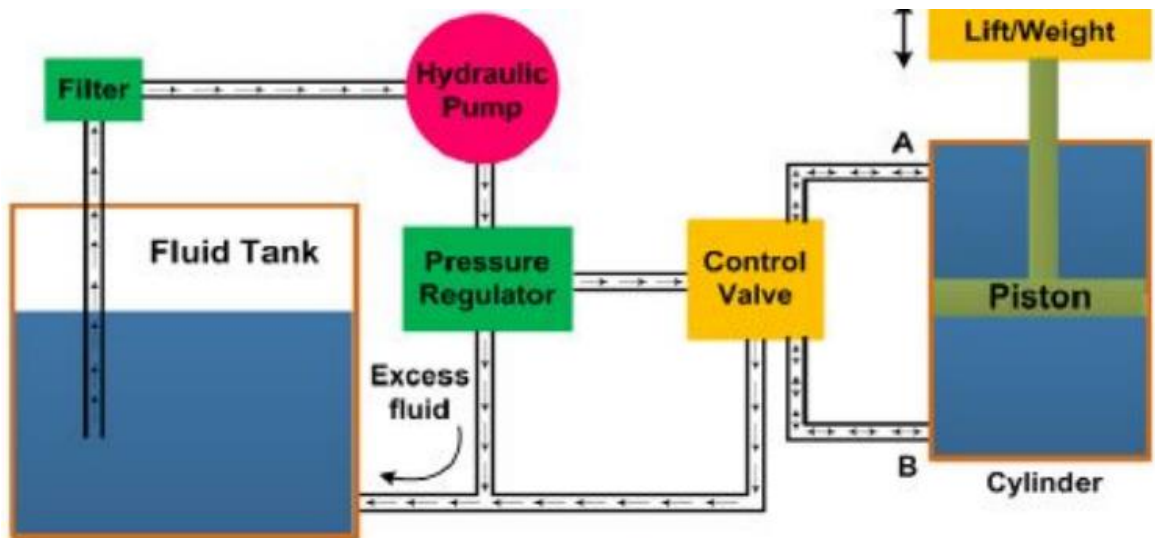

Fig.5. Schematic of Hydraulic system

- The storage/fluid tank is a reservoir for the liquid used as a transmission media.
- The liquid used is generally high density incompressible oil.
- It is filtered to remove dust and the pump delivers constant volume in each revolution of the pump shaft
- The movement of piston is controlled by changing liquid flow from port A and port B.
- The cylinder movement is controlled by using control valve which directs the fluid flow.
- The fluid pressure line is connected to the port B to raise the piston and it is connected to port A to lower down the piston.
- The valve can also stop the fluid flow in any of the port.
- The leak proof piping is also important due to safety, environmental hazards and economical aspects.

Hydraulic System

Pneumatics use an easily compressible gas such as air or other sorts of suitable pure gas—while hydraulics uses relatively incompressible liquid media such as hydraulic or mineral oil, ethylene glycol, water, or high temperature fire-resistant fluids.

Examples of Hydraulic System

- Hydraulic Lifts - Hydraulic lifts are used for moving goods or people vertically.
- Hydraulic Brakes - Braking system of the vehicle is an important example of hydraulics.
- Hydraulic Steering.
- Hydraulic Jacks.
- Heavy Equipment
- Airplanes.
- Hydraulic Shock Absorbers

9. PNEUMATIC SIGNAL TRANSMISSION SYSTEM

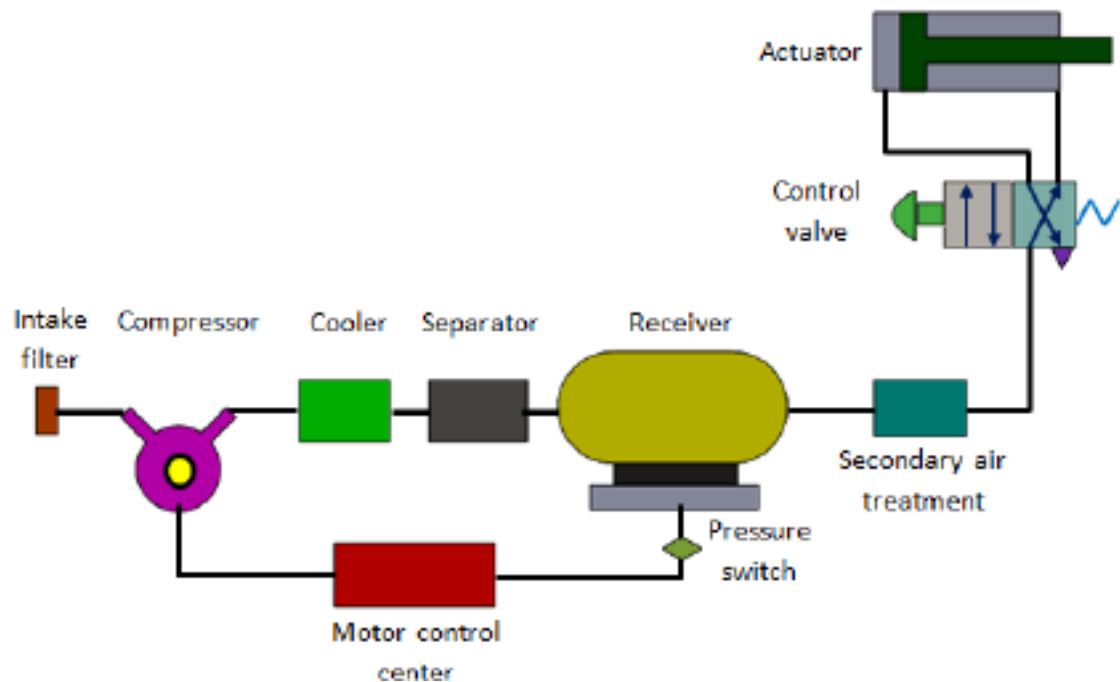

Fig. 6. Schematic of Pneumatic system

PNEUMATIC SYSTEM

- Pneumatics deals with application of compressed air in our daily life in general and manufacturing automation in particular.
- Pneumatic systems use air as the medium which is abundantly available and can be exhausted into the atmosphere after completion of the assigned task.
- Important components of a pneumatic system:
- **Air filters:** These are used to filter out the contaminants from the air.
- **Compressor:** Compressed air is generated by using air compressors. Air compressors are either diesel or electrically operated. Based on the requirement of compressed air, suitable capacity compressors may be used.
- **Air cooler:** During compression operation, air temperature increases. Therefore coolers are used to reduce the temperature of the compressed air.
- **Dryer:** The water vapour or moisture in the air is separated from the air by using a dryer.
- **Control Valves:** Control valves are used to regulate, control and monitor for control of direction flow, pressure etc.
- **Air Actuator:** Air cylinders and motors are used to obtain the required movements of mechanical elements of pneumatic system.
- **Electric Motor:** Transforms electrical energy into mechanical energy. It is used to drive the compressor
- **Receiver tank:** The compressed air coming from the compressor is stored in the air Receiver.

10. COMPARISONS OF ELECTRICAL, HYDRAULIC & PNEUMATIC SYSTEM

	<i>Electrical</i>	<i>Hydraulic</i>	<i>Pneumatic</i>
<i>Energy source</i>	Usually from outside supplier	Electric motor or diesel driven	Electric motor or diesel driven
<i>Energy storage</i>	Limited (batteries)	Limited (accumulator)	Good (reservoir)
<i>Distribution system</i>	Excellent, with minimal loss	Limited basically a local facility	Good. can be treated as a plant wide service
<i>Energy cost</i>	Lowest	Medium	Highest
<i>Rotary actuators</i>	AC & DC motors. Good control on DC motors. AC motors cheap	Low speed. Good control. Can be stalled	Wide speed range. Accurate speed control difficult
<i>Linear actuator</i>	Short motion via solenoid. Otherwise via mechanical conversion	Cylinders. Very high force	Cylinders. Medium force
<i>Controllable force</i>	Possible with solenoid & DC motors Complicated by need for cooling	Controllable high force	Controllable medium force
<i>Points to note</i>	Danger from electric shock	Leakage dangerous and unsightly. Fire hazard	Noise

11. PRIMARY MEASURING ELEMENTS

- Most Pressure Sensitive primary measuring devices use elastic members at the primary stage for sensing of pressure.
- These elastic members are of many types and convert the pressure into displacement.
- They are known as Force Summing Devices,
- They are :
 1. Bourdon tubes
 2. Diaphragms
 3. Bellows

12. BOURDON TUBES

The fluid whose pressure is to be measured is made to press the pressure sensitive element and since the element is an elastic member, it deflects and the deflection is proportional to the applied pressure.

- One end of the tube is sealed
- The other end is open for the fluid to enter
- When the fluid whose pressure is to be measured enters the tube. The tube tends to straighten out on account of the pressure.
- This causes the movement of the free end which is measured.
- Bourdon tubes measure gauge pressure
- The materials used are brass, phosphor bronze, beryllium copper, and steel.

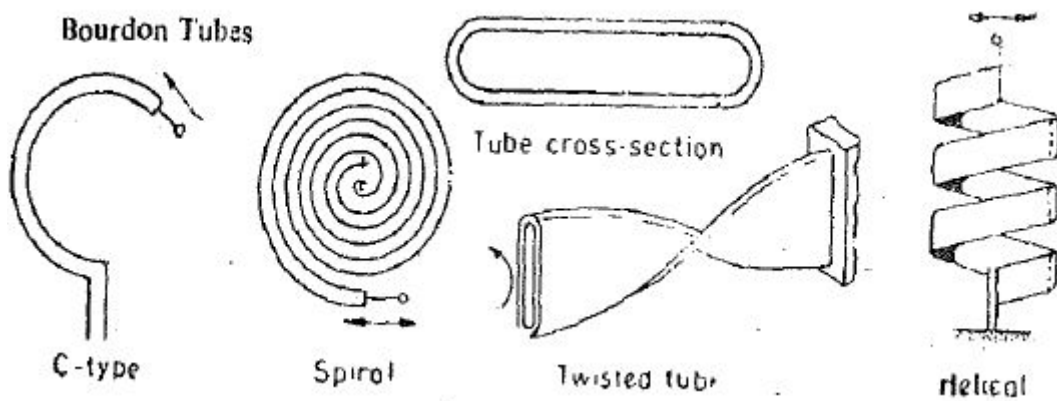

Fig. 7. Types of Bourdon tubes

13. DIAPHRAGM

- The movement of a diaphragm is a convenient way of sensing a pressure.
- The unknown pressure is applied to one side of the diaphragm.
- The edge of the diaphragm is rigidly fixed and this causes a deflection.
- The displacement of the centre of the diaphragm may be measured to know the value of the pressure, because the deflection is directly proportional to the pressure.
- In order to obtain larger deflections, two corrugated diaphragms may be welded, brazed or soldered to form a Capsule.
- The diaphragms are usually made of mild steel.

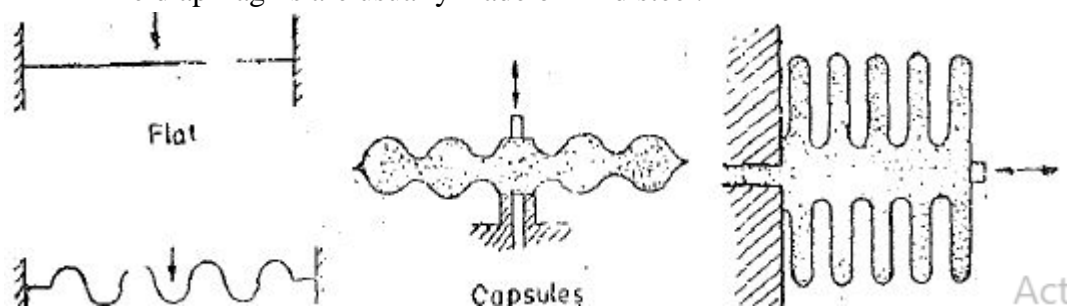

Fig.8. Types of Diaphragms

14. BELLOWS

- Bellows is a thin walled tube approximately (0.1 mm thick) having a corrugated shape.
- It is made from a single piece of metal, usually special brass or stainless steel.
- Bellows is essentially a pressure activated spring.
- The displacement of the Bellows for a particular pressure depends upon the type and the thickness of the material used
- The most commonly used materials for bellows and other pressure sensing elements are steel, phosphor bronze and beryllium copper

15. APPLICATIONS OF SENSORS

Sensors are used in many industrial and home appliances :

- Wireless Sensor Network
- Water level Indicator
- Laser Security Alarm
- Firing Alarm sensor
- Automatic braking & Speed Control Mechanism
- Smart Phone Touch Screen
- Railway Gate Control Mechanism
- Fully Automation Control System, etc.,

16. DRAWBACKS OF SENSORS

Some of the drawbacks occur in sensors while it is in working condition:

- Life time becomes less due to over usages
- Easily affected by external source such as noise, magnetic interference, etc.,
- Due to noise and any other interference, low stability & sensitivity may leads to system failure.
- Some sensor may face complexity while contact with some physical quantities.
- More expensive in RTD sensor than Thermocouples.

17. SOME EXAMPLES OF SENSORS

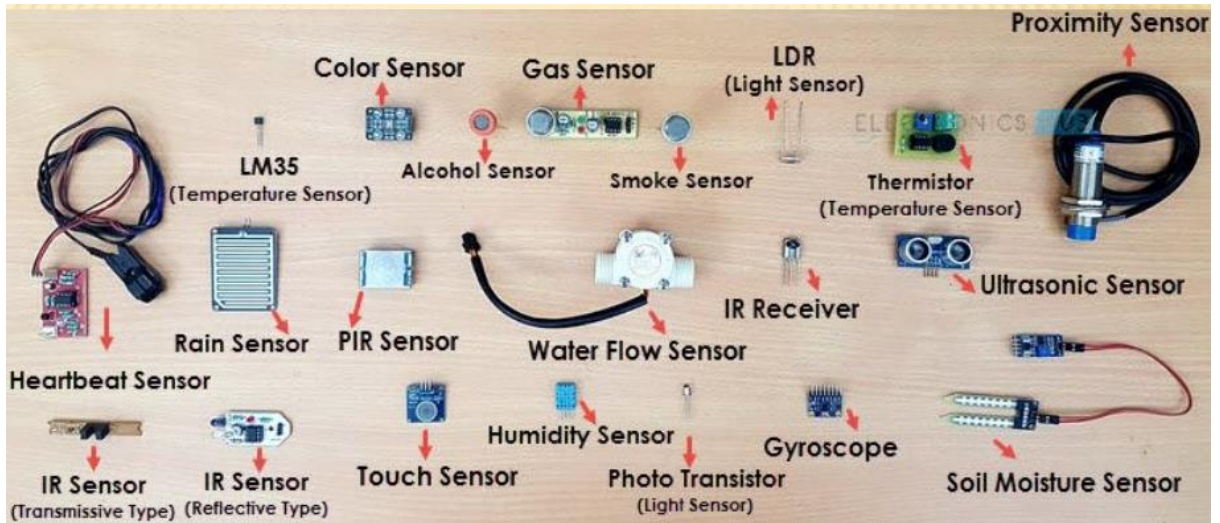

Fig.9. Examples of sensors

18. RESISTIVE SENSORS

PRINCIPLE OF RESISTIVE SENSORS

- A resistive sensor is a electromechanical device that converts a mechanical change such as displacement into an electrical signal that can be monitored.
- Resistance = (Resistivity * Length)/Area; $R = \rho L / A$
- The resistance of a material depends on four factors:
 - Composition
 - Temperature
 - Length
 - Cross Sectional Area
 - Changes in composition and temperature do not change the resistivity of a material in such a simple way.
- Major types of Resistive sensors
 - Potentiometers
 - Strain Gauges
 - Resistance temperature detector(RTD)
 - Thermistors
 - Light Dependent Resistor (LDR)

19. POTENTIOMETER

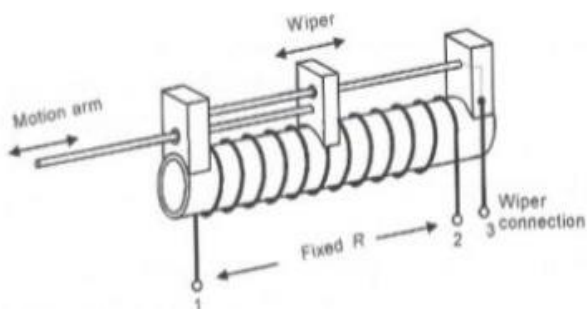

Fig.10. Potentiometric displacement sensor

The object of whose displacement is to be measured is connected to the slider by using

- a rotating shaft (for angular displacement)
- a moving rod (for linear displacement)
- a cable that is kept stretched during operation

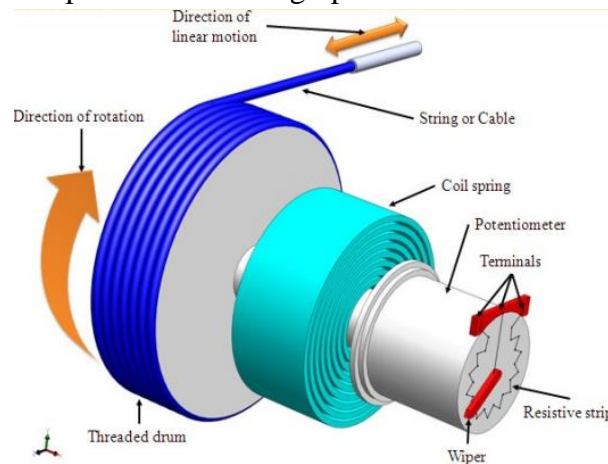

Fig.11. Schematic of a rotary type potentiometer sensor for measurement of linear displacement

POTENTIOMETER: ELECTRIC CIRCUIT

- $V_A = I R_A$ (1)
- But $I = V_S / (R_A + R_B)$ (2)
- $V_A = V_S R_A / (R_A + R_B)$ (3)

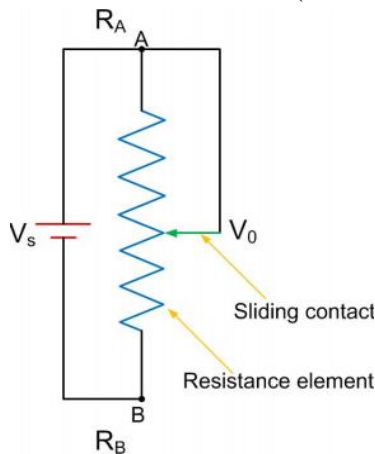

Fig. 12. Electric circuit of the potentiometer

As we know $R = \rho L / A$ where

- ρ is electrical resistivity,
- L is length of resistor and
- A is area of cross section
- $V_A = V_S L_A / (L_A + L_B)$ (4)

ADVANTAGES AND DISADVANTAGES.

Advantages:

- They are inexpensive.
- They are simple to operate

- They are very useful for measurement of large amplitudes of displacement.
- Their electrical efficiency is very high
- It should be understood that while the frequency response of wire wound potentiometers is limited, the other types of potentiometers are free from this problem.
- In wire wound potentiometers the resolution is limited while in Cermet and metal film potentiometers, the resolution is infinite.

Disadvantages:

Using a linear potentiometer requires a large force to move their sliding contacts (wipers). The other problems with sliding contacts are that they can be contaminated, can wear out, become misaligned and generate noise. So the life of limited

APPLICATIONS

These sensors are primarily used in the control systems with a feedback loop to ensure that the moving member or component reaches its commanded position. used on machine-tool controls, elevators, liquid-level assemblies, forklift trucks, automobile throttle controls In manufacturing, these are used in control of injection molding machines, woodworking machinery, printing, spraying, robotics, etc. used in computer-controlled monitoring of sports equipment.

20. PROVING RINGS

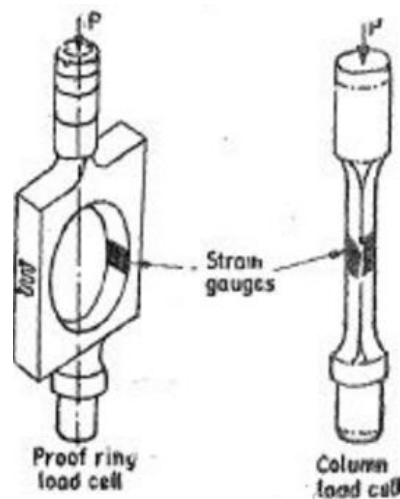

Fig. 13. Proving rings

- They are used for measurement of force, weight or load.
- The applied force causes a deflection which is measured with the help of electrical sensors.
- For measurement of displacement LVDT is to attach between the top and bottom of the proving.

When the force is applied, the relative displacement can be measured. An LVDT is normally used for measurement of deflection which is of the order of I mm or so. Another method is to use strain gauges for measurement of strain in a ring or a column type of element. This is called a Load Cell. Both compressive as well as tensile stresses can be measured with the help of load cells.

21. STRAIN GAUGE – PRINCIPLE

- If a metal conductor is stretched or compressed, its resistance changes on account of the fact that both length and diameter of conductor change.
- Also there is a change in the value of resistivity of the conductor when it is strained and this property is called piezo resistive effect.
- Therefore, resistance strain gauges are also known as piezo resistive gauges.
- The strain gauges are used for measurement of strain and in many detectors notably the load cells, Torque meters, diaphragm type pressure gauges, temperature sensors, accelerometers and flow meters, they employ strain gauges as secondary sensors

Strain:

Strain is the amount of deformation of a body due to an applied force. Strain (ϵ) is defined as the fractional change in length, as shown in Fig. Strain can be positive (tensile) or negative (compressive). In practice, the magnitude of measured strain is very small. Therefore, strain is often expressed as micro strain ($\mu\epsilon$), which is $\epsilon \times 10^{-6}$

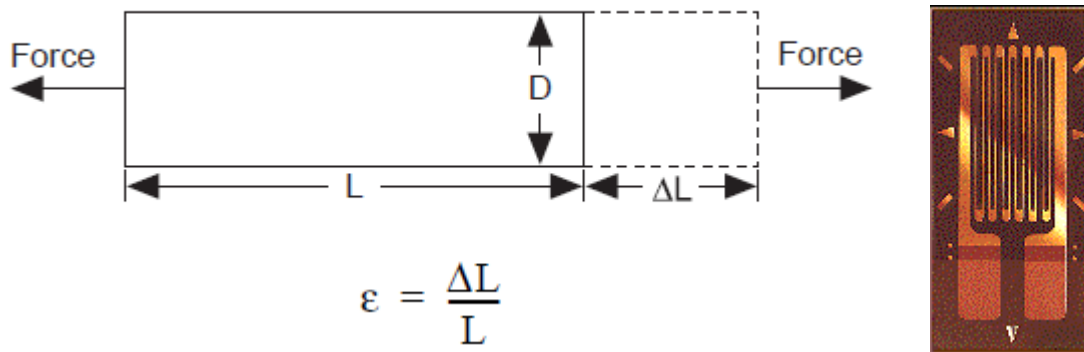

Fig. 14. strain gauge

Strain Gauge

While there are several methods of measuring strain, the most common is with a strain gauge, a device whose electrical resistance varies in proportion to the amount of strain in the device. For example, the piezo resistive strain gauge is a semiconductor device whose resistance varies nonlinearly with strain. The most widely used gauge, however, is the bonded metallic strain gauge. A fundamental parameter of the strain gauge is its sensitivity to strain, expressed quantitatively as the gauge factor (GF).

Gauge factor is defined as the ratio of fractional change in electrical resistance to the fractional change in length (strain):

$$GF = \frac{\Delta R/R}{\Delta L/L} = \frac{\Delta R/R}{\epsilon}$$

The Gauge Factor for metallic strain gauges is typically around 2.

SEMICONDUCTOR STRAIN GAUGE

To have a high sensitivity, a high value of gauge factor is desirable. A high gauge factor means a relatively higher change in resistance which can be easily measured with a good degree of accuracy.

Semiconductor strain gauges are used where a very high gauge factor and a small envelope are required.

The resistance of the semi-conductors changes with change in applied strain.

Unlike in the case of metallic gauges where the change in resistance is mainly due to change in dimensions when strained, the semi-conductor strain gauges depend for the action upon piezoresistive effect i.e. the Change in the value of the resistance due to change in resistivity

Semiconducting materials such as silicon and germanium are used as resistive materials for semi-conductor strain gauges. Using semiconducting wafers or filaments which have a thickness of 0.05 mm and bonding them on a suitable insulating substrates, such as teflon. Gold Leads are used for making the contacts.

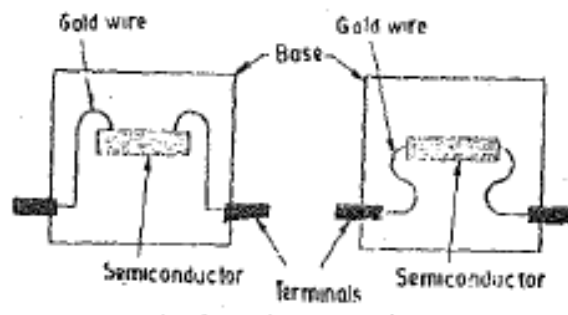

Fig. 15. Semiconductor strain gauge

ADVANTAGES AND DISADVANTAGES

Advantages:

- Semi conductor strain gauges have a high gauge factor. This allows measurement of very small strains of the order of 0.01 micro strain.
- Hysteresis characteristics of semi-conductor strain gauges are excellent
- Fatigue life is in excess of 10×10^6 operations and the frequency response is up to 10 power 12 Hz.
- Semi-conductor strain gauges can be very small ranging in length from 0.7 to 7 mm.

Disadvantages:

- They are very sensitive to changes in temperature

- Linearity of the semi-conductor strain gauges is poor.
- Semi-conductor strain gauges are more expensive and difficult to attach to the object under study.
- To measure small changes in resistance, and compensate for the temperature sensitivity, strain gauges are almost always used in a bridge configuration with a voltage or current excitation source.
- Wheatstone bridge, consists of four resistive arms with an excitation voltage, V_{EX} , that is applied across the bridge

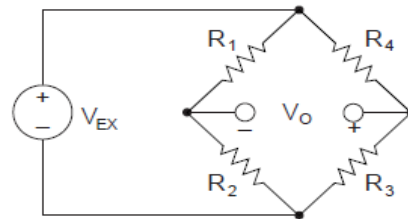

Wheatstone Bridge

$$V_O = \left[\frac{R_3}{R_3 + R_4} - \frac{R_2}{R_1 + R_2} \right] \cdot V_{EX}$$

Fig. 16. Basic Wheatstone bridge

- The sensitivity of the bridge to strain can be doubled by making both gauges active, although in different directions.
- Fig illustrates a bending beam application with one bridge mounted in tension ($R_G + R$) and the other mounted in compression ($R_G - R$).
- The output voltage is linear and approximately doubles the output of the quarter-bridge circuit

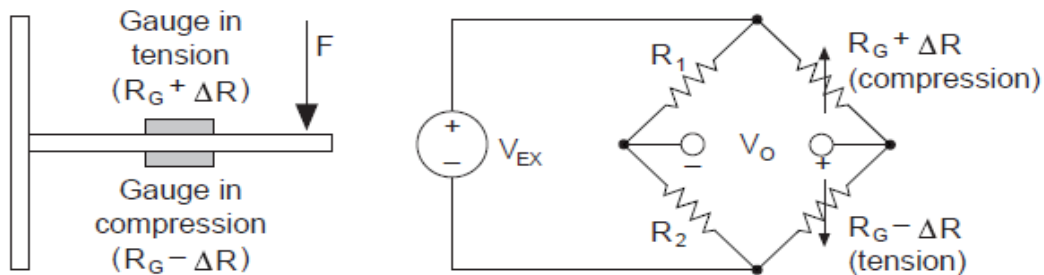

$$\frac{V_O}{V_{EX}} = -\frac{GF \cdot \epsilon}{2}$$

Fig. 17. Half bridge circuit

- It can be further increase the sensitivity of the circuit by making all four of the arms of the bridge active strain gauges, and mounting two gauges in tension and two gauges in compression.
- The equations given here for the Wheatstone bridge circuits assume an initially **balanced bridge that generates zero output when no strain is applied**

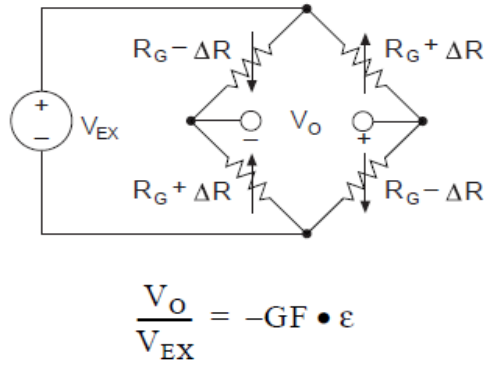

Fig. 18. Full bridge circuit

Uses: The strain gauge has been in use for many years and is the fundamental sensing element for many types of sensors, including pressure sensors, load cells, torque sensors, position sensors, etc

22. RESISTANCE THERMOMETER

- Accurate & Stable
- Reasonably wide temperature range
- More Expensive
- Positive temperature constant
- Requires constant current excitation
- Smaller resistance range
 - Self heating is a concern
 - Lead wire resistance is a concern
- More complicated signal conditioning

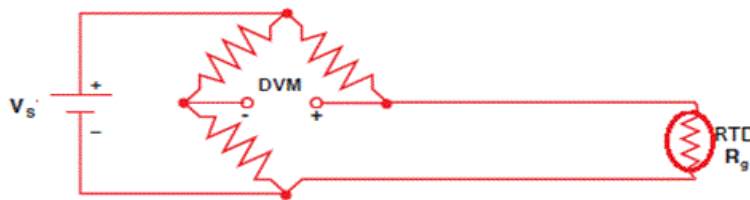

Fig. 19. Two wires RTD bridge

- Temperature Detector (also known as a Resistance Thermometer or RTD) is an electronic device used to determine the temperature by measuring the resistance of an electrical wire.
- The variation of resistance of the metal with the variation of the temperature is given as,

$$R_t = R_0[1 + (t - t_0)]$$

Where, R_t and R_0 are the resistance values at t C and t_0 C temperature

In RTD devices; Copper, Nickel and Platinum are widely used metals. Platinum has the temperature range of 650oC, and then the Copper and Nickel have 120oC and 300oC respectively.

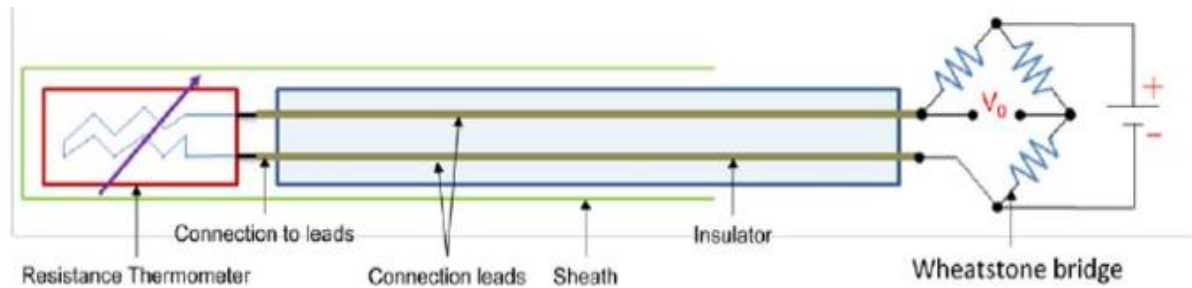

Fig. 20. Construction of Resistance Temperature Detector

These three metals are having different resistance variations with respect to the temperature variations. Resistance increases with increases with temperature (+ slope)

$$R_T = R_0(1 + \alpha)(T - T_0)$$

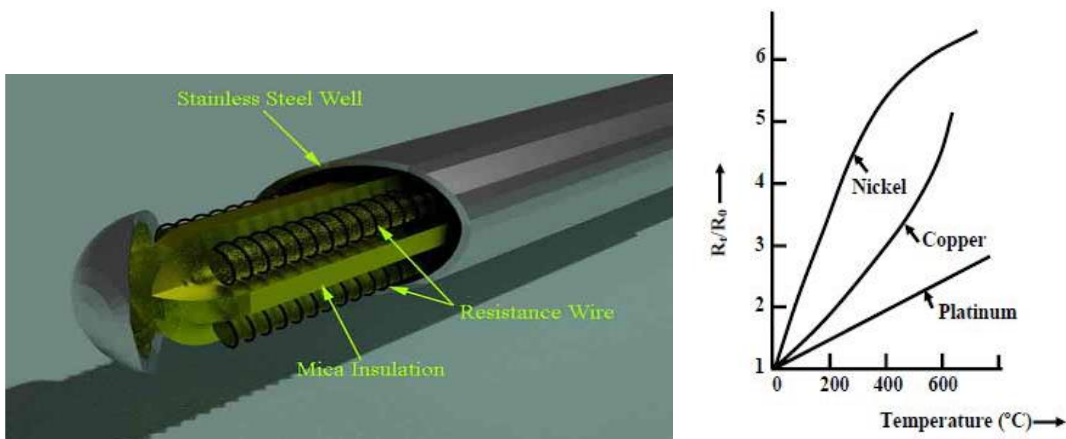

Fig. 21. a) RTD b) waveform

23. THERMISTOR

Thermistors are temperature sensitive semiconductors that exhibit a large change in resistance over a relatively small range of temperature. There are two main types of thermistors, positive temperature coefficient (PTC) and negative temperature coefficient (NTC). The resistance of a thermistor at room temperature may decrease as much as 5 percent for each 1°C rise in temperature. This high sensitivity to temperature changes make the thermistors extremely useful for precision temperature measurements, control and compensation. Thermistors are widely used in such applications especially in the temperature range of -60°C to +15°C. The resistance of thermistors ranges from 0.5 ohm to 0.75 Meg ohm. Thermistors are composed of sintered mixture of metallic oxides such as manganese,

nickel, cobalt, copper, iron and uranium. They are available in variety of sizes and shapes. The thermistors may be in the form of beads, rods or discs

Construction and Types

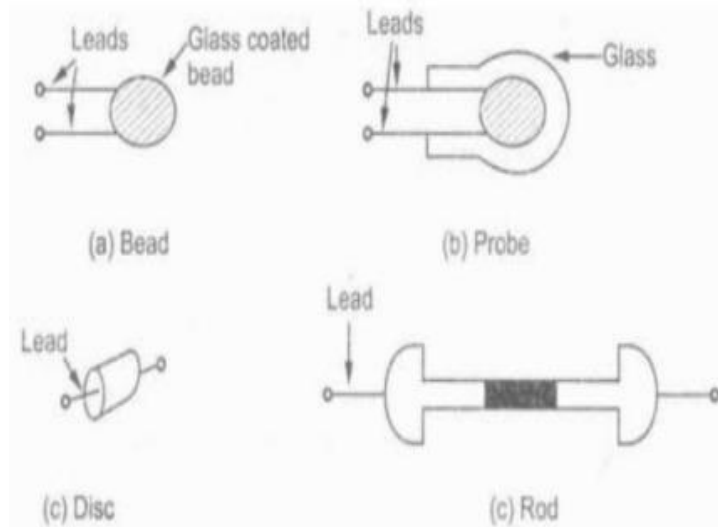

Fig.22. Types of thermistors

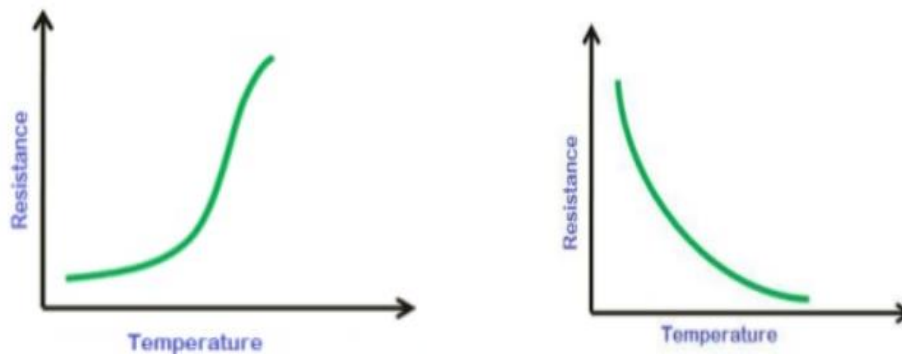

Fig. 23.a) PTC Thermistor

b) NTC Thermistor

$$R_{T_1} = R_{T_2} \exp. \left[\beta \left(\frac{1}{T_1} - \frac{1}{T_2} \right) \right]$$

R_{T_1} = resistance of the thermistor at absolute temperature T_1 ; K,

R_{T_2} = resistance of the thermistor at absolute temperature T_2 ; K,

β = a constant depending upon the material of thermistor, typically 3500 to 4500 K.

ADVANTAGES & DISADVANTAGES

Advantages

- Low cost.
- It produces more accurate output and fast.
- It is suitable for the usage in remote location.
- It can be manufactured in almost any shape and size.
- A high degree of accuracy.

- Good stability and repeatability.
- It has the ability to withstand mechanical and electrical stresses.

Disadvantages

- It produces highly non-linear output.
- It has a limited measuring range.
- Self-heating may occur.
- An external power supply is required.
- It is fragile in nature.
- Shielded cables should be used to minimize interference

APPLICATIONS OF THERMISTORS

- Thermistors are used in an automotive applications
- Instrumentation and Communication
- Consumer electronics
- Food handling and processing
- Industrial electronics
- Medical electronics
- Military and aerospace

PTC Thermistor

- Current limiting devices
- Timer in degaussing coil
- Motors
- Self Regulating heaters

NTC Thermistor

- Very low temperature thermometers
- Digital Thermostats
- In-rush protection devices
- Battery pack monitors

24. Hot wire anemometer

PRINCIPLE: The Hot Wire Anemometer is a device used for measuring the velocity and direction of the fluid. This can be done by measuring the heat loss of the wire which is placed in the fluid stream. The wire is heated by electrical current. The hot wire when placed in the stream of the fluid, in that case, the heat is transferred from wire to fluid, and hence the temperature of wire reduces. The resistance of wire measures the flow rate of the fluid.

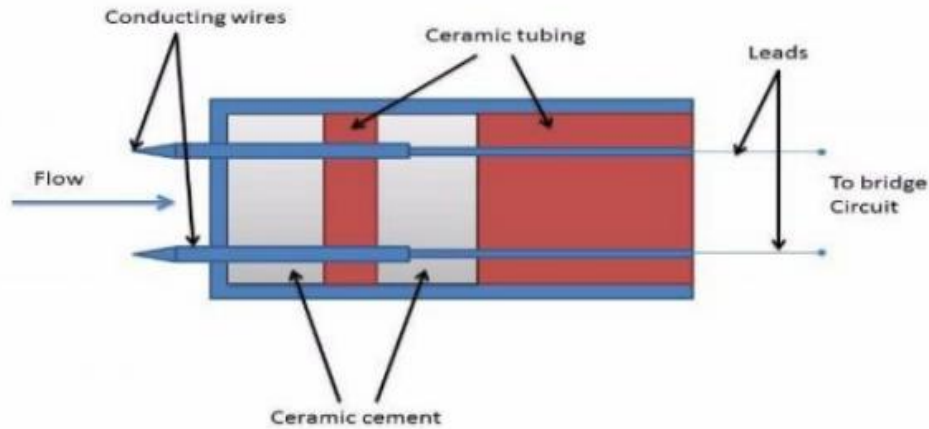

Fig. 24. Hot Wire Anemometer

Construction

The two main parts: 1. Conducting wire 2. Wheat stone bridge.

The conducting wire is housed inside the ceramic body. The wires are taking out from the ceramic body and connecting to the Wheatstone bridge. The wheat stone bridge measures the variation of resistance.

CONSTANT CURRENT METHOD

The anemometer is placed in the stream of the fluid. The current of constant magnitude is passed through the wire. The Wheatstone bridge is also kept on the constant voltage.

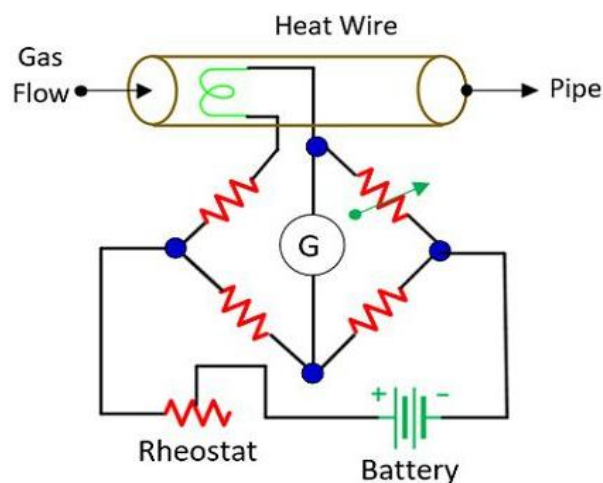

Fig. 25. Constant current method

When the wire is kept in the stream of liquid, in that case, the heat is transferred from the wire to the fluid. The heat is directly proportional to the resistance of the wire. If heat reduces, that means the resistance of wire also reduces. The Wheatstone bridge measures the variation in resistance which is equal to the flow rate of the liquid.

CONSTANT TEMPERATURE METHOD

The wire is heated by the electric current. The hot wire when placed in the fluid stream, the heat transfer from wire to the fluid. Thus, the temperature of the wire changes which also changes their resistance. This circuit works on the principle that the temperature of the wire remains constant. The total current requires to bring the wire in the initial condition is equal to the flow rate of the gas.

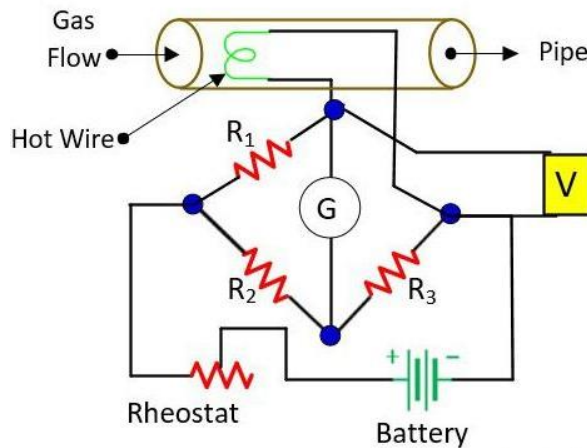

Fig. 26. Constant temperature method

Measurement of the Rate of a Fluid Using a Hot Wire Instrument

In this, the heat transferred electrically to the wire which is placed in the fluid stream. The Wheatstone bridge is used for measuring the temperature of wire regarding their resistance. The temperature of the wire remains constant for measuring the heating current. Thus, the bridge remains balanced. The standard resistor is connected in series with the heating wire. The current through the wire is determined by knowing the voltage drop across the resistor (potentiometer).

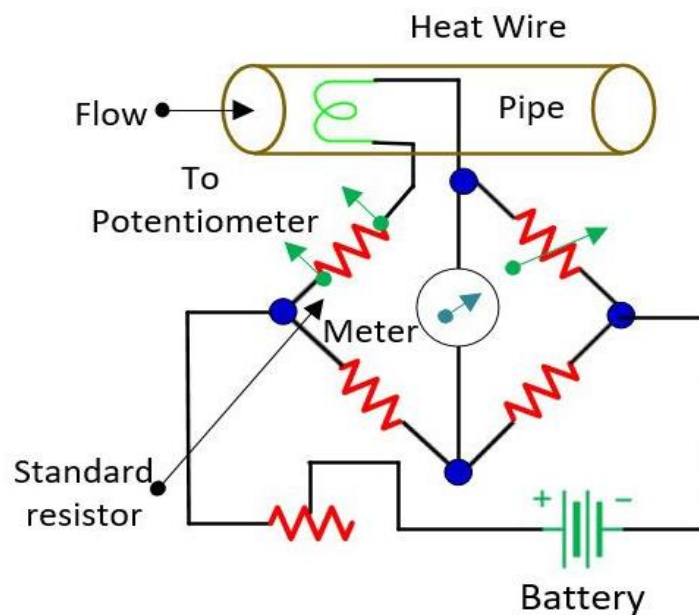

Fig. 27. Measurement of fluid flow

The equation for the heat loss from the heated wire

$$= a(vp + b)^{1/2} \text{ J/s}$$

Where,

- v – velocity of heat flow,
- ρ – the density of fluid, &
- a and b are the constants.

Suppose I , is the current of the wire and the R is their resistance.

$$I^2 R = a(vp + b)^{1/2}$$

$$v = \frac{(I^4 R^2 / a^2 - b)}{\rho}$$

In equilibrium condition,

Heat generated = Heat Lost

Thus if the resistance and temperature of the wire are kept constant, the rate of the fluid flow can be measured by measuring the current I , through the heater wire.

25. RESISTANCE HYGROMETER

Definition:

Hygrometer measures directly the value of humidity present in the surrounding environment. The output is used to indicate relative humidity. The term humidity means the amount of water vapour present in the gas. Several materials exhibit changes in electrical properties that are caused by humidity. The physical properties of the material change by the effect of the humidity and this principle is used in hygrometer for measurement.

The humidity is classified into two types.

- Absolute Humidity
- Relative Humidity

The absolute humidity shows the amount of water vapour presents per unit volume. And the relative humidity is the ratio of the actual water vapour pressure to the maximum water vapour pressure reaches in the substance at the particular temperature. The relative humidity depends on the temperature.

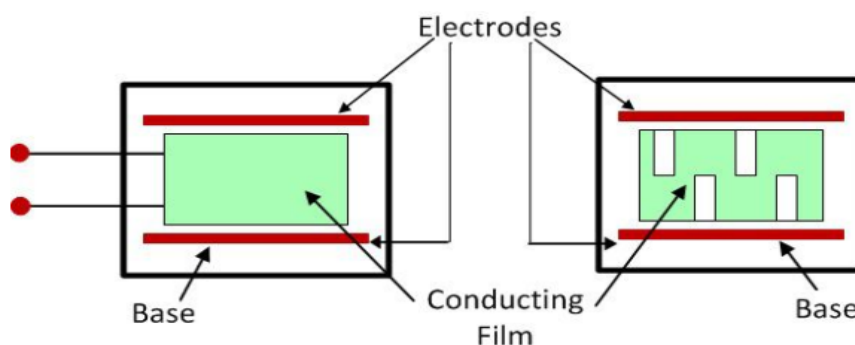

Fig. 28. Hygrometer

The conducting film is made by the lithium chloride and the carbon and placed between the metal electrodes. The resistance of the conducting film varies with the change in the value of humidity present in the surrounding air. The moisture absorbs by the lithium chloride will depend on the relative humidity. If the relative humidity is high, the lithium chloride will absorb more moisture and their resistance decreases. The change in the value of resistance is measured by applying the alternating current to the bridge. The direct current is not used in the bridge as they breakdowns the layer of lithium chloride into its lithium and chlorine atoms. The flow of current measures the value of resistance or the value of relative humidity.

26. PHOTO RESISTIVE SENSOR

A photo resistor is also called a light-dependent resistor (LDR), photoconductor, or photocell since its resistance changes as incident light intensity changes. Materials used as the semiconductor substrate include, lead sulphide (PbS), lead selenide (PbSe), indium antimonide (InSb) which detect light in the infra-red range with the most commonly used of all photo resistive light sensors being Cadmium Sulphide (Cds). Cds is used because its spectral response curve closely matches that of the human eye and can be controlled using a simple torch as a light source. It has a peak sensitivity wavelength (λ_p) of about 560nm to 600nm in the visible spectral range.

LDR characteristics & symbol

The resistance of the cell when unilluminated (dark resistance) is very high at about 10M Ω s which falls to about 100 Ω s when fully illuminated (light resistance).

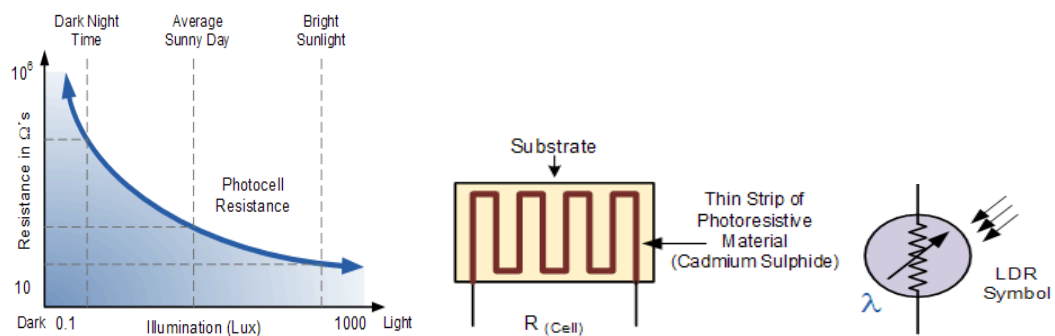

Fig.29. LDR characteristics and symbol

LDR in a circuit

To increase the dark resistance and to reduce the dark current, the resistive path forms a zigzag pattern across the ceramic substrate. The amount of voltage drop across series resistor, R2 is determined by the resistive value of the light dependant resistor, R. The current through a series circuit is common and as the LDR changes its resistive value due to the light intensity, the voltage present at VOUT will be determined by the voltage divider formula. R of the LDR can vary from about 100 Ω in the sun light, to 10M Ω in darkness with this variation of resistance being converted into a voltage variation at VOUT as shown in figure

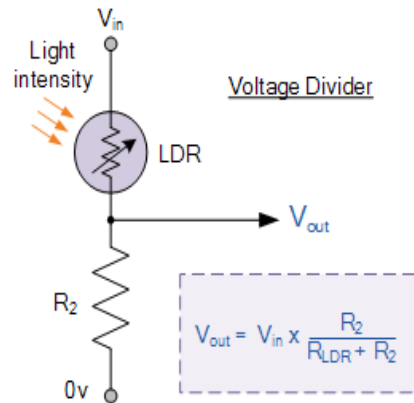

Fig.30. Application of LDR



Fig.31. Examples of LDR

ADVANTAGES & APPLICATIONS

Advantages: Photo resistors are generally low cost, small size, fast response, high sensitivity, and ease of use.

Applications: They are often used in auto dimming, darkness, or twilight detection for turning street lights ON & OFF, and for photographic exposure meters.

MULTIPLE CHOICE QUESTIONS

1. Change in output of sensor with change in input is _____
 - a) Threshold
 - b) Slew rate
 - c) Sensitivity
 - d) None of the mentioned

Answer: c

2. Which of the following can be cause for non-zero output when zero input?
 - a) Bias
 - b) Slew
 - c) Offset
 - d) Offset or bias

Answer: d

3. Smallest change which a sensor can detect is _____

- a) Resolution
- b) Accuracy
- c) Precision
- d) Scale

Answer: a

4. A device that converts one form of energy into other form of energy is called _____

- a) Transmitters
- b) Transducers
- c) Receivers
- d) None of the above

Answer: b

5. Ability to reproduce consistent readings is called _____

- a) Resolution
- b) Accuracy
- c) Precision
- d) Scale

Answer: c

6. Which of the following can be used for measuring temperature?

- a) Metallic diaphragm
- b) Thermometer
- c) Capsule
- d) Bourdon tube

View Answer

Answer: b

7. Other name of RTD is _____

- a) Thermister
- b) Thermocouple
- c) Resistance thermometer
- d) All the above

Answer: c

8. What is PTC thermistor?

- a) Positive temperature coefficient thermistor
- b) Positive transient coefficient thermistor
- c) Pulse transmit coefficient thermistor
- d) All the above

Answer: a

9. Select standard signal range of electrical signals

- a) 4 to 20 MA
- b) 0.2 to 1.0 bar
- c) 3 to 15 psi
- d) All the above

Answer: a

10. Select standard signal range of pneumatic signals

- a) 4 to 20 MA
- b) 5 to 25 psi
- c) 3 to 15 psi
- d) All the above

Answer: c

11. Strain gauge is a _____ device that converts _____ into _____.

- a. Active; electrical signal; change of resistance
- b. Passive; electrical signal; change of resistance
- c. Active; mechanical displacement; change of resistance
- d. Passive; mechanical motion; change of resistance

Answer: d

12. What is humidity sensor?

- a) Hygrometer
- b) Gyroscope
- c) Sesimoscope
- d) Sundial

Answer: a

Assignment

1. Explain the construction, principle of operation, circuit and applications of Strain Gauge with neat diagrams.
2. What are Thermistors? Explain their different forms of construction. Draw their resistivity versus temperature characteristics curve. Describe any one application with neat circuit.

UNIT- II INDUCTIVE & CAPACITIVE TRANSDUCER

Inductive transducers: - Principle of operation, construction details, characteristics and applications of LVDT, Induction potentiometer, variable reluctance transducer, synchros, microsyn.

Capacitive transducers: - Principle of operation, construction details, characteristics of Capacitive transducers – different types & signal conditioning- Applications:- capacitor microphone, capacitive pressure sensor, proximity sensor.

1. INTRODUCTION

Definition:

The transducer is a device which converts one form of energy into another form.

2. Advantages of Electrical Transducer

1. Electrical output can be amplified to any desired level.
2. Low power requirement.
3. Easy transmission.
4. Suitable with digital control.
5. Low cost.
6. Small size.
7. Reduced friction effect.
8. The output can be modified as per requirements of the indicating or controlling equipments.
- 9.

3. CLASSIFICATION – TRANSDUCERS

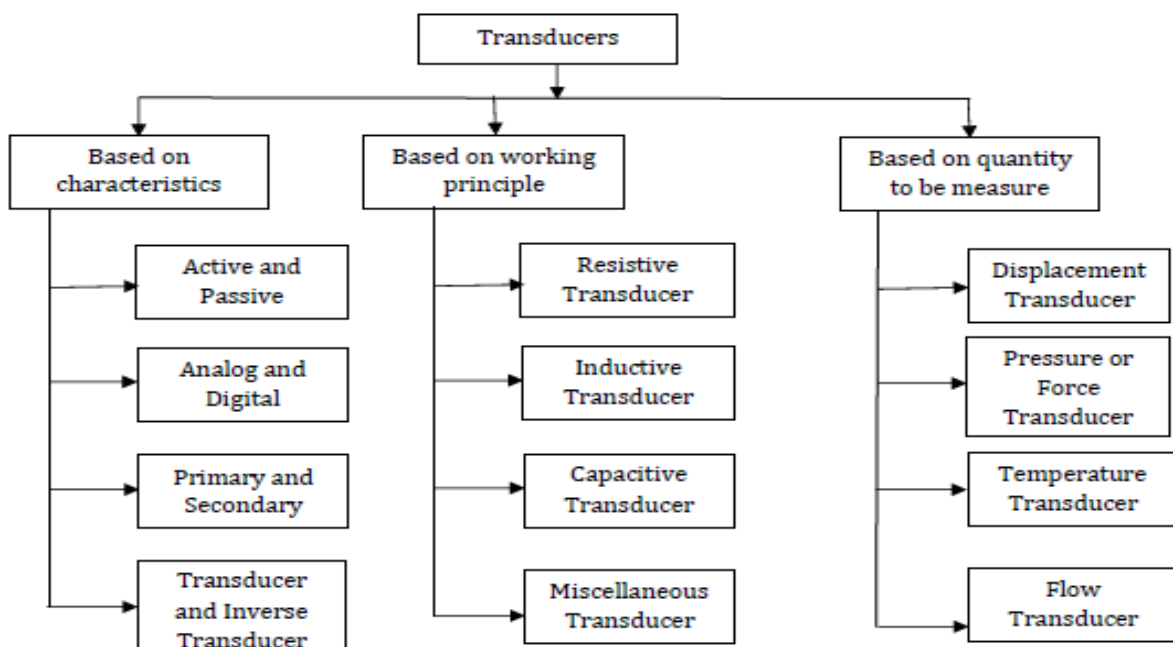

4. Types of transducers

Active Transducer

- ❖ The transducers, which develop their output in form of electrical voltage or current without any auxiliary source are known as active transducers.
- ❖ They draw energy from the system under measurement.
- ❖ They give very small output and use of amplifier is essential.
 - Examples: Tachogenerator, Thermocouple, Piezo-electric crystals, photovoltaic cell etc.

Passive Transducer

- ❖ The transducers in which, the electrical parameters i.e. resistance, inductance and capacitance changes with change in input signal.
- ❖ They require external power source for energy conversion.
- ❖ In this, electrical parameters cause a change in voltage, current or frequency of the external power source.
- ❖ They may draw some energy from the system under measurement.
 - Examples: Resistive, Inductive and Capacitive transducer.

Analog Transducer

- ❖ Analog transducer converts input signal into output signal, which is a continuous function
- ❖ of time.
- ❖ Examples: Thermistor, Strain gauge, LVDT, Thermocouple

Digital Transducer

- ❖ Digital transducer converts input signal into output signal of the form of pulses e.g. it gives discrete output.
- ❖ These transducers are becoming more popular.
- ❖ Sometimes, analog transducer combined with ADC (Analog-to-Digital Converter) is called digital transducer.
- ❖ Examples: Encoders, Hall effect sensors

Primary Transducer

- ❖ When input signal is directly sensed by transducer and physical phenomenon is converted into electrical form directly then such transducer called primary transducer.
 - Examples: Thermistor

Secondary Transducer

- ❖ When input signal is directly sensed first by some sensor and then its output being of some form other than input signal I given as input to a transducer for conversion into electrical form, then it's called secondary transducer.
 - Examples: LVDT for used pressure measurement by using bourdon tube

Transducer (Electrical)

- ❖ It is a device that converts a non-electrical quantity into an electrical quantity.
 - Examples: Thermocouple, Pressure gauge, Strain gauge, Photovoltaic cell

Inverse Transducer

- ❖ It is a device that converts an electrical quantity into non-electrical quantity.
- ❖ It is a precision actuator having an electrical input and low-power non-electrical output.
- ❖ A most useful application of inverse transducer is in feedback measurement systems.
- ❖ Examples: Piezo-electric crystal

5. LVDT

Linear Variable Differential Transformer (LVDT)

- ❖ LVDT is an inductive type passive transducer.
- ❖ It measures force in terms of displacement of ferromagnetic core of a transformer.
- ❖ It converts translational or linear displacement into electrical voltage.
- ❖ It is also known as Linear Variable Differential Transducer.

Principle

- ❖ It is based on the principle of electro-magnetic induction.

Construction

- ❖ LVDT consist of cylindrical transformer where it is surrounded by one primary winding in the centre of the former and two secondary windings at the sides.
- ❖ The numbers of turns in both the secondary windings are equal, but they are opposite to each other.

- ❖ The primary winding is connected to the ac source.
- ❖ A movable soft iron core slides within hollow former and therefore affects magnetic coupling between primary and two secondary.

Operation

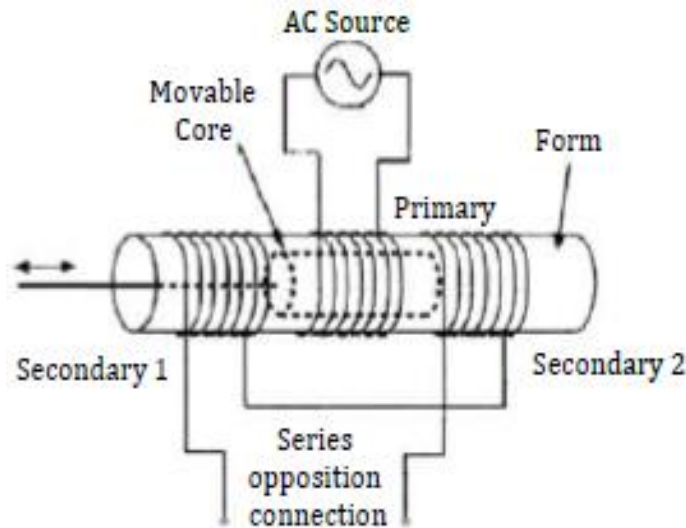

Fig.1. Construction of LVDT

- ❖ When the iron core lies at the centre of both secondary, the output differential voltage remains unaffected and has zero magnitude.
- ❖ When the core moves towards secondary-1, it induces more emf across it and less emf across secondary-2. Let's assume that it is positive displacement.
- ❖ This is due to more flux links with the secondary-1 than secondary-2.
- ❖ When the core moves towards secondary-2, it induces more emf across it and less emf across secondary-1. Let's assume that it is negative displacement.
- ❖ This is due to more flux links with the secondary-2 than secondary-1.
- ❖ The output differential voltage is proportional to the displacement of the iron core.

CIRCUIT OF LVDT

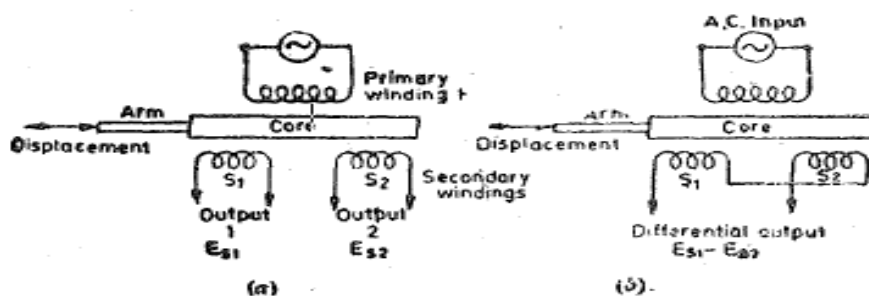

Fig. 2. Circuits of an LVDT

OUTPUT VOLTAGE

Differential output voltage $E_o = E_{s1} - E_{s2}$

When the core is at its normal (NULL) position, the flux linking with both the secondary windings is equal and hence equal emfs are induced in them. Thus at null position $E_{s1} = E_{s2}$. Since the output voltage of the transducer is the difference of the two voltages, the output voltage E_o is zero at null position.

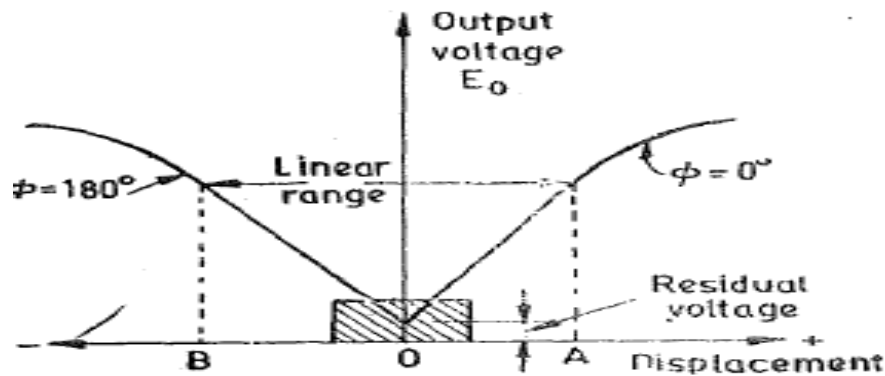

Fig.3. Variation in output voltage with linear displacement for an LVDT

Working

- ❖ Now if the core is moved to the left of the NULL position, more flux links with winding S1 and less with winding S2.
- ❖ Accordingly output voltage E_{s1} , of the secondary winding S1, is more than E_{s2} , the output voltage of secondary winding S2.
- ❖ The magnitude of output voltage is, thus, $E_{s1} - E_{s2}$ and the output voltage is in phase with E_{s1} i.e. the output voltage of secondary winding S1.
- ❖ Similarly, if the core is moved to the right of the null position, the flux linking with winding S2 becomes larger than that linking with winding S1.
- ❖ This results in E_{s2} becoming larger than E_{s1} .
- ❖ The output voltage in this case is $E_o = E_{s2} - E_{s1}$ and is in phase with E_{s2} i.e. the output voltage of secondary winding S2.

Advantages

- ❖ High range (1.25 mm to 250 mm)
- ❖ No frictional losses
- ❖ High input and high sensitivity
- ❖ Low hysteresis
- ❖ Low power consumption
- ❖ Direct conversion to electrical signals

Dis-advantages

- ❖ LVDT is sensitive to stray magnetic fields so they always require a setup to protect them from stray magnetic fields.
- ❖ They are affected by vibrations and temperature.

Applications

- ❖ It is used where displacements ranging from fraction of mm to few cm are to be measured.
- ❖ It act as primary transducer.
- ❖ They can also act as secondary transducer. E.g. the bourdon tube which acts as primary transducer and convert pressure into linear displacement then LVDT converts it into electrical signal.

6. INDUCTIVE TRANSDUCER

Self Inductance

- ❖ Self inductance is the production of emf in a circuit when a magnetic flux linked with the circuit changes as a result of change of current.
- ❖ It works on principle of self inductance
- ❖ Only a single coil is employed.
- ❖ Self induction transducers are usually variable reluctance devices
- ❖ Application: this can be used as displacement sensor, proximity sensor etc.

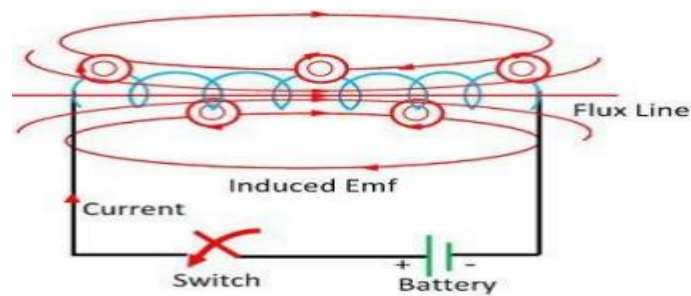

Fig. 4. Self Inductance

Mutual inductance

- ❖ A device specifically designed to produce the effect of mutual inductance between two or more coils is called a transformer.
- ❖ It works on principle of mutual inductance.
- ❖ Two or more number of coils are involved.
- ❖ Applications:
- ❖ LVDT, transformer – step up and step down transformer.

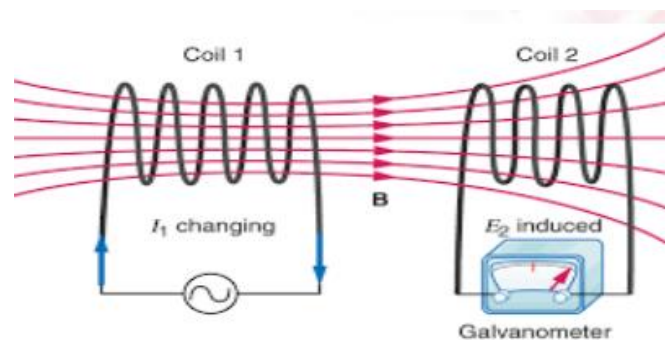

Fig.5. Mutual Inductance

Factors affecting Inductance

Reluctance – Magnetic resistance

The reluctance of a material to the setting up of magnetic flux lines in the material

Unit: Ampere-turns / Weber

$$\mathcal{R} = \frac{l}{\mu A} \quad (\text{At/Wb})$$

Comparing this to the resistance in electric circuit is

$$R = \rho \frac{l}{A} \quad (\text{ohms, } \Omega)$$

$$L = \frac{N^2 \mu A}{l}$$

$$\mu = \mu_r \mu_0$$

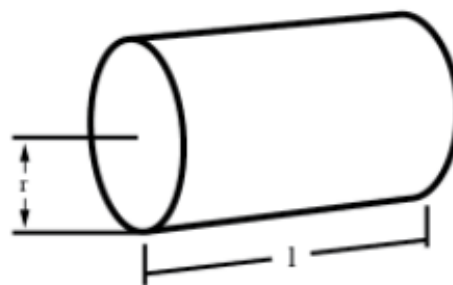

Where,

L = Inductance of coil in Henrys

N = Number of turns in wire coil (straight wire = 1)

μ = Permeability of core material (absolute, not relative)

μ_r = Relative permeability, dimensionless (μ₀ = 1 for air)

μ₀ = 1.26x10⁻⁶ T-m/At permeability of free space

A = Area of coil in square meters = πr²

l = Average length of coil in meters

Fig. 6. Factors affecting Inductance

7. VARIABLE RELUCTANCE SENSORS

- ❖ Reluctance and inductance sound alike but refer to different physical variables.
- ❖ Reluctance is the “opposite” of permeability

$$R = \frac{l}{\mu A}$$

- ❖ where: R - reluctance
- ❖ l - length of magnetic circuit
- ❖ A - cross-sectional area

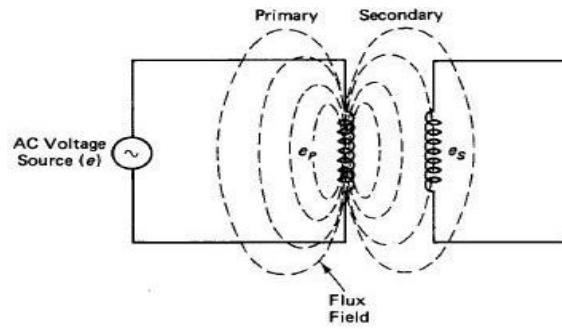

Fig.7. Transformer effect

Variable Reluctance Sensor – [Linear Variable Differential Transformer (LVDT)]

LVDT works on the principle of variation of mutual inductance. There are inductive sensors for measurement of displacement those are based on the principle of variation of self inductance.

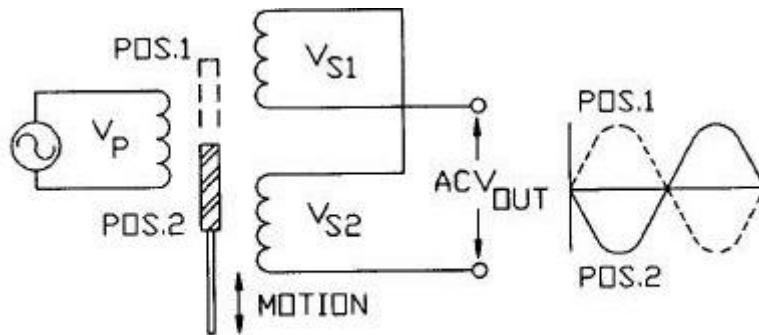

Fig. 8. Working of LVDT

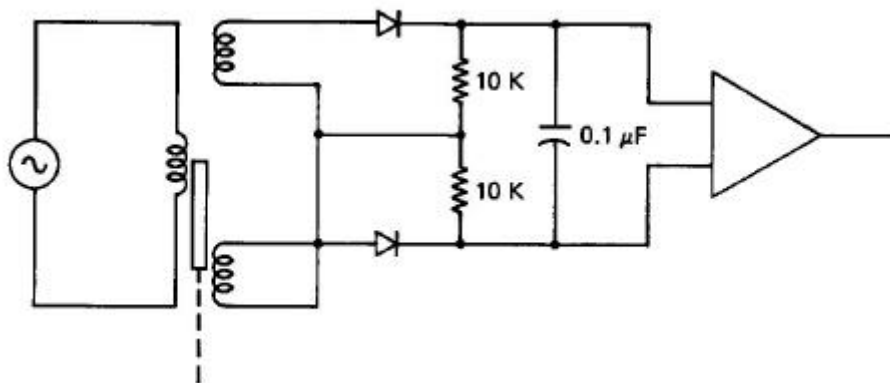

Fig.9. LVDT circuit

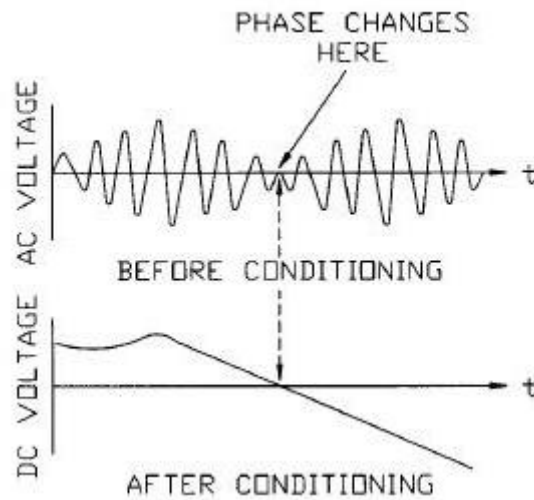

Fig.10. Signal conditioning waveforms.

Linear Variable Differential Transformer (LVDT) – Applications

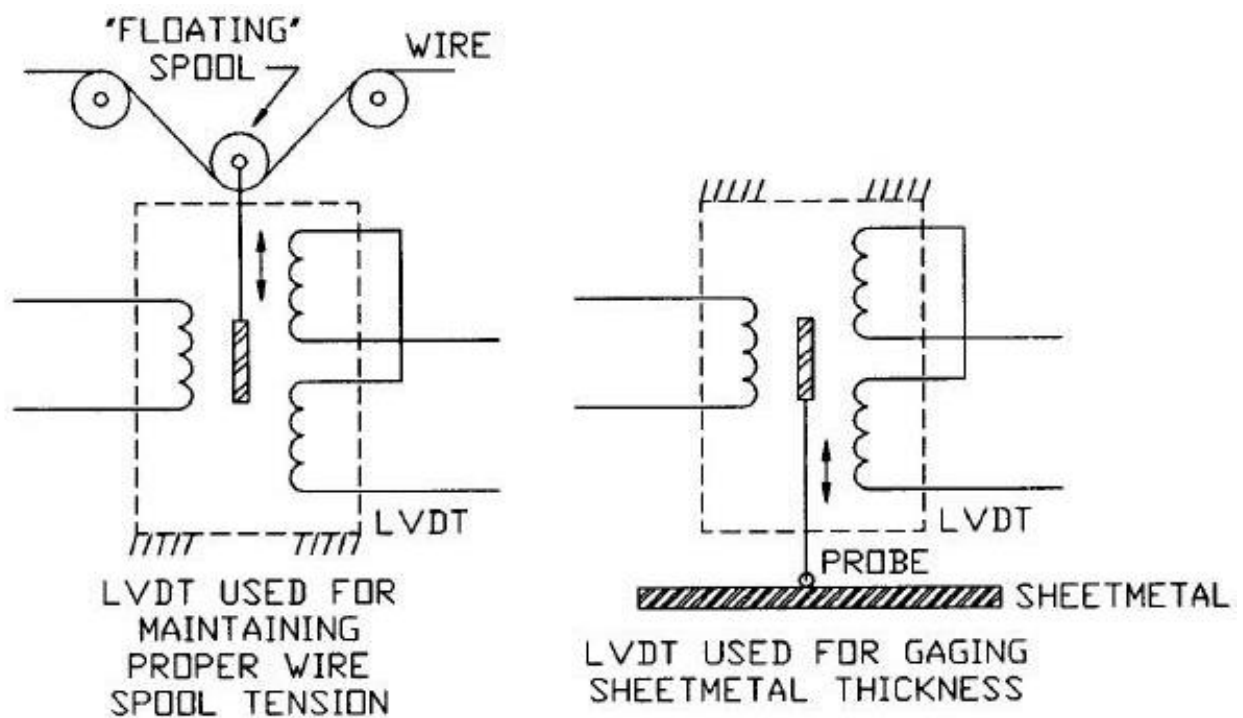

Fig.11. Applications of LVDT

8. Rotary motion LVDT

RVDT

Construction is similar to that of LVDT, except the core is designed in such a way that when it rotates the mutual inductance between the primary and each of the secondary coils changes linearly with the angular displacement.

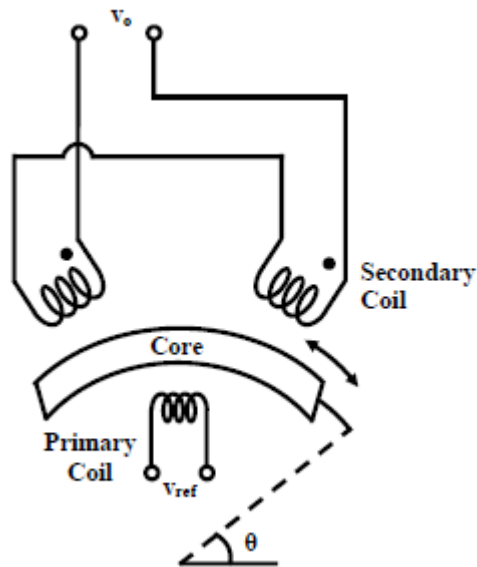

Fig.12. RVDT

9. INDUCTANCE POTENTIOMETER

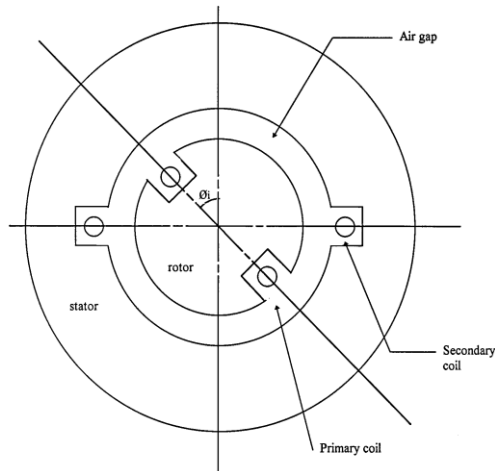

Fig.13. Inductance Potentiometer

- ❖ An induction potentiometer is a linear-variable inductor with two concentrated windings wound on the stator and on the rotor.
- ❖ The rotor winding is excited with ac, inducing voltage in the stator windings.
- ❖ The amplitude of the output voltage is dependent on the mutual inductance between the coils, which is determined by the angle of rotation.
- ❖ For concentrated coils, the variation of the amplitude is sinusoidal, but linearity is restricted in the region of the null position.
- ❖ Different types of induction potentiometers are available with distributed coils that give linear voltages over an angle of 180° of rotation.

- ❖ Standard commercial induction pots operate in a 50 to 400 Hz frequency range. They are small in size, from 1 cm to 6 cm, and their sensitivity can be on the order of 1 V/deg rotation.
- ❖ Although the ranges of induction pots are limited to less than 60° of rotation, it is possible to measure displacements in angles from 0° to full rotation by suitable arrangement of a number of induction pots.
- ❖ As in the case of most inductive sensors, the output of an induction pot may need phase-sensitive demodulators and suitable filters.
- ❖ In many cases, additional dummy coils are used to improve linearity and accuracy.

10. Synchro mechanism - Synchros

- ❖ Control synchros - for indicating readings of position.
- ❖ Torque synchros - for performing work using remotely transmitted signals.

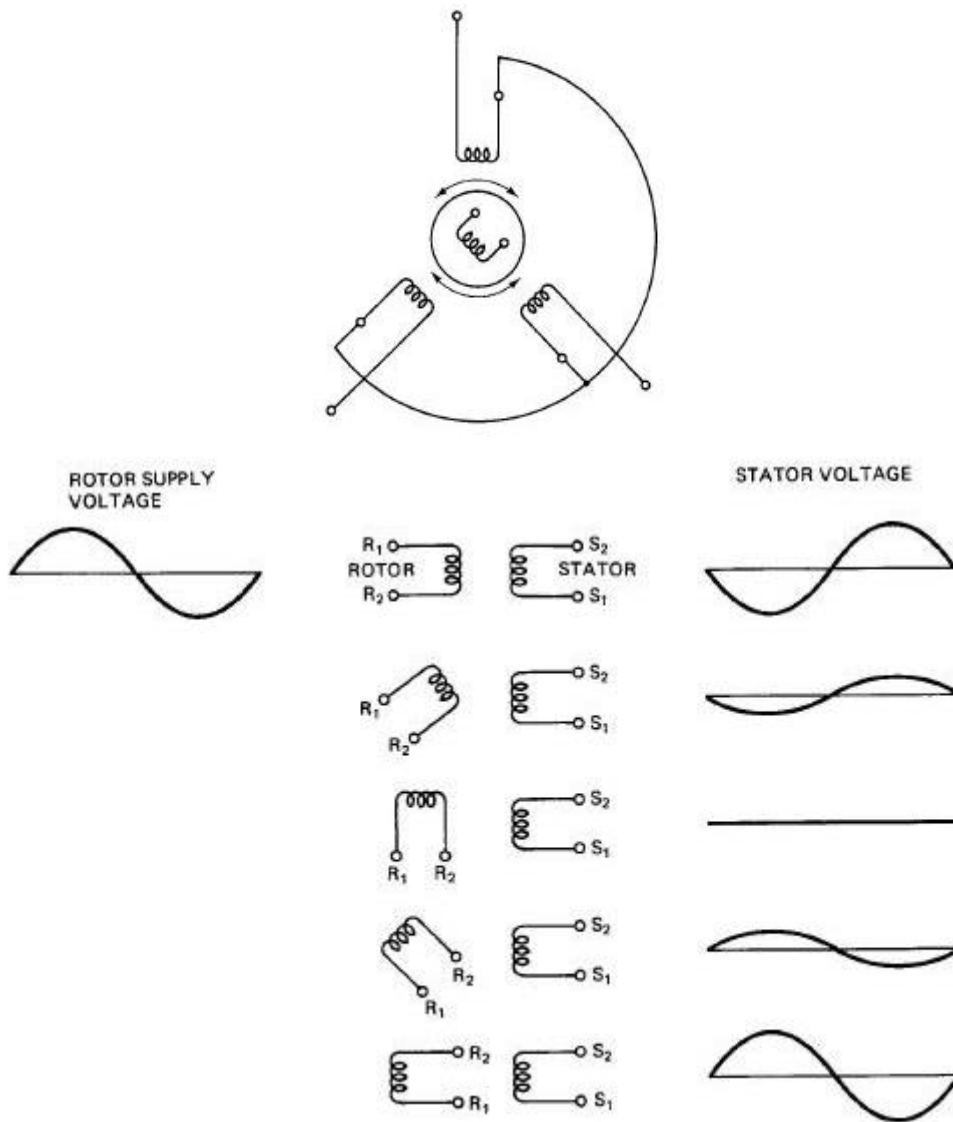

Fig.14. Synchros

- ❖ A synchro is similar to a wound-rotor induction motor.
- ❖ The rotation of the rotor changes the mutual inductance between the rotor coil and the stator coils. The voltages from these coils define the angular position of the rotor.
- ❖ They are primarily used in angle measurements and are commonly applied in control engineering as parts of servomechanisms, machine tools, antennas, etc.
- ❖ Synchros were used in analog positioning systems to provide data and to control the physical position of mechanical devices such as radar antennae, indicator needles on instrumentation, and fire control mechanisms in military equipment.
- ❖ The term “synchro” defines an electromagnetic position transducer that has a set of three phase output windings that are electrically and mechanically spaced by 120° instead of the 90° spacing found in a resolver.
- ❖ In the rotor primary mode, the synchro is excited by a single-phase ac signal on the rotor.
- ❖ As the rotor moves 360° , the three amplitude
- ❖ modulated sine waves on the three phases of the output have a discrete set of amplitudes for each angular
- ❖ position.
- ❖ By interpreting these amplitudes, a table can be established to decode the exact rotary position.

Synchro mechanism - control transmitter and receiver

Schematic of a synchro pair system

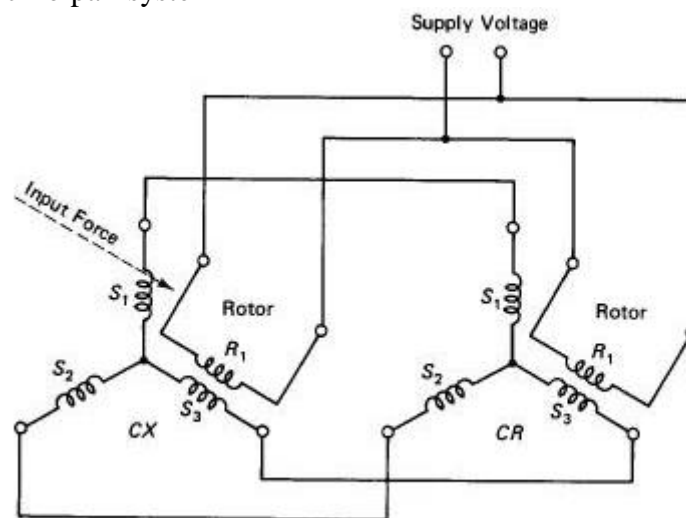

Fig.15.TX -RX synchros in controlling positioning of an antenna

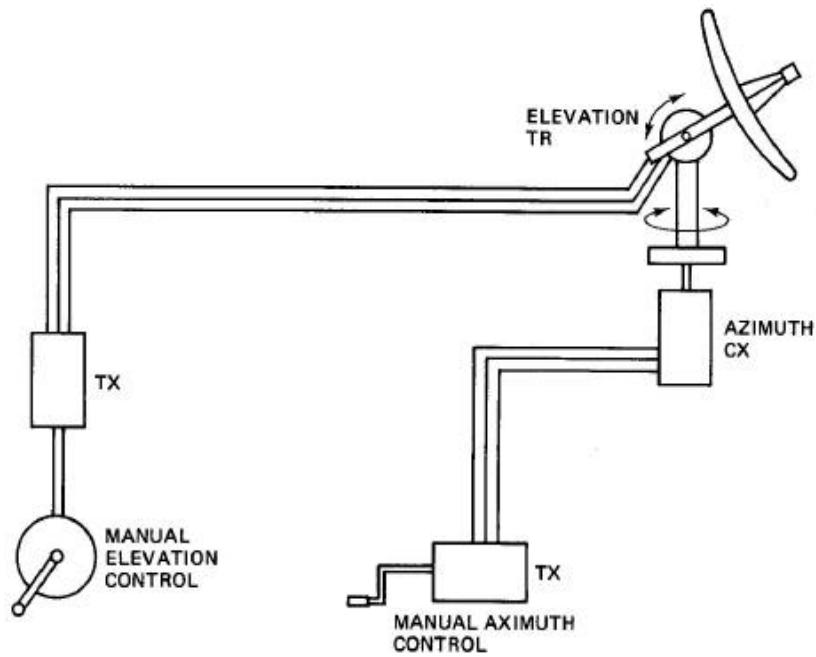

Fig. 16.Application

11. Microsyn

Microsyn - rotary reluctance device used when the angular displacements being measured or controlled are very small (few degrees or so)

- ❖ A microsyn is a variable reluctance transducer that consists of a ferromagnetic rotor and a stator carrying four coils.
- ❖ The stator coils are connected such that at the null position, the voltages induced in coils 1 and 3 are balanced by voltages induced in coils 2 and 4.
- ❖ The motion of the rotor in one direction increases the reluctance of two opposite coils while decreasing the reluctance in others, resulting in a net output voltage e_o .
- ❖ The movement in the opposite direction reverses this effect with a 180° phase shift.

Microsyn construction

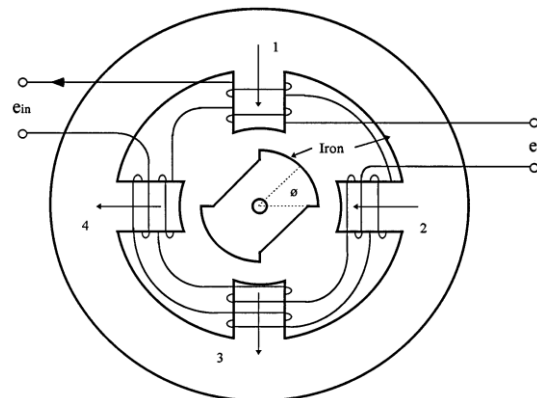

Fig.17. Microsyn

Microsyn used for positioning a mirror in a satellite camera

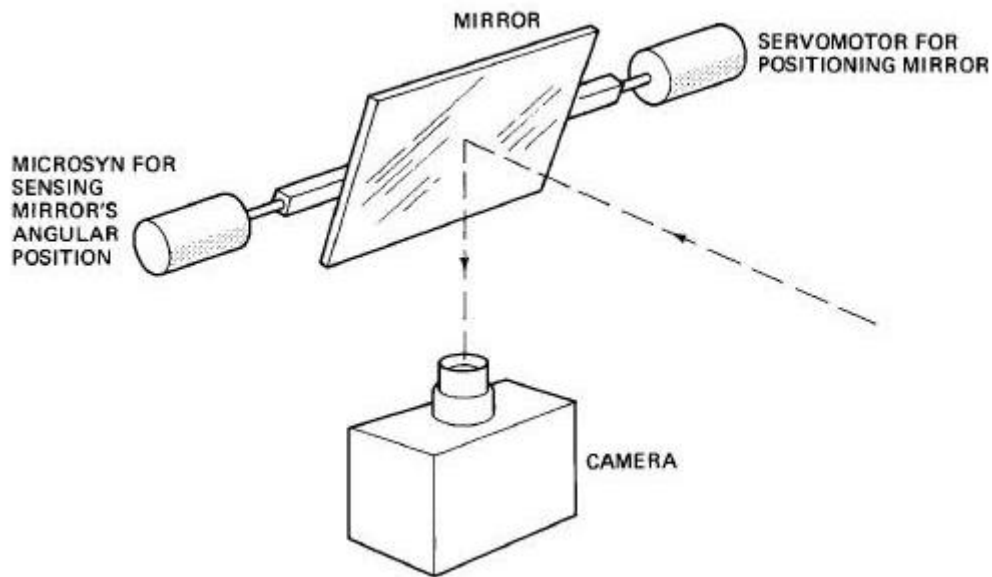

Fig.18. Microsyn application

12. CAPACITIVE TRANSDUCERS

The principle of operation of capacitive transducers are based on the following expression,

The capacitance C of a parallel plate capacitor is given by,

$$C = \epsilon_r \epsilon_0 A / d$$

Where,

ϵ_r is the relative permittivity of the dielectric between the plates,

ϵ_0 permittivity of free space,

A area of overlap between two plates and

d the plate separation.

Capacitive sensor is of non-contact type sensor and is primarily used to measure the linear displacements from few milli meters to hundreds of milli meters.

- ❖ It comprises of three plates, with the upper pair forming one capacitor and the lower pair another.
- ❖ The linear displacement might take in two forms:
 - one of the plates is moved by the displacement so that the plate separation changes
 - Area of overlap changes due to the displacement.
- ❖ The capacitive transducer work on the principle of change of capacitance which may be caused by :

- (i) Change in overlapping area A ,
- (ii) Change in the distance d between the plates
- (iii) change in dielectric constant.

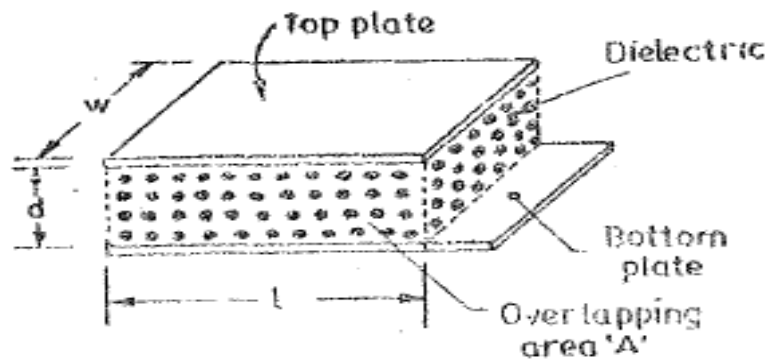

Fig.19.Schematic diagram of parallel plate capacitor

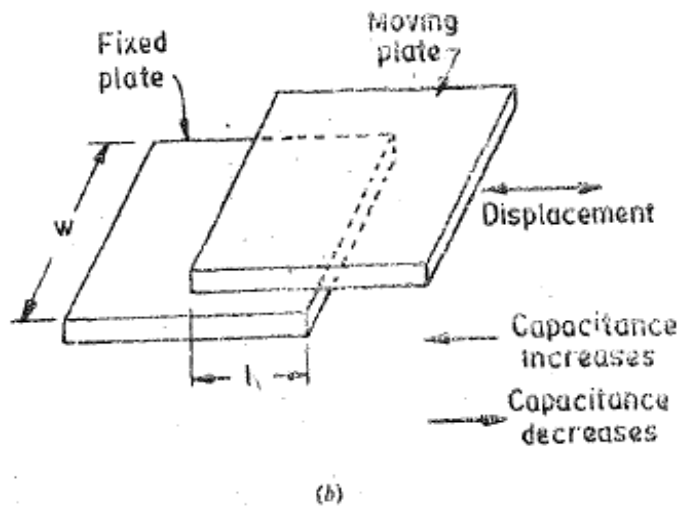
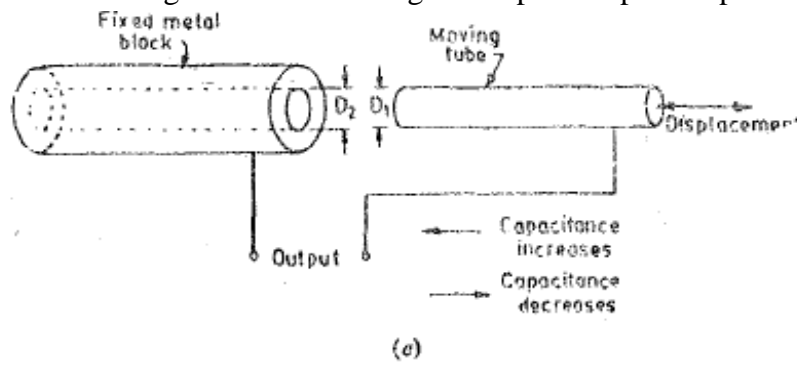

Fig.20. Capacitive transducer using change of area principle

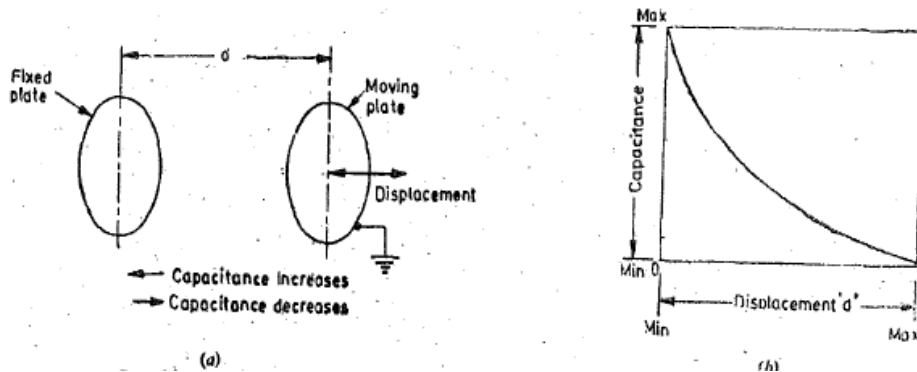

Fig.21. Capacitive transducer using change of distance between plates principle

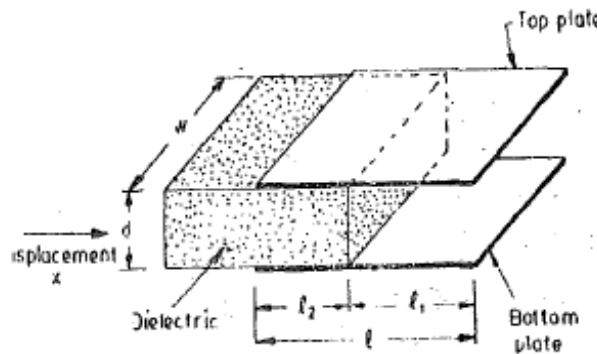

Fig.22. Capacitive transducer using principle of change in dielectric constant for measurement of displacement

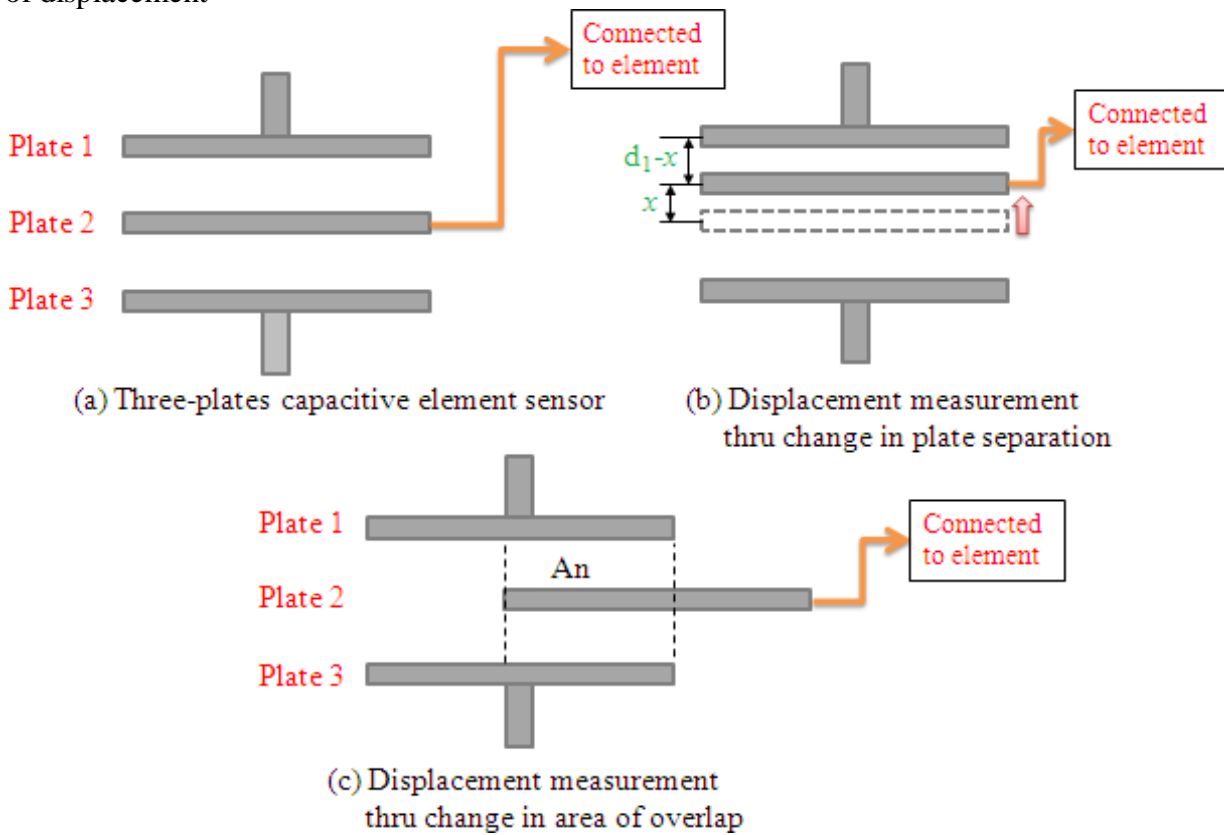

Fig.23. Three plate capacitive sensor

$$C_1 = (\epsilon_r \epsilon_0 A) / (d + x)$$

$$C_2 = (\epsilon_r \epsilon_0 A) / (d - x)$$

When C_1 and C_2 are connected to a Wheatstone's bridge, then the resulting out-of-balance voltage would be in proportional to displacement x .

- ❖ As the central plate moves near to top plate or bottom one due to the movement of the element/work piece of which displacement is to be measured, separation in between the plate changes.
- ❖ Capacitive elements can also be used as proximity sensor. The approach of the object towards the sensor plate is used for induction of change in plate separation. This changes the capacitance which is used to detect the object.

Advantages of Capacitive Transducers.

- ❖ They require extremely small forces to operate them and hence are very useful for use in small systems.
- ❖ They are extremely sensitive.
- ❖ They have a good frequency response.
- ❖ They have a high input impedance and therefore the loading effects are minimum.
- ❖ A resolution of the order of 2.5×10^{-3} mm can be obtained with these transducers.
- ❖ The capacitive transducers can be used for applications where stray magnetic fields render the inductive transducers useless.
- ❖ The force requirement of capacitive transducers is very small and therefore they require small power to operate them.

Disadvantages of Capacitive Transducers.

- ❖ The metallic parts of the capacitive transducers must be insulated from each other. In order to reduce the effects of stray capacitances, the frames must be earthed.
- ❖ The capacitive transducers show non-linear behaviour many a times on account of edge effects. Therefore guard rings must be used to eliminate this effect. Guard rings are also a must in order to eliminate the effect of stray electric fields, especially when the transducers have a low value of capacitance of the order of pF.
- ❖ The output impedance of capacitive transducers tends to be high on account of their small capacitance value.
- ❖ The cable connecting the transducer to the measuring point is also a source of error. The cable may be source of loading resulting loss of sensitivity. Also loading makes the low frequency response poor.

Applications of capacitive transducers:-

1. Feed hopper level monitoring

2. Small vessel pump control
3. Grease level monitoring
4. Level control of liquids
5. Metrology applications
 1. to measure shape errors in the part being produced
 2. to analyze and optimize the rotation of spindles in various machine tools such as surface grinders, lathes, milling machines, and air bearing spindles by measuring errors in the machine tools themselves
6. Assembly line testing
 1. To test assembled parts for uniformity, thickness or other design features
 2. To detect the presence or absence of a certain component, such as glue etc.

13. Capacitor microphone

Principle

Capacitor microphone works on the principle as that of the capacitance transducer.

- It contains a movable diaphragm and a fixed plate
- When the sound waves hit the microphone, the diaphragm moves backwards and forwards.
- This changes the level of capacitance and as a result voltage changes are seen across the resistor connected.

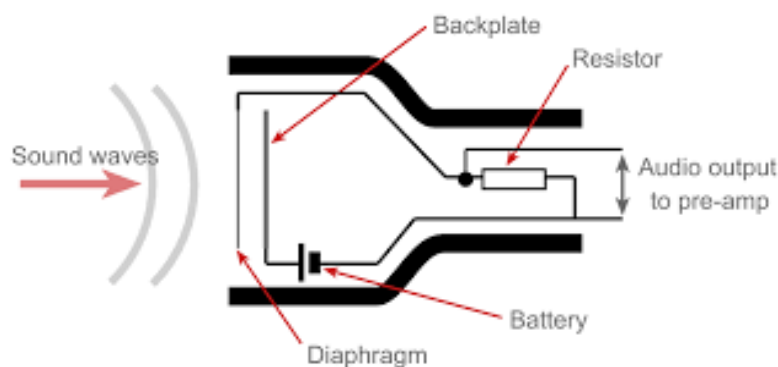

Fig.24._capacitor / condenser microphone



Fig 25. Capacitor microphone

Advantages & Disadvantages

Advantages

- ❖ Typical output impedance is around 200 ohm or less.
- ❖ Frequency ranges from 20Hz to 20KHz and more.
- ❖ High quality sound recording.
- ❖ It is less robust.

Disadvantages

- ❖ High sensitivity, which causes overload due to loud noise.
- ❖ Internal construction is delicate.
- ❖ Sensitive to humid environment.
- ❖ They are damaged more easily than dynamic microphones

14. CAPACITIVE PRESSURE TRANSDUCER – mechanism

- ❖ Pressure-- Diaphragm Motion– Capacitance
- ❖ The deflection of the diaphragm constitutes a capacitor in which the distance between the plates is pressure sensitive.
- ❖ Capacitive Pressure Transducer are use in low vacuum pressure applications.

$$C = \epsilon_0 \epsilon_r A/d$$

Where,

C= capacitance of a capacitor in farad

A = area of each plate in m²

d = distance between two plates in m

ϵ_r = dielectric constant

$\epsilon_0 = 8.854 \times 10^{-12}$ farad/m²

- ❖ Thus, capacitance can be varied by changing distance between the plates, area of the plate or value of the dielectric medium between the plates.
- ❖ Any change in these factors cause change in capacitance.

Construction

1. Capacitive pressure transducer includes:
 - i. a pair of electrically insulative elastic diaphragms disposed adjacent to each other and bonded together in a spaced apart relationship to form a sealed cavity,
 - ii. a conductive layer applied to the inside surface of each of the diaphragms
 - iii. a small absolute pressure provided in the cavity.

- This small absolute pressure cavity essentially reduces the effects of the negative temperature coefficient of the modulus of elasticity of the diaphragms.
2. In capacitive transducers, pressure is utilized to vary any of the above mentioned factors which will cause change in capacitance and that is a measurable by any suitable electric bridge circuit and is proportional to the pressure.

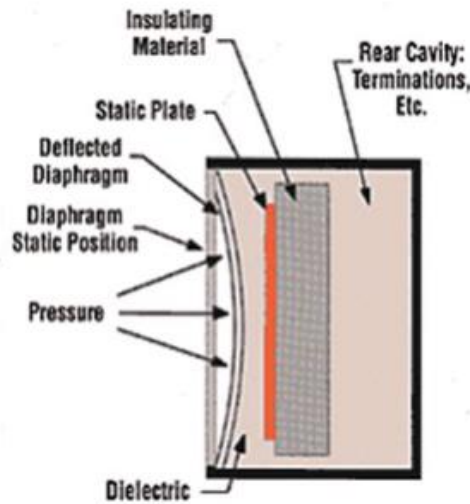

Fig.26. Capacitive pressure transducer Configuration

Configuration

- ❖ The sensing diaphragm and capacitor form a differential variable separation capacitor.
- ❖ When the two input pressures are equal the diaphragm is positioned centrally and the capacitance are equal.
- ❖ A difference in the two input pressure causes displacement of the sensing diaphragm and is sensed as a difference between the two capacitances

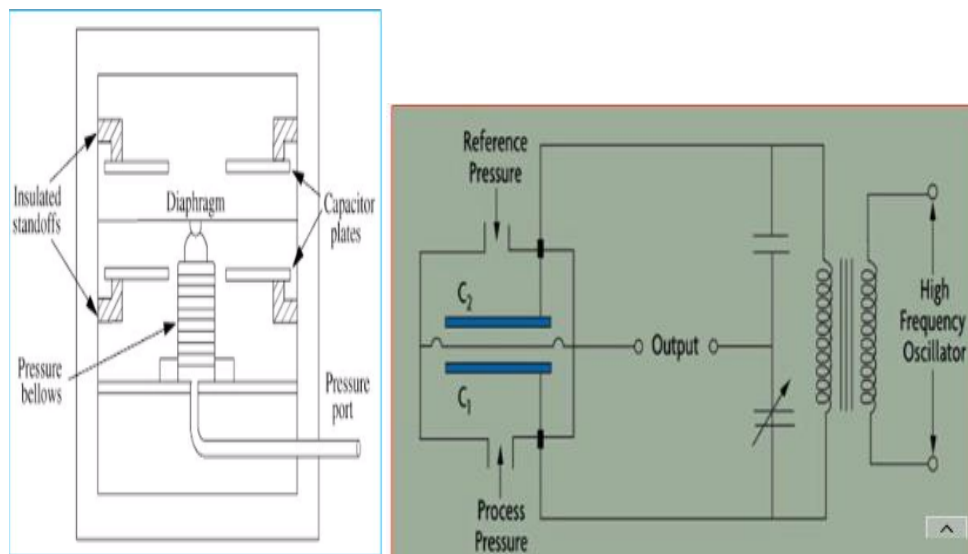

Fig.27. Application of Capacitive pressure transducer

15. CAPACITIVE PROXIMITY SENSORS

- ❖ Capacitive Proximity Sensors detect changes in the capacitance between the sensing object and the Sensor. As per the name, capacitive proximity sensors operate by noting a change in the capacitance read by the sensor.
- ❖ The amount of capacitance varies depending on the size and distance of the sensing object. An ordinary Capacitive Proximity Sensor is similar to a capacitor with two parallel plates, where the capacity of the two plates detected.

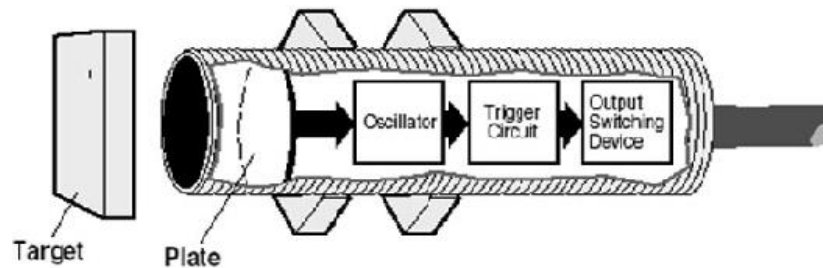

Fig.28. Capacitive proximty sensor

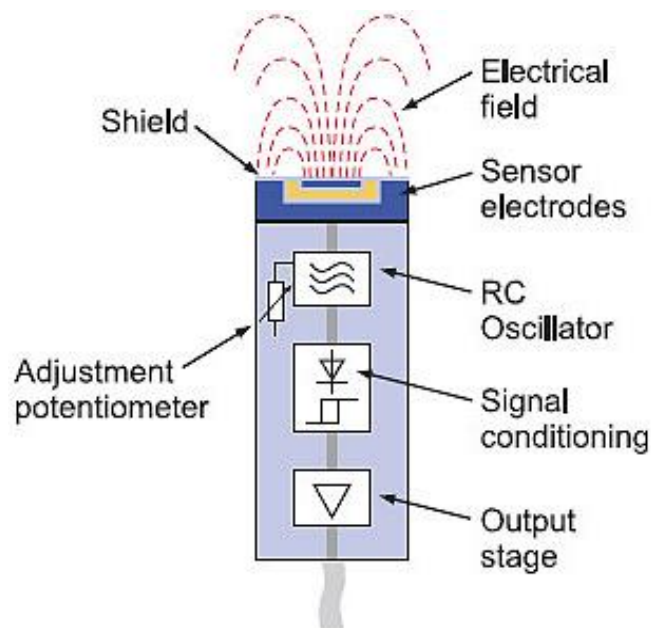

Fig.29. Capacitive proximty sensor

- ❖ One of the plates is the object being measured (with an imaginary ground), and the other is the Sensor's sensing surface.
- ❖ It detects the changes in the capacity generated between these two poles. The detection of the object depends on their dielectric constant, but they include resin and water in addition to metals.
- ❖ The capacitive proximity sensor consist a high-frequency oscillator along with a sensing surface formed by two metal electrodes. When an object comes near the

sensing surface, it enters the electrostatic field of the electrodes and changes the capacitance of the oscillator.

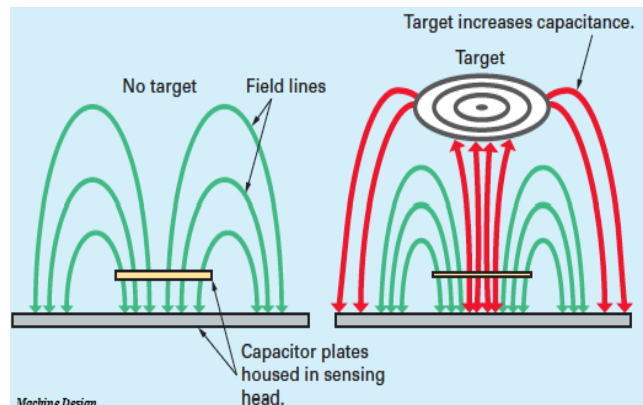

Fig.30. Working mechanism

- ❖ As a result, the oscillator circuit starts oscillating and changes the output state of the sensor when it reaches certain amplitude. As the object moves away from the sensor, the oscillator's amplitude decreases, switching the sensor back to its initial state.
- ❖ A typical sensing range for capacitive proximity sensors is from a few millimeters up to about 1 inch. (or 25 mm), and some sensors have an extended range up to 2 inch. Where capacitive sensors really excel, however, is in applications where they must detect objects through some kind of material such as a bag, bin, or box. They can tune out non-metallic containers and can be tuned or set to detect different levels of liquids or solid materials.
- ❖ The capacitive proximity sensor detects the larger dielectric constant of a target easily. This makes possible the detection of materials inside non metallic containers because the liquid has a much higher dielectric constant than the container, which gives the sensor ability to see through the container and detect the liquid.



Fig. 31. Capacitive proximity sensor

- ❖ For best operation, they should use in an environment with relatively constant temperature and humidity.

- ❖ When dealing with non-conductive targets there are three factors that determine the sensing distance.
 - The size of the active surface of the sensor – the larger the sensing face the longer the sensing distance
 - The capacitive material properties of the target object, also referred to as the dielectric constant – the higher the constant the longer the sensing distance
 - The surface area of the target object to be sensed – the larger the surface area the longer the sensing distance

Other factors that have minimal effect on the sensing distance

- Temperature
- Speed of the target object
- ❖ The point at which the proximity sensor recognizes an incoming target is the **operating point**.
- ❖ The point at which an outgoing target causes the device to switch back to its normal state is the **release point**.
- ❖ The area between operating and release points is the **hysteresis zone**.
- ❖ Most proximity sensors are equip with an LED status indicator to verify the output switching action.

The difference between Inductive and Capacitive Proximity Sensor

- ❖ Inductive sensors use a magnetic field to detect objects. Capacitive sensors use an electric field. In order to be sense by an inductive sensor an object must be conductive. This limits suitable targets to metal objects (for the most part). In order to be sense by a capacitive sensor the target doesn't need to be conductive.
- ❖ A capacitive sensor will react to an object acting as a dielectric material as well as a conductive object. This makes metal and non-metal objects suitable targets.

Advantages of Capacitive proximity sensors

- ❖ Contactless detection
- ❖ A wide array of materials can detect
- ❖ Able to detect objects through non-metallic walls with its wide sensitivity band
- ❖ Well-suited to be used in an industrial environment
- ❖ Contains potentiometer that allows users to adjust sensor sensitivity, such that only wanted objects will be sensed
- ❖ No moving parts, ensuring a longer service life

Disadvantages of Capacitive proximity sensors:-

- ❖ Relative low range, though incremental increase from inductive sensors
- ❖ Higher price as compared to inductive sensors

MULTIPLE CHOICE QUESTIONS

1. In a LVDT, the two secondary voltages

- a) Are independent of the core position
- b) Vary unequally depending on the core position
- c) Vary equally depending on the core position
- d) Are always in phase quadrature

Answer b

2. Which of the following devices is used for conversion of coordinates?

- A. Synchros
- B. Microsyn
- C. Synchros resolver
- D. Synchro transformer

Answer C

3. Which of the following terms accurately describes a synchro?

- a. Electromechanical
- b. Position-sensing
- c. Rotary
- d. All the above

Answer D

4. Microsyn is based on the principle of

- A. DC motor
- B. Resolver
- C. Saturable reactor
- D. Rotating differential transformer

Answer D.

5. Which type of proximity sensor can be used as touch sensor?

- a) Inductive proximity sensor
- b) Capacitive proximity sensor
- c) Ultrasonic proximity sensor
- d) Photoelectric proximity sensor

Answer b

6. What is the relation between the self-inductance and the reluctance of a coil?

- a) Directly proportional
- b) Inversely proportional
- c) No relation
- d) Constant

Answer: b

7. Capacitance of a parallel plate capacitor is _____

- a) $C = A\epsilon/d$
- b) $C = \epsilon/d$
- c) $C = A/d$
- d) $C = A$

Answer: a

8. Which of the following device can be used for displacement measurement?

- a) LVDT
- b) Bellows
- c) Capsule
- d) Bourdon tube

Answer: a

9. Which proximity sensor can detect both metal and non metal objects

- a) Ultrasonic sensor
- b) Inductive proximity sensor
- c) Capacitive proximity sensor
- d) None of these

Answer (c)

10. The principle of operation of LVDT is based on the variation of

- a) Self inductance
- b) Mutual inductance
- c) Reluctance
- d) Permanence

Answer (b)

ASSIGNMENT

1. Describe the construction of LVDT and explain its principle of operation with the aid of diagram, list the advantages, disadvantages and applications of LVDT.
2. Elaborate the working principle of proximity sensors with neat diagram in detail. List its applications.

UNIT III ACTUATORS

Definition, types and selection of Actuators; linear; rotary; Logical and Continuous Actuators, Pneumatic actuator- Electro-Pneumatic actuator; cylinder, rotary actuators, Mechanical actuating system: Hydraulic actuator - Control valves; Construction, Characteristics and Types, Selection criteria.

Electrical actuating systems: Solid-state switches, Solenoids, Electric Motors- Principle of operation and its application: D.C motors - AC motors - Single phase & 3 Phase Induction Motor; Synchronous Motor; Stepper motors - Piezoelectric Actuator.

PNEUMATICS ACTUATORS

1. PNEUMATICS ACTUATORS

Pneumatic actuators are the devices used for converting pressure energy of compressed air into the mechanical energy to perform useful work. In other words, Actuators are used to perform the task of exerting the required force at the end of the stroke or used to create displacement by the movement of the piston. The pressurised air from the compressor is supplied to reservoir. The pressurised air from storage is supplied to pneumatic actuator to do work.

The air cylinder is a simple and efficient device for providing linear thrust or straight line motions with a rapid speed of response. Friction losses are low, seldom exceeds 5 % with a cylinder in good condition, and cylinders are particularly suitable for single purpose applications and /or where rapid movement is required. They are also suitable for use under conditions which preclude the employment of hydraulic cylinders that is at high ambient temperature of up to 200 °C to 250°C.

Their chief limitation is that the elastic nature of the compressed air makes them unsuitable for powering movement where absolutely steady forces or motions are required applied against a fluctuating load, or where extreme accuracy of feed is necessary. The air cylinder is also inherently limited in thrust output by the relatively low supply pressure so that production of high output forces can only be achieved by a large size of the cylinders.

2. TYPES OF PNEUMATICS ACTUATORS

Pneumatic cylinders can be used to get linear, rotary and oscillatory motion. There are three types of pneumatic actuator: they are

- i) Linear Actuator or Pneumatic cylinders
- ii) Rotary Actuator or Air motors
- iii) Limited angle Actuators

Types of Pneumatic cylinders / Linear actuators

Pneumatic cylinders are devices for converting the air pressure into linear mechanical force and motion. The pneumatic cylinders are basically used for single purpose application such as clamping, stamping, transferring, branching, allocating, ejecting, metering, tilting, bending, turning and many other applications.

The different classification scheme of the pneumatic cylinders are given below

A. Based on application for which air cylinders are used

- i) Light duty air cylinders
- ii) Medium duty air cylinders
- iii) Heavy duty air cylinders

B. Based on the cylinder action

- i) Single acting cylinder
- ii) Double acting cylinder
 - Single rod type double acting cylinder
 - Double rod type double acting cylinder

C. Based on cylinder's movement

- i) Rotating type air cylinder
- ii) Non rotating type air cylinder

D. Based on the cylinder's design

- i) Telescopic cylinder
- ii) Tandem cylinder
- iii) Rod less cylinder
 - Cable cylinder,
 - Sealing band Cylinder with slotted cylinder barrel
 - Cylinder with Magnetically Coupled Slide
- iv) Impact cylinder
- v) Duplex cylinders
- vi) Cylinders with sensors

3. Based on application for which air cylinders are used

Air cylinders can be classified according to their intended use, as light duty, medium duty or heavy duty types. In the main this merely governs the strength of the cylinder, and thus typical choice of material of construction and the form of construction. Comparison is given in Table 1. It should be noted that classification by duty does not necessarily affect the output

performance of the cylinder, as bore size for bore size; identical cylinder diameter will give the same thrust on the same line pressure, regardless of whether the cylinder is rated for light, medium or heavy duty. This form of rating, however, normally precludes the use of light classification for cylinders of large size (and thus high thrust); and medium classification for cylinders of even large size and very high thrust outputs.

All plastic construction has the advantage of being inherently free from corrosion and similar troubles but, in general is limited to smaller cylinder sizes and light duty applications. As originally introduced they were intended to provide low cost cylinders for light duty work, and where rigidity of the unit was not an important factor. The development of all-plastic cylinders for higher duties tends to nullify any cost advantage and the types have not, as yet, achieved any particular prominence, although the potentialities remain for corrosion-resistant duties.

Force limitation with air cylinders are purely matter of size and cost. Since line pressures available are usually very much lower than pressure common in hydraulic circuits, air cylinder must be very much larger in diameter than the hydraulic cylinders for the same thrust performance. Where a very high force is required the cost of the suitable size of air cylinder may work out at more than the cost of a complete hydraulic system to do the same job. In addition the cost of the compressed air feed such cylinders could also be prohibitive.

Table 1. Materials of construction for light, medium and heavy duty cylinders

Components	Type of cylinder		
	Light duty	Medium duty	Heavy duty
Cylinder tubes	Hard drawn seamless aluminium or brass tubes Plastics	Hard drawn seamless brass tubes, Aluminium, brass, iron or steel castings	Hard drawn seamless tubing , brass , bronze, iron or steel casting
End covers	Aluminium alloy castings Fabricated aluminium, brass, bronze	Aluminium brass, bronze, iron or steel castings, fabricated brass, bronze	High tensile castings
Pistons	Aluminium alloy castings	Aluminium alloy castings, Brass, cast iron	Aluminium alloy castings, Brass, cast iron
Piston rods	EN 8 or similar steel ground and polished or chrome plated	EN 8 steel, ground and polished or chrome plated. Ground and polished stainless steel	Ground and polished stainless steel
Mounting brackets	Aluminium alloy casting	Aluminium, brass, iron castings	High tensile castings or fabricated

4. Based on the cylinder action

Based on cylinder action we can classify the cylinders as single acting and double acting. Single acting cylinders have single air inlet line. Double acting cylinders have two air inlet lines. Advantages of double acting cylinders over single acting cylinders are

1. In single acting cylinder, compressed air is fed only on one side. Hence this cylinder can produce work only in one direction. But the compressed air moves the piston in two directions in double acting cylinder, so they work in both directions
2. In a single acting cylinder, the stroke length is limited by the compressed length of the spring. But in principle, the stroke length is unlimited in a double acting cylinder
3. While the piston moves forward in a single acting cylinder, air has to overcome the pressure of the spring and hence some power is lost before the actual stroke of the piston starts. But this problem is not present in a double acting cylinder.

A) Single acting cylinders.

Single acting cylinder has one working port. Forward motion of the piston is obtained by supplying compressed air to working port. Return motion of piston is obtained by spring placed on the rod side of the cylinder. Schematic diagram of single acting cylinder is shown in Fig. 1

Single acting cylinders are used where force is required to be exerted only in one direction. Such as clamping, feeding, sorting, locking, ejecting, braking etc., Single acting cylinder is usually available in short stroke lengths [maximum length up to 80 mm] due to the natural length of the spring. Single Acting Cylinder exerts force only in one direction. Single acting cylinders require only about half the air volume consumed by a double acting cylinder for one operating cycle.

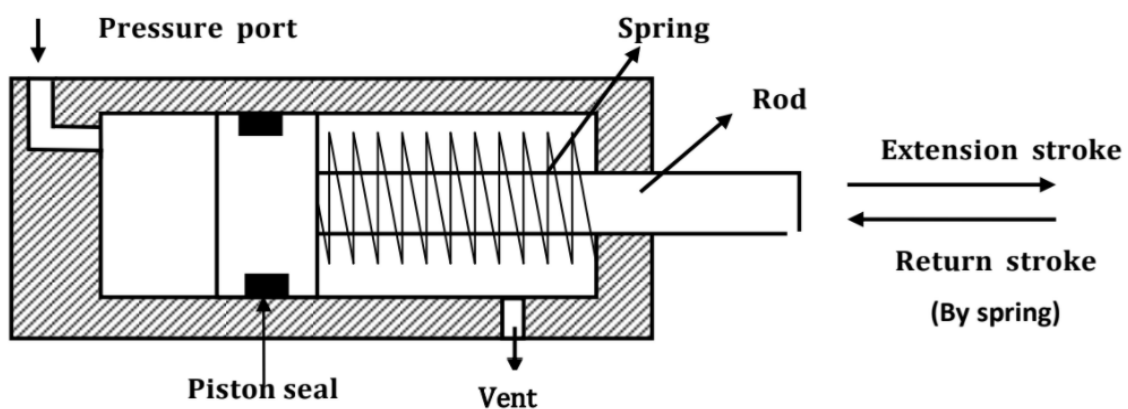

Fig 1. Construction features of single acting cylinder

There are varying designs of single acting cylinders including:

- i. Diaphragm cylinder
- ii. Rolling diaphragm cylinder
- iii. Gravity return single acting cylinder
- iv. Spring return single acting cylinder

i) Diaphragm cylinder

This is the simplest form of single acting cylinder. In diaphragm cylinder, piston is replaced by a diaphragm. The diaphragm is made of hard rubber, plastic or metal clamped between the two halves of a metal casing expanded to form a wide, flat enclosure. Schematic diagram of diaphragm cylinder is shown in Fig.2. The operating stem which takes place of the piston rod in diaphragm cylinder can also be designed as a surface element so as to act directly as a clamping surface for example. Only short operating strokes can be executed by a diaphragm cylinder, up to a maximum of 50 mm. This makes the diaphragm type of cylinder particularly adaptable to clamping operations. Return stroke is accomplished by a spring built into the assembly or by the tension of diaphragm itself in the case of very short stroke. Diaphragm cylinders are used for short stroke application like clamping, riveting, lifting, embossing and riveting

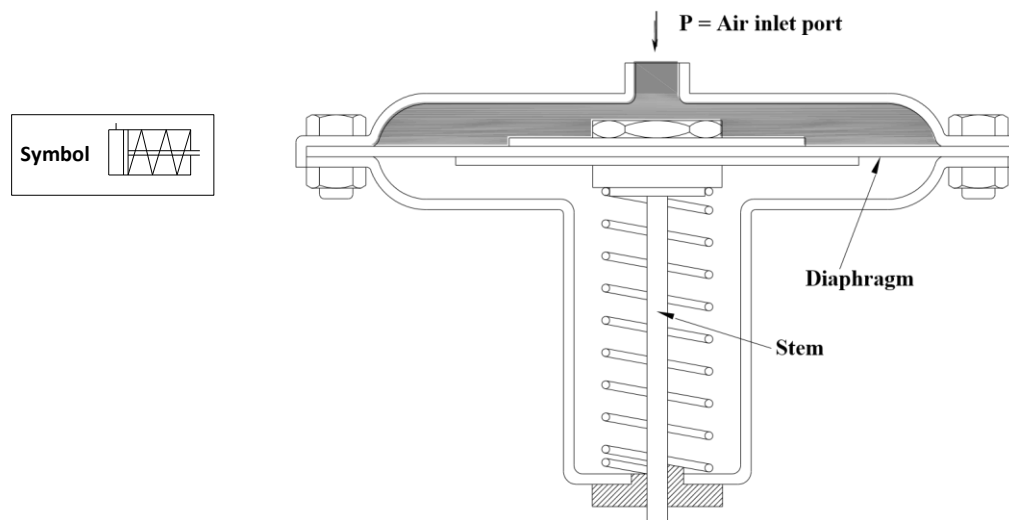

Fig.2 Construction features of diaphragm cylinder

ii) Rolling diaphragm cylinder

They are similar to diaphragm cylinders. Schematic diagram of Rolling diaphragm cylinder is shown in Fig.3. They too contain a diaphragm instead of piston, which in this instance rolls out along the inner walls of the cylinder when air pressure is applied to the device, thereby causing the operating stem to move outwards. Compared with the standard diaphragm type, a

rolling diaphragm cylinder is capable of executing appreciably longer operating strokes (averaging from 50 mm to 800mm). Separate guiding of stem is not normally provided in these designs, since the component being actuated by the cylinder usually cannot break out of set limits of motion. Any off-center displacement is compensated by the rolling diaphragm with no loss of power. Materials used for rolling diaphragms in present –day designs ensure good durability under normal operating conditions. On the other hand, even very small cracks or cuts in the diaphragm will generally lead to early failure because if high stresses are imposed on the flexible material as it unrolls at each stroke. If the actuator needs to be dismantled for any reason, it must accordingly be inspected carefully for any burrs or sharp edges inside. Metal cuttings also constitute a hazard if they are able to enter the cylinder housing.

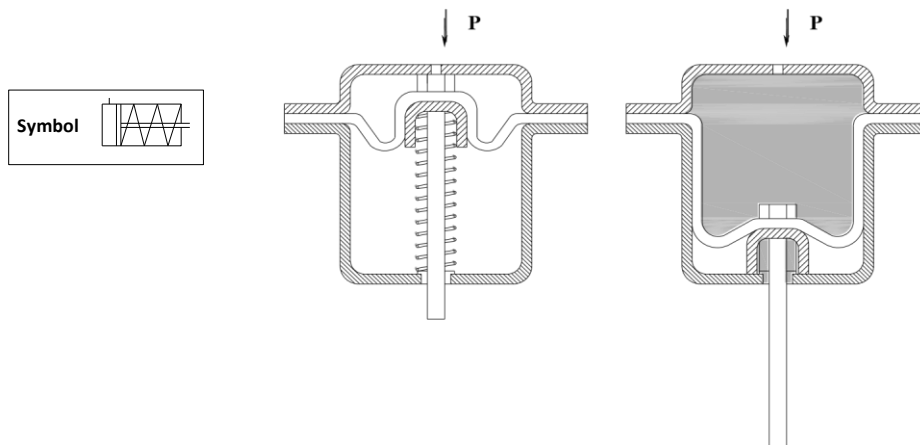

Fig 3 Construction features of rolling diaphragm cylinder

iii) Gravity Return Single Acting Cylinders

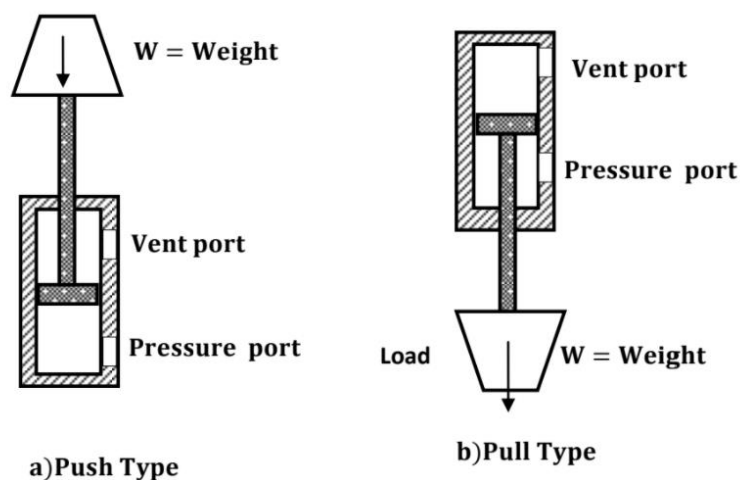

Fig 4. Gravity return type single acting cylinders

Fig.4 shows gravity return type single acting cylinders. In a push type (a), the cylinder extends to lift a weight against the force of gravity by applying oil pressure at the blank end.

The oil is passed through blank end port or pressure port. The rod end port or vent port is open to atmosphere so that air can flow freely in and out of the rod end of the cylinder. To retract the cylinder, the pressure is simply removed from the piston by connecting the pressure port to the tank. This allows the weight of the load to push the fluid out of the cylinder back to tank. In pull type gravity return type single acting cylinder the cylinder (b) lifts the weight by retracting. The blank end port is the pressure port and blind end port is now the vent port. This cylinder will automatically extend whenever the pressure port is connected to the tank.

iv) Spring Return Single Acting Cylinder

Spring return single acting cylinder is shown in Fig.5 in part (a) push type the pressure is sent through pressure port situated at blank end of the cylinder. When the pressure is released, the spring automatically returns the cylinder to the fully retracted position. The vent port is open to atmosphere so that air can flow freely in and out of the rod end of the cylinder. Part (b) shows a spring return single acting cylinder. In this design cylinder retracts when the pressure port is connected to the pump flow and extend whenever the pressure port is connected to the tank. Here pressure port is situated at rod end of the cylinder.

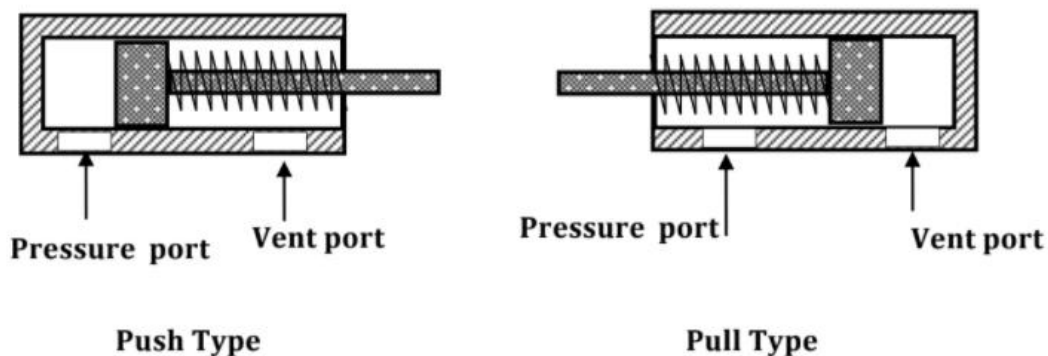

Fig.5 Push and Pull type Single Acting Cylinder

B) Double acting cylinders

Schematic diagram of double acting cylinder is shown in Fig.6. Double Acting Cylinders are equipped with two working ports- one on the piston side and the other on the rod side. To achieve forward motion of the cylinder, compressed air is admitted on the piston side and the rod side is connected to exhaust.

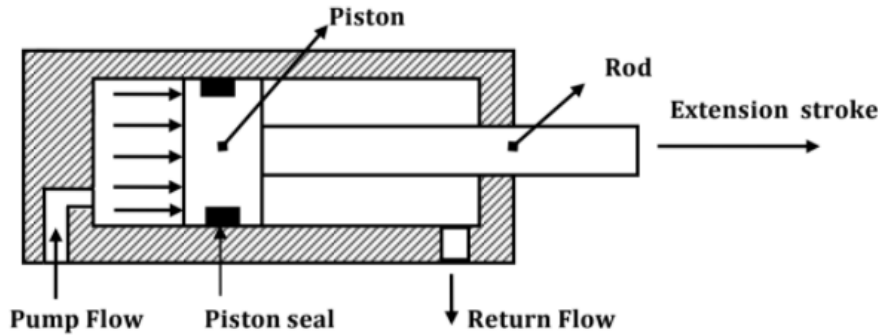

Fig.6. Double acting cylinder

During return motion supply air admitted at the rod side while the piston side volume is connected to the exhaust. Force is exerted by the piston both during forward and return motion of cylinder. Double acting cylinders are available in diameters from few mm to around 300 mm and stroke lengths of few mm up to 2 meters

Construction of Double acting cylinder

The construction features of double acting cylinder are shown in Fig 7. The construction of double acting cylinder is similar to that of a single cylinder. However, there is no return spring. In double acting cylinder, air pressure can be applied to either side (supply and exhaust) of the piston, thereby providing a pneumatic force in both directions. The double acting cylinders are mostly commonly used in the application where larger stroke length is required.

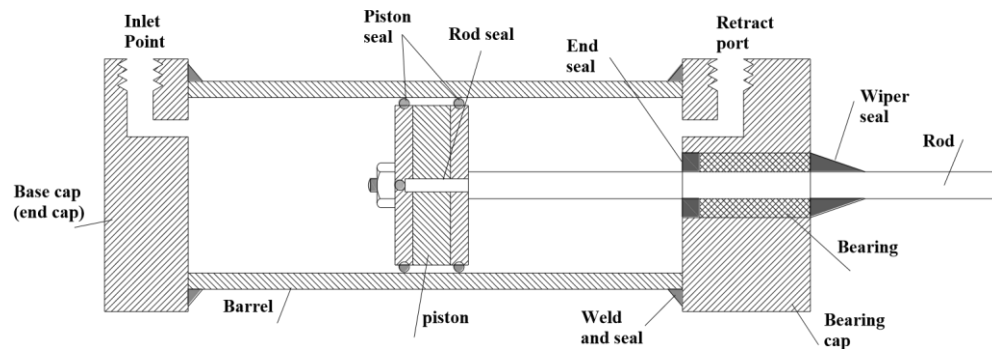

Fig 7 Construction features of double acting cylinder

The seven parts of the double acting cylinder are

1. Base cap with port connection
2. Bearing cap with port connection
3. Cylinder barrel
4. Piston
5. Piston rod
6. Scrapper rings
7. Seals

The **base cap** and **bearing cap** are made of cast material, aluminium or malleable cast iron. The two caps can be fastened to the cylinder barrel by tie rods, threads or flanges.

Cylinder barrel is usually made of seamless drawn steel tube to increase the life of the sealing components, the bearing surfaces of the cylinder are precision machined,. For special applications, the cylinder barrel can be made of aluminium, brass or steel tube with hard chromed bearing surface. These special designs are used where operation is infrequent or where there are corrosive influences.

The piston rod It is preferably made from heat treated steel. A certain percentage of chrome in the steel protects against rusting. Generally the threads are rolled to reduce the danger of fracture.

Piston seals are provided in between piston and barrel to avoid leakage. A **sealing ring** is fitted in the bearing cap to seal the piston rod. The bearing bush guides the piston rod and may be made of sintered bronze or plastic coated metal.

In front of this bearing bush is a scrapper ring.(wiper ring). It prevents dust and dirt particles from entering the cylinder space. Bellows are therefore not normally required.

The materials for the double cup packing sealing are

Perbunan, for -20 °C to + 80°C

Viton, for -20 °Cto +190°C

Teflon for -80 °Cto +200°C

O rings are normally used for static sealing.

Construction of Double acting cylinder

There are two types of double acting cylinders.

- i) Double acting cylinder with piston rod on one side.
- ii) Double acting cylinder with piston rod on both sides

i) Double acting cylinder with piston rod on one side.

Fig 8 shows the operation of a double acting cylinder with piston rod on one side. To extend the cylinder, pump flow is sent to the blank end port as in Fig.8 (a).

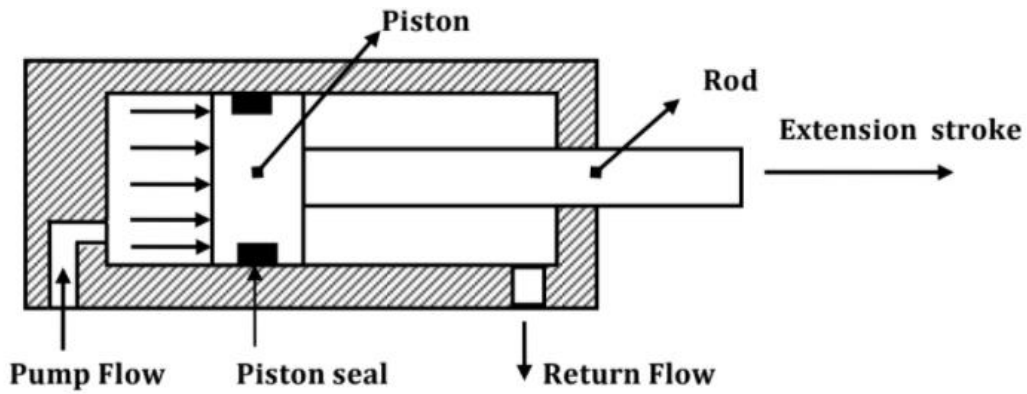

Fig. 8.a) Double acting Cylinder with piston rod on one side (Extension stroke)

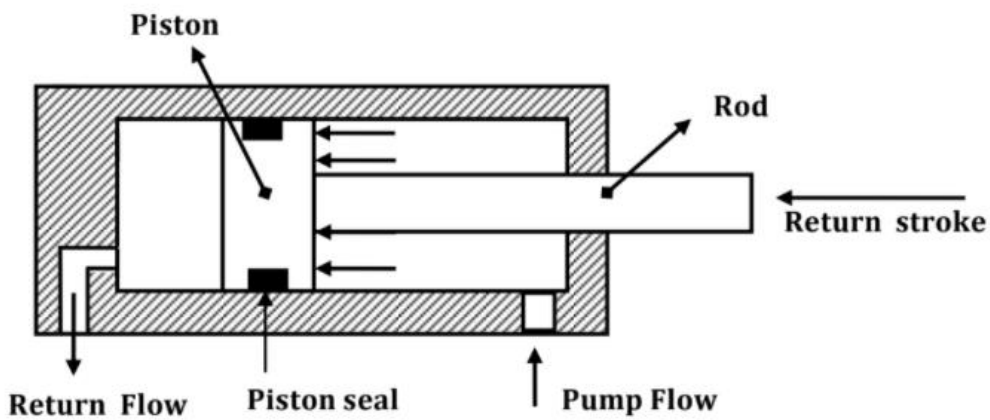

Fig. 8.b) Double acting Cylinder with piston rod on one side (Return stroke)

Fluid from the rod end port returns to the reservoir. To retract the cylinder, the pump flow is sent to the rod end port and fluid from the blank end port returns to the tank as in Fig.8 (b).

iii) Double Acting Cylinder with piston rod on both sides

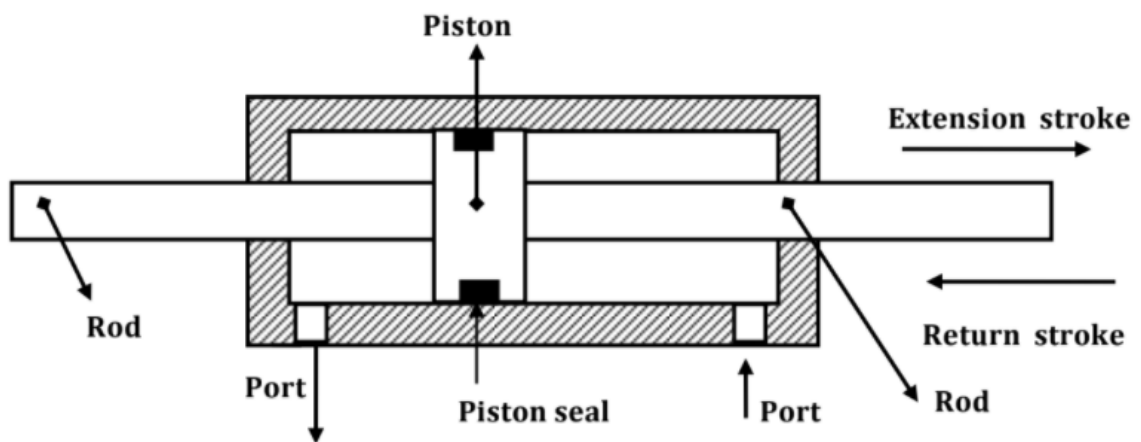

Fig.9 Double Acting Cylinder with piston rod on both side

A double acting cylinder with piston rod on both sides (Fig.9) is a cylinder with rod extending from both ends. This cylinder can be used in an application where work can be done by both ends of the cylinder, thereby making the cylinder more productive. Double rod cylinders can withstand higher side loads because they have an extra bearing one on each rod to withstand the loading. Double rod cylinders are used when there is bending load and accurate alignment and maximum strength is required. A further advantage is that rod is precisely located and may be used to guide the machine member coupled to it, dispensing with external guides or bearing in many cases, most standard production models are available either in single rod or double rod configuration. A disadvantage of double rod configuration is that there is a reduction in maximum thrust due to the blanking effect of the rod cross section on the piston area and a slightly larger size of cylinder is required for a given duty. The thus will be the same on the ingoing stroke as that of a single rod double acting cylinder.

5. Based on the cylinder action

Rotating type of cylinders are used in applications where cylinder body is connected to a rotating member and air connection to the cylinder in a stationary housing. They are not widely used.

Non Rotating type of cylinders are widely used Industries. Cylinder body is connected air connection are mounted stationary housing and piston rod moves and exerts force.

6. Based on the cylinder's design

In industry, differentiation is made between special design of regular cylinder and the special duty cylinders designed for a special purpose that are known by designation of their own. Special design cylinders are basically natural variations of single or double acting cylinders. Variations in special designs derived from standard production of cylinders and merely exchanging selected parts for others of different shapes or material. Special duty cylinders on the other hand are from the start designed to non-standard conditions of service or application. Following section deals with some of commonly used special design and special duty cylinders.

7. CONTROL VALVES

Introduction

The control action in any control loop system, is executed by the final control element. The most common type of final control element used in chemical and other process control is the control valve. A control valve is normally driven by a diaphragm type pneumatic actuator

that throttles the flow of the manipulating variable for obtaining the desired control action. A control valve essentially consists of a plug and a stem. The stem can be raised or lowered by air pressure and the plug changes the effective area of an orifice in the flow path. A typical control valve action can be explained using Fig.10. When the air pressure increases, the downward force of the diaphragm moves the stem downward against the spring.

Classifications

Control valves are available in different types and shapes. They can be classified in different ways; based on: (a) action, (b) number of plugs, and (c) flow characteristics.

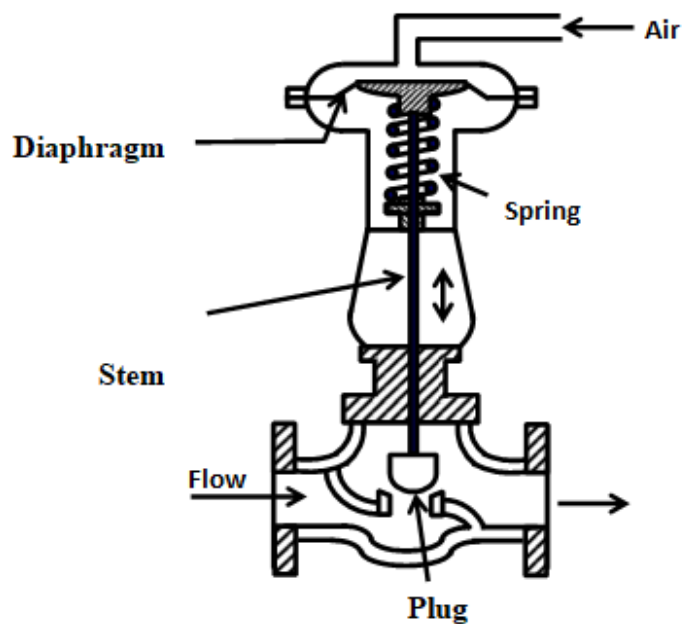

Fig. 10 Control valve

(a) **Action:** Control valves operated through pneumatic actuators can be either (i) air to open, or (ii) air to close.

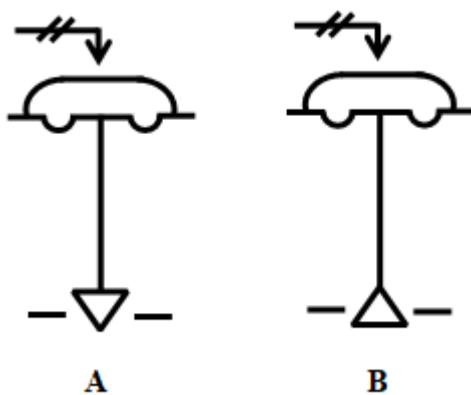

Fig. 11 Air to open and Air to close valves

- **Fail open or Air to close : A**
- **Fail closed or Air to open : B**

They are designed such that if the air supply fails, the control valve will be either fully open, or fully closed, depending upon the safety requirement of the process. For example, if the valve is used to control steam or fuel flow, the valve should be shut off completely in case of air failure. On the other hand, if the valve is handling cooling water to a reactor, the flow should be maximum in case of emergency. The schematic arrangements of these two actions are shown in Fig.11. Valve A are air to close type, indicating, if the air fails, the valve will be fully open. Opposite is the case for valve B.

(b) Number of plugs: Control valves can also be characterized in terms of the number of plugs present, as *single-seated valve* and *double-seated valve*. The difference in construction between a single seated and double-seated valve are illustrated in Fig. 12. Referring Fig.10 (and also Fig. 12(a)), only one plug is present in the control valve, so it is single seated valve. The advantage of this type of valve is that, it can be fully closed and flow variation from 0 to 100% can be achieved. But looking at its construction, due to the pressure drop across the orifice a large upward force is present in the orifice area, and as a result, the force required moving the the valve against this upward thrust is also large. Thus this type of valves is more suitable for small flow rates. On the other hand, there are two plugs in a double-seated valve; flow moves upward in one orifice area, and downward in the other orifice. The resultant upward or downward thrust is almost zero. As a result, the force required to move a double-seated valve is comparatively much less.

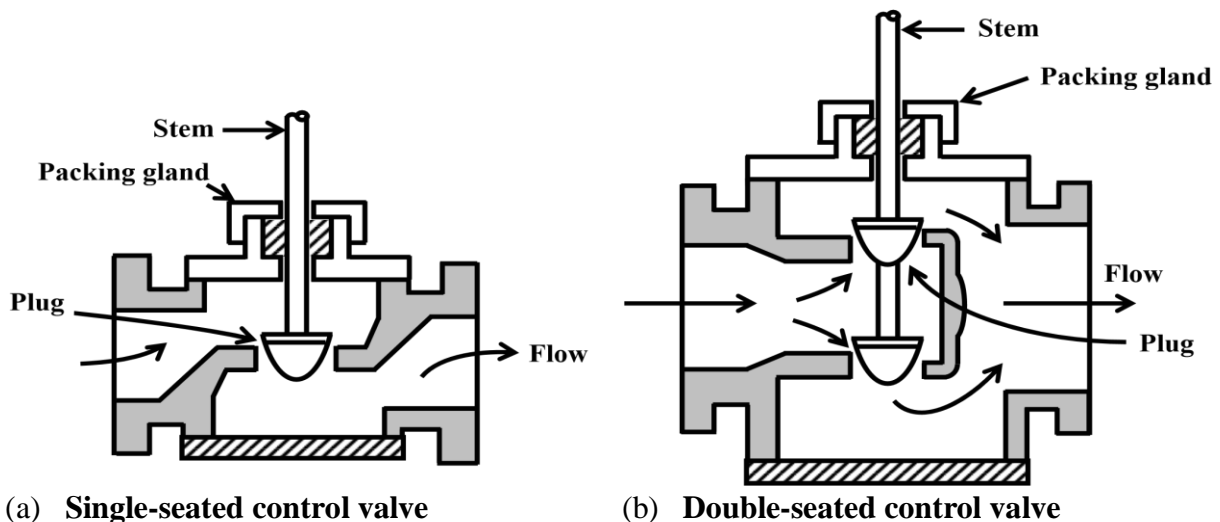

Fig. 12 Single-seated and double-seated valves

But the double-seated valve suffers from one disadvantage. The flow cannot be shut off completely, because of the differential temperature expansion of the stem and the valve

seat. If one plug is tightly closed, there is usually a small gap between the other plug and its seat. Thus, single-seated valves are recommended for when the valves are required to be shut off completely. But there are many processes, where the valve used is not expected to operate near shut off position. For this condition, double-seated valves are recommended.

(c) Flow Characteristics: It describes how the flow rate changes with the movement or lift of the stem. The shape of the plug primarily decides the flow characteristics. However, the design of the shape of a control valve and its shape requires further discussions. The flow characteristic of a valve is normally defined in terms of (a) inherent characteristics and (b) effective characteristics. An inherent characteristic is the ideal flow characteristics of a control valve and is decided by the shape and size of the plug. On the other hand, when the valve is connected to a pipeline, its overall performance is decided by its effective characteristic.

8. Ideal Characteristics

The control valve acts like an orifice and the position of the plug decides the area of opening of the orifice. Recall that the flow rate through an orifice can be expressed in terms of the upstream and downstream static pressure heads as:

$$q = K_1 a \sqrt{2g(h_1 - h_2)} \quad (1)$$

Where q = flow rate in m^3/sec .

K_1 = flow coefficient

a = area of the control valve opening in m^2

h_1 = upstream static head of the fluid in m

h_2 = downstream static head of the fluid in m

g = acceleration due to gravity in m/sec^2 .

Now the area of the control valve opening (a) is again dependent on the stem position, or the lift. So if the upstream and downstream static pressure heads are somehow maintained constant, then the flow rate is a function of the lift (z), i.e.

$$q = f(z) \quad (2)$$

The shape of the plug decides, how the flow rate changes with the stem movement, or lift; and the characteristics of q vs. z is known as the inherent characteristics of the valve.

Let us define

$$m = \frac{q}{q_{\max}} \quad \text{and} \quad x = \frac{z}{z_{\max}}$$

Where, q_{\max} is the maximum flow rate, when the valve is fully open and z_{\max} is the corresponding maximum lift. So eqn. (2) can be rewritten in terms of m and x as:

$$m = f(x) \quad (3)$$

and the valve sensitivity is defined as dm/dx , or the slope of the curve m vs. x . In this way, the control valves can be classified in terms of their m vs. x characteristics, and three types of control valves are normally in use. They are:

- (a) Quick opening
- (b) Linear
- (c) Equal Percentage.

The characteristics of these control valves are shown in Fig.13. It has to be kept in mind that all the characteristics are to be determined after maintaining constant pressure difference across the valve as shown in Fig.13.

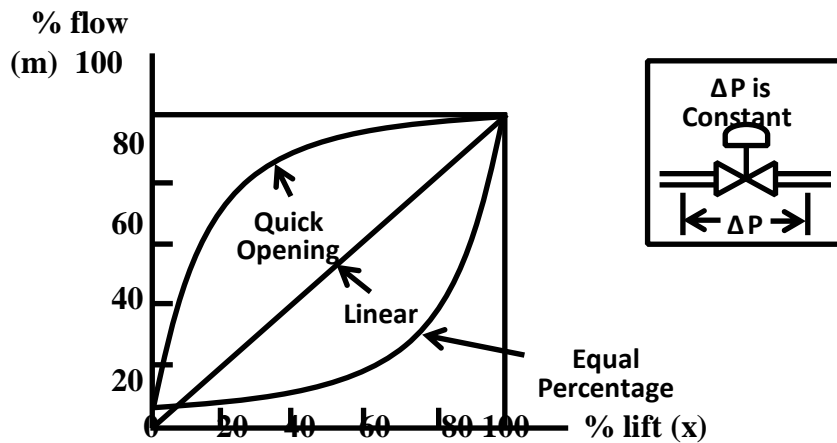

Fig. 13 Flow characteristics of control valves

Different flow characteristics can be obtained by properly shaping the plugs. Typical shapes of the three types of valves are shown in Fig.14.

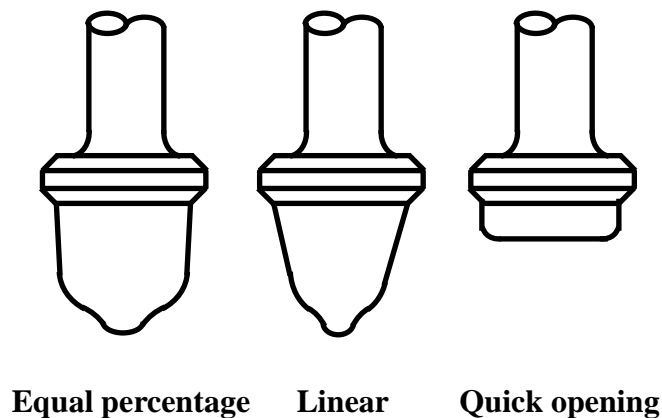

Fig. 14. Valve plug shapes for the three common flow characteristics.

For a linear valve, $dm/dx=1$, as evident from Fig.14 and the flow characteristics is linear throughout the operating range. On the other hand, for an equal percentage valve, the flow characteristics are mathematically expressed as:

$$\frac{dm}{dx} = \beta m \quad (4)$$

Where β is a constant.

The above expression indicates that the slope of the flow characteristics is proportional to the present flow rate, justifying the term equal percentage. This flow characteristic is linear on a semi log graph paper. The minimum flow rate m_0 (flow rate at $x=0$) is never zero for an equal percentage valve and m can be expressed as:

$$m = m_0 e^{\beta x} \quad (5)$$

Rangeability of a control valve is defined as the ratio of the maximum controllable flow and the minimum controllable flow. Thus:

$$\text{Rangeability} = \frac{\text{maximum controllable flow}}{\text{minimum controllable flow}}$$

Rangeability of a control valve is normally in between 20 and 70.

9. Effective Characteristics

So far we have discussed about the ideal characteristics of a control valve. It is decided by the shape of the plug, and the pressure drop across the valve is assumed to be held constant. But in practice, the control valve is installed in conjunction with other equipment, such as heat exchanger, pipeline, orifice, pump etc. The elements will have their own flow vs. pressure characteristics and cause additional frictional loss in the system and the effective characteristics of the valve will be different from the ideal characteristics. In order to explain the deviation, let us consider a control valve connected with a pipeline of length L in between two tanks, as shown in Fig. 6. We consider the tanks are large enough so that the heads of the two tanks H_0 and H_2 can be assumed to be constant. We also assume that the ideal characteristic of the control valve is linear. From eqn. (1), we can write for a linear valve:

$$K_1 a = K z$$

where K is a constant and z is the stem position or lift.

Now the pipeline will experience some head loss that is again dependent on the velocity of the fluid.

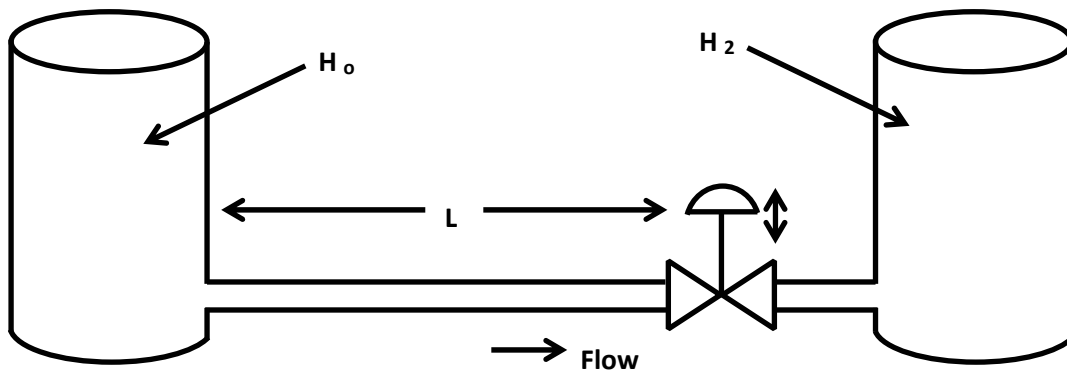

Fig.15. Effect of friction loss in pipeline for a control valve

The head loss Δh_L will affect the overall flow rate q and eqn.(1) can be rewritten as:

$$q = \left[K \sqrt{2g(H_0 - H_2 - \Delta h_L)} \right] z \quad (6)$$

The head loss (in m) can be calculated from the relationship:

$$\Delta h_L = F \frac{L}{D} \frac{v^2}{2g} \quad (7)$$

where F = Friction coefficient

L = Length of the pipeline in m

D = inside diameter of the pipeline in m

v = velocity of the flow in m.

Further, the velocity of the fluid can be related to the fluid flow q (in m³/sec) as:

$$v = \frac{q}{\frac{\pi}{4} D^2} \quad (8)$$

Combining (7) and (8), we can write:

$$\Delta h_L = \frac{8}{\pi^2} \frac{FL}{gD^5} q^2 \quad (9)$$

Substituting (9) in (6) and further simplifying, one can obtain:

$$q = \left[K \sqrt{\frac{2g(H_0 - H_2)}{1 + \alpha z^2}} \right] z$$

where $\alpha = \frac{16FLK^2}{\pi^2 D^5}$ (10)

From (10), it can be concluded that q is no longer linearly proportional to stem lift z , though the ideal characteristics of the valve is linear. This nonlinearity of the characteristics is dependent on the diameter of the pipeline D ; i.e. smaller the pipe diameter, larger is the value of α and more is the nonlinearity. The nonlinearity of the effective valve characteristics can be plotted as shown in Fig.16.

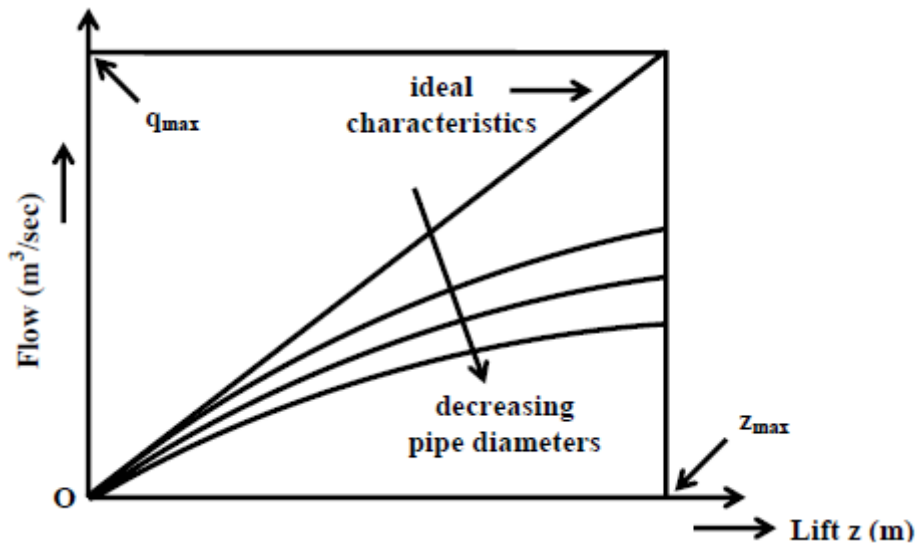

Fig. 16. Effect of pipeline diameter on the effective flow characteristics the control valve

The nonlinearity introduced in the effective characteristics can be reduced by mainly

- (i) increasing the line diameter, thus reducing the head loss,
- (ii) increasing the pressure of the source H_0 ,
- (iii) decreasing the pressure at the termination H_2 .

The effective characteristics of the control valve shown in Fig.16 are in terms of absolute flow q rate. If we want to express the effective characteristics in terms of $m(=q/q_{\max})$ in eqn. (3) q_{\max} deviation from the ideal characteristics will also be observed. Linear valve characteristics will deviate upwards, as shown in Fig.17. An equal percentage valve characteristic will also shift upward from its ideal characteristic; thus giving a better linear response in the actual case.

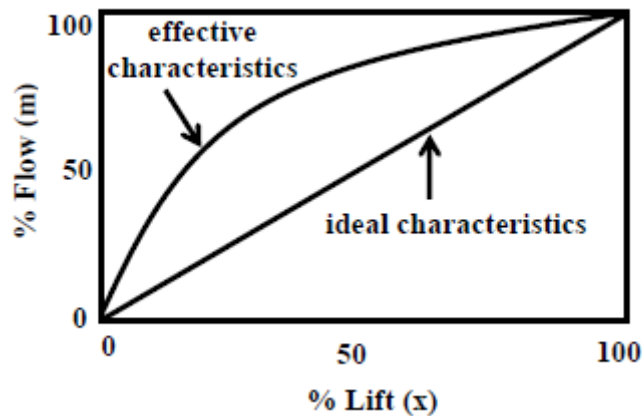

Fig.17. Comparison of ideal and effective characteristics for a linear valve

Thus linear valves are recommended when pressure drop across the control valve is expected to be fairly constant. On the other hand, equal percentage valves are recommended when the pressure drop across the control valve would not be constant due to the presence of series resistance in the line. As the line loss increases, the effective characteristics of the equal percentage valve will move closer to the linear relationship in m vs. x characteristics.

10. Selection criteria for control valve

- Type of fluid to be controlled.
- Temperature, viscosity, specific gravity of fluid.
- Flow capacity (maximum and minimum).
- Inlet and outlet pressure (minimum and maximum).
- Pressure drop at normal and shutoff condition.
- Degree of flashing, if possible.
- Desired action against failure (Fail to open, fail to close).
- End connections and body material (ASTM A216 grade WCC, ASTM A217 grade WC9, ASTM A351 CF8M etc.)
- Valve size
- Valve body (angle, double-port, butterfly etc)
- Valve plug guiding(cage, port guiding etc)
- Port size(full or partial restriction)
- Valve trim material.
- Actuator size required.
- Bonnet style (plain, extension bonnet required).

- Stem travel versus flow characteristics.
- Range-ability.
- Ability to cope with high pressure.
- Valve sizing (valve must operate between 40% to 70% of full operating range).

Rule of thumb:

1) Equal percentage:

- Used where large changes in process drop is expected.
- Used where small % of total pressure drop is permitted.
- Used in temperature & pressure control loops.

2) Linear:

- Used in Level or flow loops.
- Used in system where pressure drop across valve remains constant.

3) Quick opening:

- Used for ON/OFF services.
- Used where instantly “large flow “is needed (safety or cooling system).

Electrical Actuating Systems

1. Solid-State Switches

1.1 P-N Junction Diode

P-N junction diode is two-terminal or two-electrode semiconductor device, which allows the electric current in only one direction while blocks the electric current in opposite or reverse direction. If the diode is forward biased, it allows the electric current flow. On the other hand, if the diode is reverse biased, it blocks the electric current flow. Thus the P-N diode acts as a switch. It will be acts as ON switch when it is forward biased and acts as OFF switch during reverse biased.

The p-n junction diode is made from the semiconductor materials such as silicon, germanium, and gallium arsenide. For designing the diodes, silicon is more preferred over germanium. The p-n junction diodes made from silicon semiconductors work at higher temperature when compared with the p-n junction diodes made from germanium semiconductors.

The basic symbol of p-n junction diode under forward bias and reverse bias is shown in the below figure

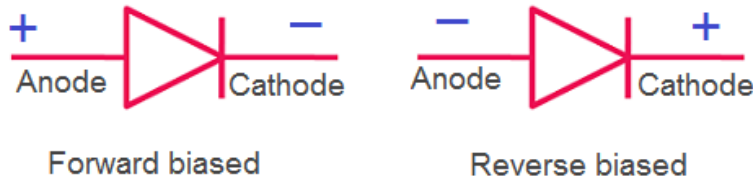

A P-N junction is the simplest form of the diode which behaves as ideally short circuit when it is in forward biased (switch ON) and behaves as ideally open circuit when it is in the reverse biased (switch OFF) .

During ‘ON’ state, the diode offers low resistance called as the ‘Forward resistance’ and high resistance during reverse biased condition. The diode requires a minimum forward bias voltage to switch to the ‘ON’ condition which is called Cut-in-voltage. In reverse biased mode the diode won’t conduct and acts as ‘OFF’ switch. When the reverse bias voltage exceeds its PIV limit, the diode gets damaged which is called as the Breakdown voltage.

The following circuit explains the diode acting as a switch:

A switching diode has a PN junction in which P-region is lightly doped and N-region is heavily doped. The above circuit symbolizes that the diode gets ON when positive voltage forward biases the diode and it gets OFF when negative voltage reverse biases the diode.

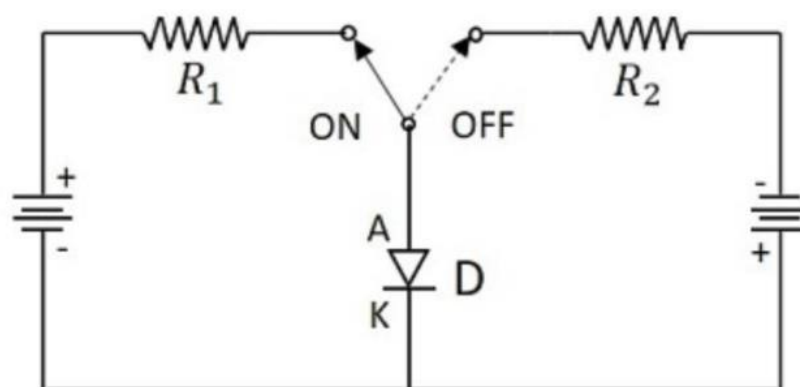

Fig.1. Diode as a Switch

1.2 Bipolar Junction Transistor

BJT is the short form of Bipolar Junction Transistor, it is a solid-state current-controlled device Technically speaking, BJT is a three-terminal device with an Emitter,

collector, and a base pin, the current flow through the emitter and collector are controlled by the amount of current applied to the base. The Fig 2 shows the symbols of the two types of transistors. The one on the left is the symbol of the PNP transistor and the one on the right is the symbol of the NPN transistor. The difference between the PNP and NPN transistors is that the arrow mark at the emitter end if you have noticed, the arrow in the PNP transistor is mentioned as moving from the emitter to the base whereas in the NPN transistor the arrow will be moving from the base to the emitter. The Direction of the arrow represents the direction of current flow in the transistor.

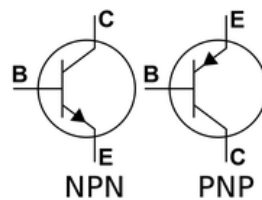

Fig 2. Transistor - symbol

How does a BJT act as a switch?

A transistor has three regions of operation: Active region cut off region and the saturation region. The transistor acts as a switch in the cut-off region and the saturation mode. The transistor is fully **OFF** in the cutoff region and fully **ON** in the saturation region.

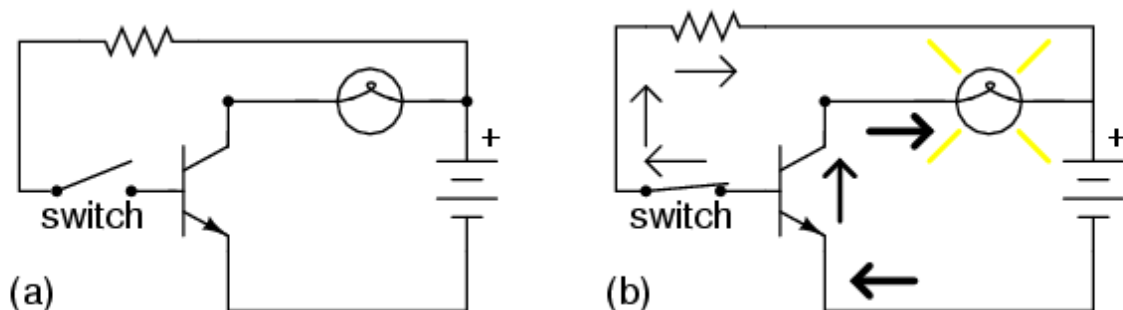

Fig. 3. Transistor as a Switch

1.3. Solenoid

A solenoid is a long piece of wire which is wound in the shape of a coil. When the electric current passes through the coil it creates a relatively uniform magnetic field inside the coil. The solenoid can create a magnetic field from electric current and this magnetic field can be used to generate a linear motion with the help of a metal core. This simple device can be used as an electromagnet, as an inductor or as a miniature wireless receiving antenna in a circuit.

The solenoid simply works on the principle of “electromagnetism”. When the current flow through the coil magnetic field is generated in it, if a metal core is placed inside the coil the magnetic lines of flux is concentrated on the core which increases the induction of the coil as compared to the air core. The magnetic strength of the solenoid can be increased by increasing the density of the turns or by increasing the current flow in the coil.

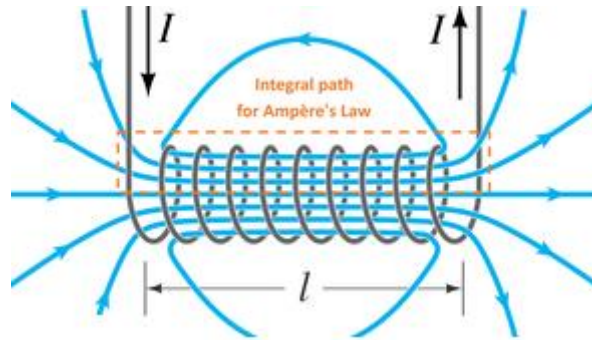

Fig.4. Solenoid

1.4. Electric motor

DC motor

A DC Motor is a machine which converts electrical energy into Mechanical energy. It works on the principle of Lorentz Law, which states that “the current-carrying conductor placed in a magnetic and electric field experience a force”. The experienced force is called the Lorentz force. The Fleming left-hand rule gives the direction of the force.

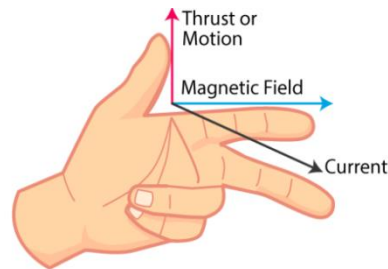

Fig.5. Fleming left-hand rule

Working principle: The principle of operation of a dc motor can be stated as when a current carrying conductor is placed in a magnetic field; it experiences a mechanical force. In a practical dc motor, the field winding produces the required magnetic held while armature conductor play the role of current carrying conductor and hence the armature conductors experience a force.

Types of DC Motors

1. Shunt Motor
2. Series Motor
3. Compound Motor

1.4.1. Shunt motor

A DC shunt motor is a type of self-excited DC motor, and it is also known as a shunt wound DC motor. The field windings in this motor can be connected in parallel to the armature winding. So both windings of this motor will expose to the equal voltage power supply, and this motor maintains an invariable speed with any kind of load. This motor has a low starting torque and also runs at a constant speed.

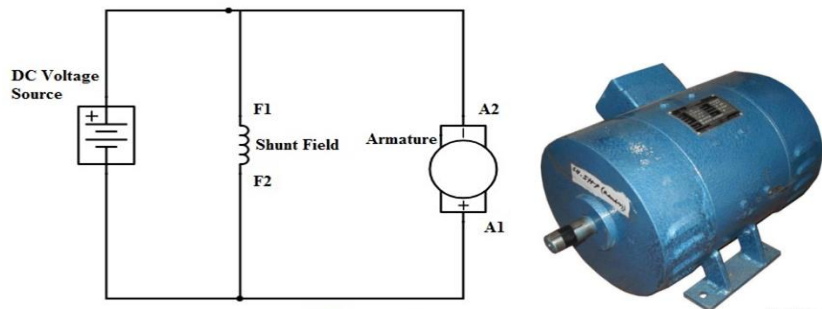

Fig.6. Shunt motor

Characteristics of shunt Motors

1. $T \propto \Phi I_a$ characteristics:

For a constant value of R_{sh} and supply voltage, V , I_{sh} is also constant and hence flux is also constant.

$$T \propto I_a$$

The equation represents a straight line passing through the origin. Torque increases linearly with armature current. It is seen that armature current is decided by the load. So as load increases, armature current increases, increasing the torque developed linearly.

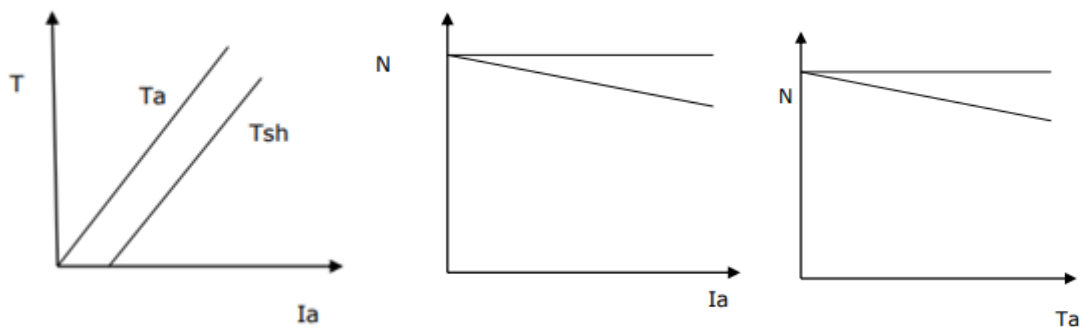

Fig.7. Shunt motor Characteristics

2. N/I_a characteristic:

Φ is assumed constant, then $N \propto E_b$. As E_b is also practically constant, speed is constant. But strictly speaking, both $E_b \times \Phi$ decreases with increasing load. However, E_b decreases slightly more than Φ so that on the whole, there is some decrease in speed.

3. N/Ta characteristics

These can be deduced from the above two characteristics this graph is similar to speed-armature current characteristics as torque is proportional to the armature current. This curve shows that the speed almost remains constant through torque changes from no load to full load conditions.

1.4.2. Series motor

In a series motor electric power is supplied between one end of the series field windings and one end of the armature. When voltage is applied, current flows from power supply terminals through the series winding and armature winding. The large conductors present in the armature and field windings provide the only resistance to the flow of this current. Since these conductors are so large, their resistance is very low.

This causes the motor to draw a large amount of current from the power supply. When the large current begins to flow through the field and armature windings, the coils reach saturation that result in the production of the strongest magnetic field possible. The strength of these magnetic fields provides the armature shafts with the greatest amount of torque possible. The large torque causes the armature to begin to spin with the maximum amount of power and the armature starts to rotate.

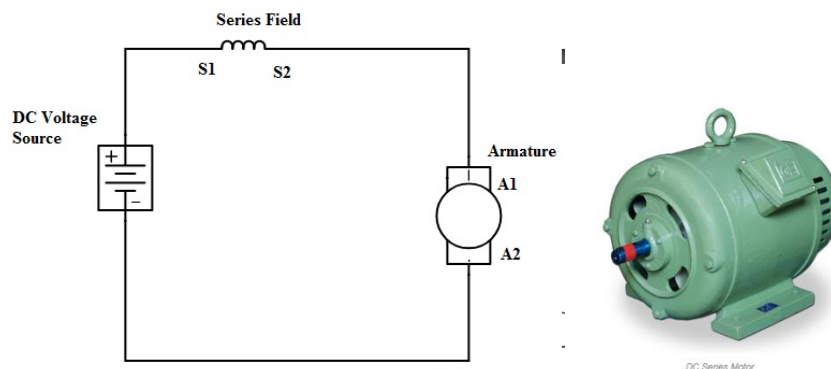

Fig.8.Series motor

Characteristics of series motors

1. Ta/Ia Characteristics.

For series motor $\Phi \propto I_a$

$$T_a \propto \Phi I_a$$

$$\propto I_a^2$$

Thus, torque in case of series motor is proportional to the square of the armature current.

2. N/Ia characteristics

$$N \propto (E_b/\Phi) \propto [v - I_a (R_a + R_{se})/I_a]$$

The values R_a and R_{se} are so small as $\Phi \propto I_a$ in case of series motor that the effect of change in I_a on speed avoid the effect of change in $V - I_a R_a - I_a R_{se}$ on speed change in E_b for various load currents is small and hence may be neglected.

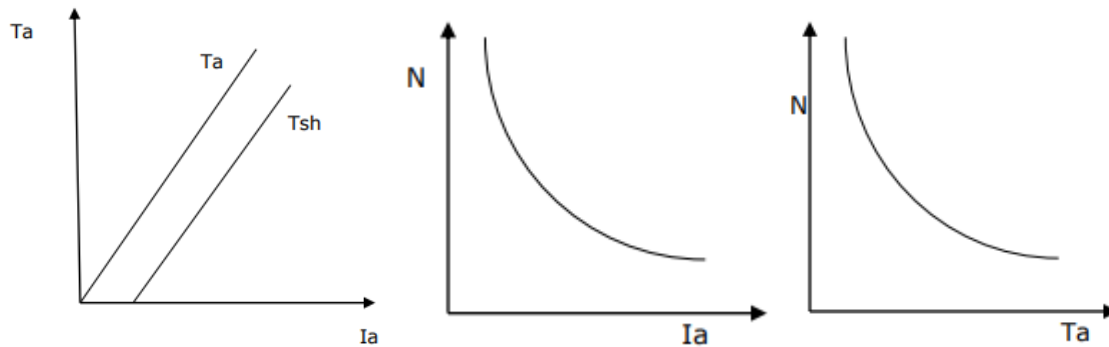

Fig.9. Series motor Characteristics

3. N/I_a characteristics

$$N \propto (E_b/\Phi) \propto [v - I_a (R_a + R_{se})/I_a]$$

The values R_a and R_{se} are so small as $\Phi \propto I_a$ in case of series motor that the effect of change in I_a on speed avoid the effect of change in $V - I_a R_a - I_a R_{se}$ on speed change in E_b for various load currents is small and hence may be neglected.

4. N/T_a characteristic

$$T \propto I_a^2$$

$$N \propto 1/I_a$$

$$I_a \propto \sqrt{T_a}$$

$$N \propto 1/\sqrt{T_a}$$

$$T \propto 1/N^2$$

Thus for small T , speed is large while for large T speed is small.

As I_a increases, torque increases and speed decreases so as torque increases, speed decreases is the nature of this curve, which is similar to speed current curve.

Speed Control of DC Motors

Speed can be controlled by varying:

- 1) Armature circuit resistance using an external resistance $R_{A_{Ext}}$.
- 2) IF can be varied by using an external resistance R_{adj} in series with R_F to control the flux, hence the speed.
- 3) The applied voltage to the armature circuit resistance, if the motor is separately excited. In this motor, field, as well as stator windings, are coupled in series by each other. Accordingly

the armature and field current are equivalent. Use current supply straightly from the supply toward the field windings.

Comparison of DC Motors

Shunt Motors: “Constant speed” motor (speed regulation is very good). Adjustable speed, medium starting torque. ($I_{start} = 1.4 \times I_{FL}$)

Applications: centrifugal pump, machine tools, blowers, fans, reciprocating pumps, etc.

Series Motors: Variable speed motor which changes speed drastically from one load condition to another. It has a high starting torque.

Applications: hoists, electric trains, conveyors, elevators, electric cars, etc.

AC MOTOR

The motor that converts the alternating current into mechanical power by using an electromagnetic induction phenomenon is called an AC motor.

Types of Ac motors:

- 1) Three Phase Induction Motor
- 2) Single Phase Induction Motor

1) Three Phase Induction Motor:

An electrical motor is an electromechanical device that converts electrical energy into mechanical energy. In the case of three-phase AC (Alternating Current) operation, the most widely used motor is a 3 phase induction motor, as this type of motor does not require an additional starting device. These types of motors are known as self-starting induction motors.

A 3 phase induction motor consists of two major parts:

1. A stator
2. A rotor

Stator

The stator of three phase induction motor is made up of numbers of slots to construct a 3 phase winding circuit which we connect with 3 phase AC source. We arrange the three-phase winding in such a manner in the slots that they produce one rotating magnetic field when we switch on the three-phase AC supply source

Rotor

The rotor of three phase induction motor consists of a cylindrical laminated core with parallel slots that can carry conductors. The conductors are heavy copper or aluminum bars fitted in each slot and short-circuited by the end rings. The slots are not exactly made parallel to the

axis of the shaft but are slotted a little skewed because this arrangement reduces magnetic humming noise and can avoid stalling of the motor.

PRINCIPLE OF OPERATION

- ❖ An AC current is applied in the stator armature which generates a flux in the stator magnetic circuit.
- ❖ This flux induces an emf in the conducting bars of rotor as they are “cut” by the flux while the magnet is being moved ($E = BVL$ (Faraday’s Law))
- ❖ A current flows in the rotor circuit due to the induced emf, which in turn produces a force, ($F = BIL$) can be changed to the torque as the output.

In a 3-phase induction motor, the three-phase currents i_a , i_b and i_c , each of equal magnitude, but differing in phase by 120° . Each phase current produces a magnetic flux and there is physical 120° shift between each flux. The total flux in the machine is the sum of the three fluxes. The summation of the three ac fluxes results in a rotating flux, which turns with constant speed and has constant amplitude. Such a magnetic flux produced by balanced three phase currents flowing in three-phase windings is called a **rotating magnetic flux or rotating magnetic field (RMF)**. RMF rotates with a constant speed (Synchronous Speed). Existence of a RMF is an essential condition for the operation of an induction motor.

If stator is energized by an ac current, RMF is generated due to the applied current to the stator winding. This flux produces magnetic field and the field revolves in the air gap between stator and rotor. So, the magnetic field induces a voltage in the short-circuited bars of the rotor. This voltage drives current through the bars. The interaction of the rotating flux and the rotor current generates a force that drives the motor and a torque is developed consequently. The torque is proportional with the flux density and the rotor bar current ($F=BIL$). The motor speed is less than the synchronous speed. The direction of the rotation of the rotor is the same as the direction of the rotation of the revolving magnetic field in the air gap.

However, for these currents to be induced, the speed of the physical rotor and the speed of the rotating magnetic field in the stator must be different, or else the magnetic field will not be moving relative to the rotor conductors and no currents will be induced. If by some chance this happens, the rotor typically slows slightly until a current is re-induced and then the rotor continues as before. This difference between the speed of the rotor and speed of the rotating magnetic field in the stator is called slip. It is unit less and is the ratio between the relative speed of the magnetic field as seen by the rotor the (slip speed) to the speed of the

rotating stator field. Due to this an induction motor is sometimes referred to as an asynchronous machine.

SLIP

The relationship between the supply frequency, f , the number of poles, p , and the synchronous speed (speed of rotating field), n_s is given by

$$n_s = 120 f/p$$

The stator magnetic field (rotating magnetic field) rotates at a speed, n_s , the synchronous speed. If, n = speed of the rotor, the slip, s for an induction motor is defined as

$$s = (n_s - n) / n_s$$

At stand still, rotor does not rotate, $n = 0$, so $s = 1$.

At synchronous speed, $n = n_s$, $s = 0$

There are two types of 3-phase induction motor based on the type of rotor used:

- (i) Squirrel cage induction motor.
- (ii) Slip ring induction motor.

SQUIRREL CAGE ROTOR:

Almost 90 % of induction motors are squirrel-cage type, because this type of rotor has The Rotor consists of cylindrical laminated core with parallel slots for carrying the rotor conductors which, it should be noted clearly, are not wires but consists of heavy bars of copper, aluminium or alloys. One bar is placed in each slot; rather the bars are inserted from the end when semi-enclosed slots are used.

The rotor bars are brazed or electrically welded or bolted to two heavy and stout short circuiting end-rings, thus giving us, what is called a squirrel cage construction. the simplest and most rugged construction imaginable and is almost indestructible.

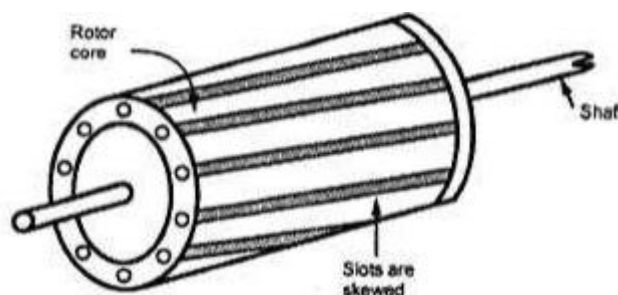

Fig.19. Squirrel cage Induction Motor

SLIP RING INDUCTION MOTOR

In the slip ring motor or wound rotor, an insulated 3-phase winding similar to the stator winding wound for the same number of poles as stator, is placed in the rotor slots. The ends of

the star-connected rotor winding are brought to three slip rings on the shaft so that a connection can be made to it for starting or speed control.

- ❖ It is usually for large 3 phase induction motors.
- ❖ Rotor has a winding the same as stator and the end of each phase is connected to a slip ring.
- ❖ Compared to squirrel cage rotors, wound rotor motors are expensive and require maintenance of the slip rings and brushes, so it is not so common in industry applications.

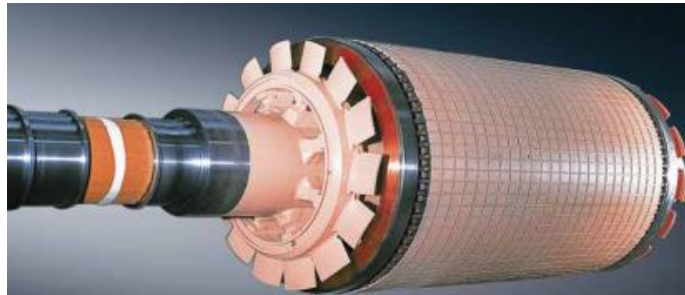

Fig.20. Wound rotor of a large induction motor

STARTING OF 3-PHASE INDUCTION MOTORS

There are two important factors to be considered in starting of induction motors:

1. The starting current drawn from the supply, and
2. The starting torque.

The starting current should be kept low to avoid overheating of motor and excessive voltage drops in the supply network. The starting torque must be about 50 to 100% more than the expected load torque to ensure that the motor runs up in a reasonably short time.

- ❖ At synchronous speed, $s = 0$, and therefore, $\{R_2/s\} = \infty$.so $I_2' = 0$.
- ❖ The stator current therefore comprises only the magnetising current i.e. $I_1 = I_\phi$ and is quite therefore quite small.
- ❖ At low speeds, $\{(R_2'/s) + jX_2\} = \infty$ is small, and therefore I_2' is quite high and consequently I_1 is quite large.
- ❖ Actually the typical starting currents for an induction machine are ~ 5 to 8 times the normal running current.

Hence the starting currents should be reduced. The most usual methods of starting 3 phase induction motors are:

For slip-ring motors

- ❖ Rotor resistance starting

For squirrel-cage motors

- ❖ Direct-on -line starting
- ❖ Star-delta starting
- ❖ Autotransformer starting.

2) Single Phase Induction Motor:

CONSTRUCTION OF SINGLE PHASE INDUCTION MOTOR:

Single phase induction motor is very simple and robust in construction. The stator carries a distributed winding in the slots cut around the inner periphery. The stator conductors have low resistance and they are winding called Starting winding is also mounted on the stator. This winding has high resistance and its embedded deep inside the stator slots, so that they have considerable inductance. The rotor is invariably of the squirrel cage type. In practice, in order to convert temporarily the single phase motor into two-phase motor, auxiliary conductors are placed in the upper layers of stator slots. The auxiliary winding has a centrifugal switch in series with it. The function of the switch is to cut off the starting winding, when the rotor has accelerated to about 75% of its rated speed. In capacitor-start motors, an electrolytic capacitor of suitable capacitance value is also incorporated in the starting winding circuit. The main stator winding and auxiliary (or starting) winding are joined in parallel, and there is an arrangement by which the polarity of only the starting winding can be reversed. This is necessary for changing the direction of rotation of the rotor.

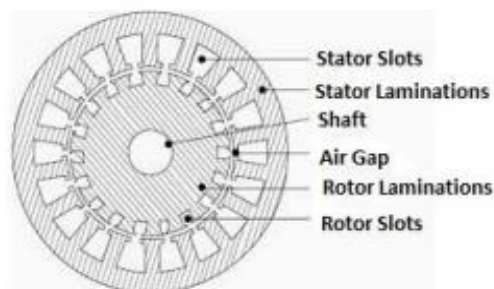

Fig. 21. Single phase induction motor

WORKING OF SINGLE-PHASE INDUCTION MOTOR:

A single phase induction motor is inherently not self-starting can be shown easily. Consider a single phase induction motor whose rotor is at rest. Let a single phase a.c. source be connected to the stator winding (it is assumed that there is no starting winding). Let the stator be wound for two poles. When power supply for the stator is switched on, an alternating current flows through the stator winding. This sets up an alternating flux. This flux crosses the air gap and links with the rotor conductors. By electromagnetic induction

e.m.f.'s are induced in the rotor conductors. Since the rotor forms a closed circuit, currents are induced in the rotor bars. Due to interaction between the rotor induced currents and the stator flux, a torque is produced. It is readily seen that if all rotor conductors in the upper half come under a stator N pole, all rotor conductors in the lower half come under a stator S pole.

Hence the upper half of the rotor is subjected to a torque which tends to rotate it in one direction and the lower half of the rotor is acted upon by an equal torque which tends to rotate it in the opposite direction. The two equal and opposite torques cancel out, with the result that the net driving torque is zero. Hence the rotor remains stationary.

Thus the single phase motor fails to develop starting torque.

The analysis of the single phase motor can be made on the basis of two theories:

- i. Double revolving field theory, and
- ii. Cross field theory.

Double Revolving Field Theory:

This theory makes use of the idea that an alternating uni-axial quantity can be represented by two oppositely-rotating vectors of half magnitude. Accordingly, an alternating sinusoidal flux can be represented by two revolving fluxes, each equal to half the value of the alternating flux and each rotating synchronously ($N_s=120 f/P$) in opposite direction. As shown in fig. (a) let the alternating flux have a maximum value of ϕ_m . Its component fluxes A and B will each equal to $\phi_m/2$ revolving in anti-clockwise and clockwise directions respectively.

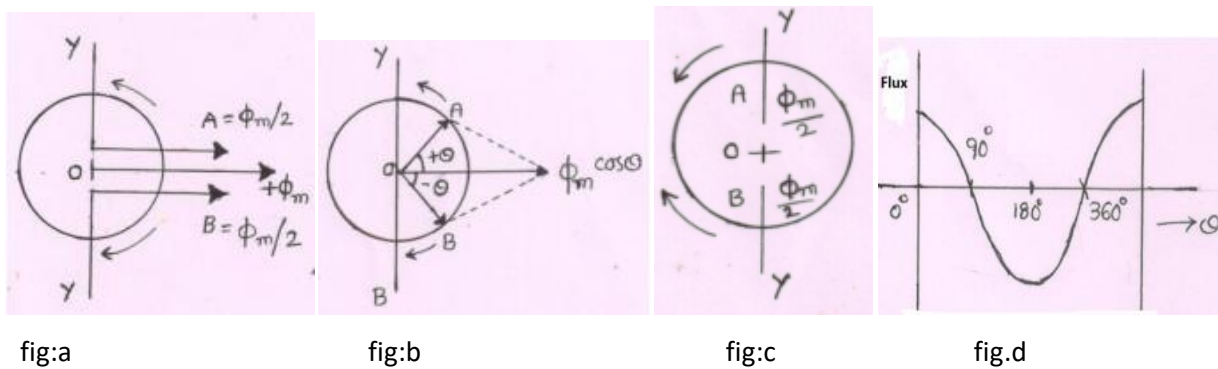

Fig.22. Double revolving field theory

After some time, when A and B would have rotated through angle $+\theta$ and $-\theta$, as in fig (b), the resultant flux would be

$$= 2 * \frac{\phi_m}{2} \cos \frac{2\theta}{2} = \phi_m \cos \theta$$

After a quarter cycle of rotation, fluxes A and B will be oppositely-directed as shown in fig. (c) so that the resultant flux would be zero. After half a cycle, fluxes A and B will have a resultant of $-2 \cdot \phi_m / 2 = -\phi_m$. After three quarters of a cycle, again the resultant is zero and so on. If we plot the values of resultant flux against Θ between limits $\Theta=0$ to $\Theta=360^\circ$, then a curve similar to the one shown in fig. (d) is obtained. That is why an alternating flux can be looked upon as composed of two revolving fluxes, each of half the value and revolving synchronously in opposite directions.

Each of the two component fluxes, while revolving round the stator, cuts the rotor, induces an e.m.f. and this produces its own torque. Obviously, the two torques (called forward and backward torques) are oppositely-directed, so that the net or resultant torques is equal to their difference as shown in fig. 23.

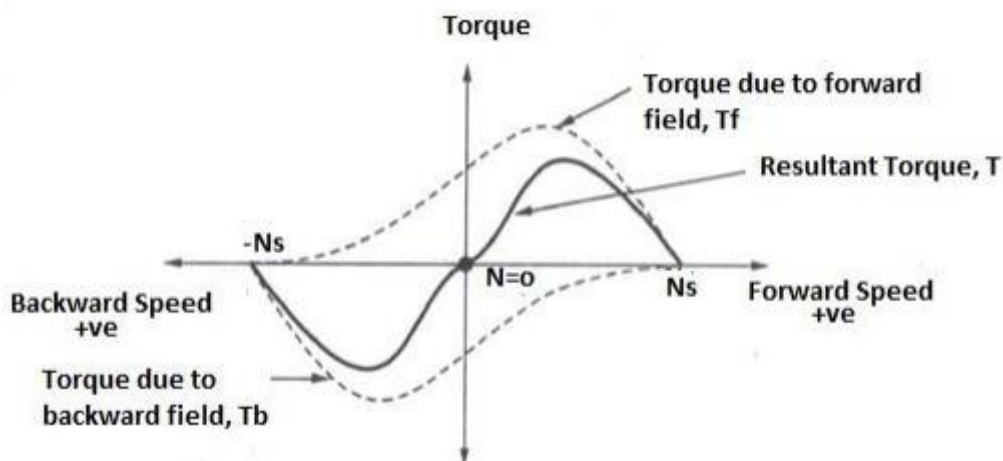

Fig.23. Torque-Speed Characteristics

Synchronous Motor:

Electrical motors are an electro-mechanical device that converts electrical energy to mechanical energy. Based on the type of input we have classified it into single phase and 3 phase motors. The most common type of 3 phase motors are synchronous motors and induction motors. When three-phase electric conductors are placed in certain geometrical positions (i.e. in a certain angle from one another) – an electrical field is generated. The rotating magnetic field rotates at a certain speed known as the synchronous speed

If an electromagnet is present in this rotating magnetic field, the electromagnet is magnetically locked with this rotating magnetic field and rotates with the same speed of rotating field. This is where the term synchronous motor comes from, as the speed of the rotor of the motor is the same as the rotating magnetic field. It is a fixed speed motor because

it has only one speed, which is synchronous speed. This speed is synchronised with the supply frequency. The synchronous speed is given by:

$$N_s = \frac{120f}{p}$$

Construction of synchronous motor

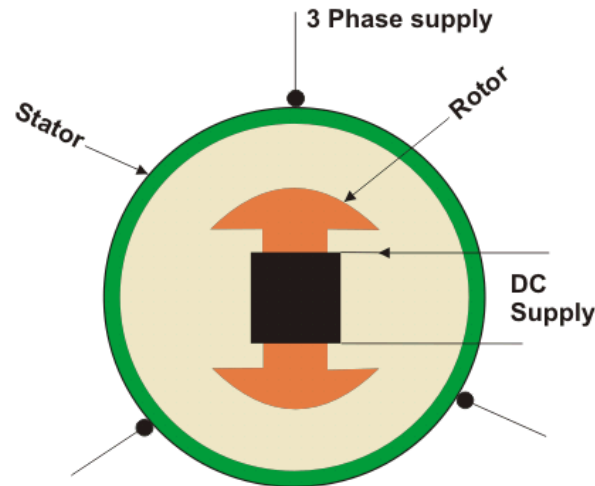

Fig.24. Synchronous motor

Principle of Operation

Synchronous motors are a doubly excited machine, i.e., two electrical inputs are provided to it. A three-phase supply is applied to the three-phase stator winding, and DC to the rotor winding. The 3 phase stator winding carrying 3 phase currents produces 3 phase rotating magnetic flux. The rotor carrying DC supply also produces a constant flux. Considering the 50 Hz power frequency, from the above relation we can see that the 3 phase rotating flux rotates about 3000 revolutions in 1 min or 50 revolutions in 1 sec. At a particular instant rotor and stator poles might be of the same polarity (N-N or S-S) causing a repulsive force on the rotor and the very next instant it will be N-S causing attractive force. But due to the inertia of the rotor, it is unable to rotate in any direction due to that attractive or repulsive force, and the rotor remains in standstill condition.

Hence a synchronous motor is not self-starting. Here we use some mechanical means which initially rotates the rotor in the same direction as the magnetic field to speed very close to synchronous speed. On achieving synchronous speed, magnetic locking occurs, and the synchronous motor continues to rotate even after removal of external mechanical means. But due to the inertia of the rotor, it is unable to rotate in any direction due to that attractive or repulsive force, and the rotor remains in standstill condition. Hence a synchronous motor is not self-starting.

Applications

1. Synchronous motor having no load connected to its shaft is used for power factor improvement. Owing to its characteristics to behave at any electrical power factor, it is used in power system in situations where static capacitors are expensive.
2. Synchronous motor finds application where operating speed is less (around 500 rpm) and high power is required. For power requirement from 35 kW to 2500 KW, the size, weight and cost of the corresponding three phase induction motor is very high. Hence these motors are preferably used. Ex- Reciprocating pump, compressor, rolling mills etc.

Stepper motor

Working Principle

A stepper motor is an electromechanical device which converts electrical pulses into discrete mechanical movements. The shaft or spindle of a stepper motor rotates in discrete step increments when electrical command pulses are applied to it in the proper sequence. The motor's rotation has several direct relationships to these applied input pulses. The sequence of the applied pulses is directly related to the direction of motor shaft's rotation. The speed of the motor shaft's rotation is directly related to the frequency of the input pulses and the length of rotation is directly related to the number of input pulses applied.

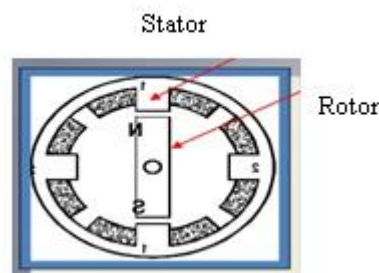

Fig.25. Stepper motor

Stepper motor types by construction:

By construction there are 3 different types of stepper motors: permanent magnet stepper, variable reluctance stepper and hybrid synchronous stepper motor.

The Permanent Magnet stepper has a permanent magnet rotor which is driven by the stator's windings. They create opposite polarity poles compared to the poles of the rotor which propels the rotor.

The next type, the Variable Reluctant stepper motor uses a non-magnetized soft iron rotor. The rotor has teeth that are offset from the stator and as we activate the windings in a particular order the rotor moves respectively so that it has minimum gap between the stator and the teeth of the rotor

The Hybrid Synchronous motor is a combination of the previous two steppers. It has a permanent magnet toothed rotor and also a toothed stator. The rotor has two sections, which are opposite in polarity and their teeth are offset

Operating modes

Stepper motor is a brushless DC motor that rotates in steps. This is very useful because it can be precisely positioned without any feedback sensor, which represents an open-loop controller. The stepper motor consists of a rotor that is generally a permanent magnet and it is surrounded by the windings of the stator. As we activate the windings step by step in a particular order and let a current flow through them they will magnetize the stator and make electromagnetic poles respectively that will cause propulsion to the motor.

The following are the operating modes of a stepper motor:

- a) Full step
- b) Half step
- c) Micro stepping

The magnitude of the step angle of the variable reluctance motor is given as

$$\alpha = \frac{360^\circ}{m_s N_r}$$

Where, α (alpha) is the step angle, m_s is the number of stator phases, N_r is the number of rotor teeth

The step angle is expressed as shown below.

$$\alpha = \frac{N_s - N_r}{N_s N_r} \times 360^\circ$$

N_s is the number of stator poles, N_r is the number of rotor poles

Full step mode

The motor is operated with both phases energized at the same time. Two-phase on provides about 30% to 40% more torque than one phase on, however it requires twice as much power from the driver.

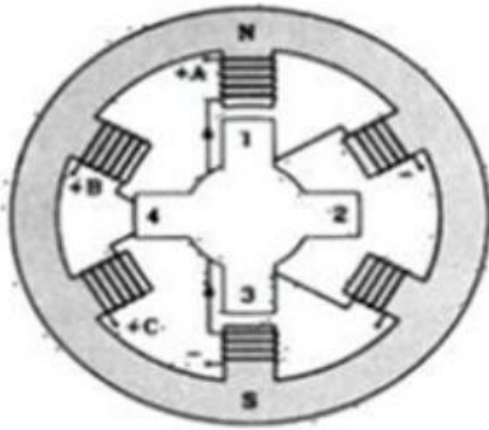

Fig (a)

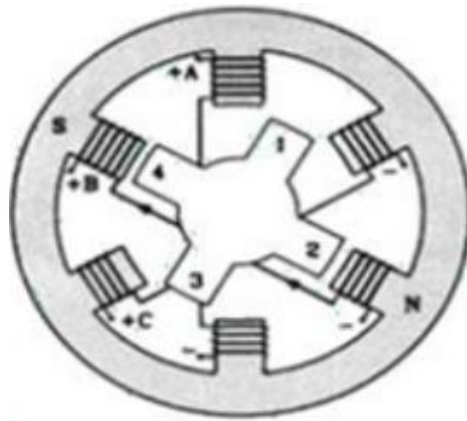

Fig (b)

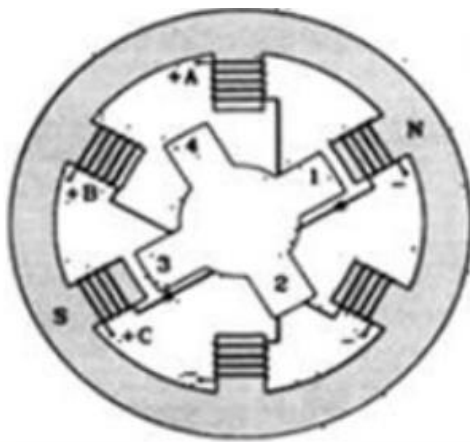

Fig (c)

	A	B	C	θ
A	+	0	0	0^0
B	0	+	0	30^0
C	0	0	+	60^0
A	+	0	0	90^0

Fig (d)

Fig. 28. One phase on Full step mode

	A	B	C	ANGLE		A	B	C	ANGLE
AB	+	+	0	15	A	+	0	0	0
BC	0	+	+	45	AB	+	+	0	15
CA	+	0	+	75	B	0	+	0	30
AB	-	+	0	105	BC	0	+	+	45
					C	0	0	+	60
					CA	+	0	+	75
					A	+	0	0	90

Fig. 29. A) One phase on Full step mode, B) Alternate one phase & two phase on mode half step operation

Micro stepping

Excitation of two phases simultaneously as in two phase on operation, but with one difference. Current in one phase is held constant at its maximum, while the current in the other phase is increased in very small steps till it reaches its maximum. After this, further movement of the rotor is actuated by decreasing the current in the first phase again in very small steps.

Piezoelectric Actuators:

A piezoelectric actuator is an electrically controlled positioning element that functions based on the piezoelectric effect. The direct piezo effect, employed for instance in piezoelectric force sensors, represents generating an electric charge as an effect of mechanical strain. Actuators are based on the reverse effect, namely and electrical field parallel to the direction of polarization determines an elongation of the crystalline material with respect to the same direction. The electrical field generates a torque over the electrical dipoles found in the structure of the material, which will be aligned along the field, producing in turn a change in the length of monocrystalline partitions.

Applications:

- ❖ Fiber alignment switching, splicing and stretching modulation
- ❖ Micro-assembly and micro-handling systems
- ❖ Micro-embossing
- ❖ Laser cavity tuning/stabilization
- ❖ Beam steering/alignment
- ❖ Ultrasonic welding
- ❖ Ultrasonic cleaning

MULTIPLE CHOICE QUESTIONS

1. Which energy is converted into mechanical energy by the hydraulic cylinders?
 - a. hydrostatic energy
 - b. Hydrodynamic energy
 - c. Electrical energy
 - d. None of the above

Answer: a.

2. What is the advantage of using a single acting cylinder?
 - a. High cost and reliable
 - b. Honing inside the inner surface of pump is not required
 - c. Piston seals are not required
 - d. All the above

Answer: c.

3. Which part will surely tell that given motor is DC motor and not an AC type?
 - a) Winding
 - b) Shaft
 - c) Commutator
 - d) Stator

Answer: c

4. Direction of rotation of motor is determined by _____
- a) Faraday's law
 - b) Lenz's law
 - c) Coulomb's law
 - d) Fleming's left-hand rule

Answer: d

5. Starters are used in induction motor because

- a) Its starting torque is high
- b) It is run against heavy load
- c) It cannot run in reverse direction
- d) Its starting current is five times or more than its rated current

Answer d

6. In an induction motor, rotor runs at a speed

- a) Equal to the speed of stator field
- b) Lower than the speed of stator field
- c) Higher than the speed of stator field
- d) Having no relation with the speed of stator field

Answer b

7. The main purpose of a control valve positioner is to:

- (A) Alter the fail-safe status of the valve
- (B) Improve the precision of the valve
- (C) Eliminate cavitations in the valve
- (D) Increase transmitter accuracy

Answer : B

8. What happens to the magnetic field in the solenoid when the current increases?

- a) Increases
- b) Decreases
- c) Remains constant
- d) Becomes zero

Answer: a

9. Rotor resistance speed control method is not applicable in

- a) Slip Ring induction motor
- b) Squirrel cage induction motor
- c) Synchronous motor
- d) None of the above

Answer b.

10. What is the ratio of rotor input power to rotor copper loss in an induction motor?

- a) $1/(1 - S)$
- b) $1 - S$
- c) $1/S$
- d) S

Answer c.

11. Which of these actions does a hydraulic cylinder perform?

- a. Pushing
- b. Lifting
- c. Both a and b
- d. None of the above

Answer: c.

Assignment

- 1) How do hydraulic actuators differ from pneumatic actuators?
- 2) What is the function of a pneumatic cylinder?
- 3) Explain the working of double acting double rod cylinder with a neat sketch
- 4) Discuss the construction, advantages and disadvantages of a double-seated control valve.
- 5) Distinguish between the terms- ideal characteristics and effective characteristics.
- 6) Write short notes on a) DC motor b) AC motor
- 7) Describe stepper motor with neat diagrams

UNIT IV MICRO SENSORS AND MICRO ACTUATORS

Micro Sensors: Principles and examples, Force and pressure micro sensors, position and speed micro sensors, acceleration micro sensors, chemical sensors, biosensors, temperature micro sensors and flow micro sensors.

Micro Actuators: Actuation principle, shape memory effects-one way, two way and pseudo elasticity. Types of micro actuators- Electrostatic, Magnetic, Fluidic, Inverse piezo effect, other principles

Micro sensors - Introduction

Presently, there is a trend to make sensors smaller and smaller. Initial stages show an evolution from a single sensor element to an intelligent sensor system with extremely small dimensions by MST. The so-called smart (or integrated) sensing devices can be developed by integrating sensor components with those for signal processing. This integration also decreases the noise that is often created by the transmission of signals to an external data processing unit. Thus it will be possible to measure and evaluate for a certain task all interesting parameters at one place and at one time. An important step toward the further development of micro sensors is the conception and design of intelligent electronic signal processors. This will lead to advanced distributed sensor systems in which noisy sensor signals, resulting from cross-talk or insufficient selectivity, can be successfully evaluated. The signal processing system of humans is very advanced; sensor signals are received over the nervous system and transferred to the brain which reliably evaluates them by a natural parallel computing system

Force and Pressure Micro sensors

Due to their simple construction and wide applicability, mechanical sensors play the most important part in MST. Pressure micro sensors were the first ones developed and used by industry. Miniaturized pressure sensors must be inexpensive and have a high resolution, accuracy, linearity and stability. Presently, silicon-based pressure sensors are most often used; they can easily be integrated with their signal processing electronics on one chip. Their advantages include low production costs, high sensitivity and low hysteresis.

Pressure is most often measured via a thin membrane which deflects when pressure is applied. Either the deflection of the membrane or its change in resonance frequency is measured; both of these values are proportional to the pressure applied. These mechanical changes are transformed into electric signals. Membranes can be manufactured by bulk

micromachining of a (100) silicon substrate, whereby the membrane is produced with one of the etch stop techniques. Pressure sensors usually employ capacitive or piezo resistive measuring principles.

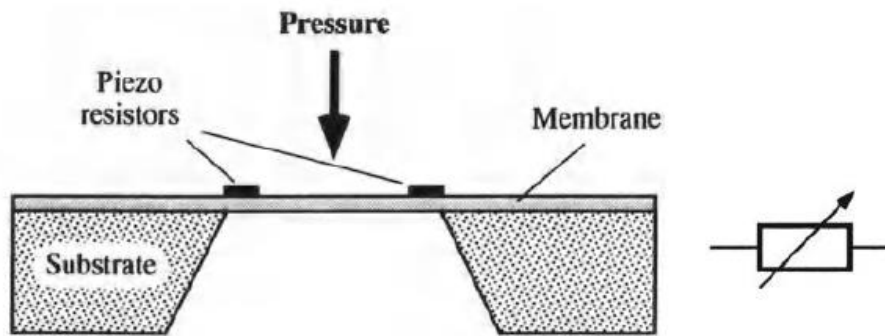

Fig. 1. Piezo resistive pressure sensor

Fig.1. shows the design of a piezo resistive pressure sensor. The piezo resistors are integrated in the membrane; they change their resistance proportionally to the applied pressure. The resistance change indicates how far the membrane is deflected and is measured with a Wheatstone bridge. The deflection value is proportional to the pressure.

Capacitive pressure sensor

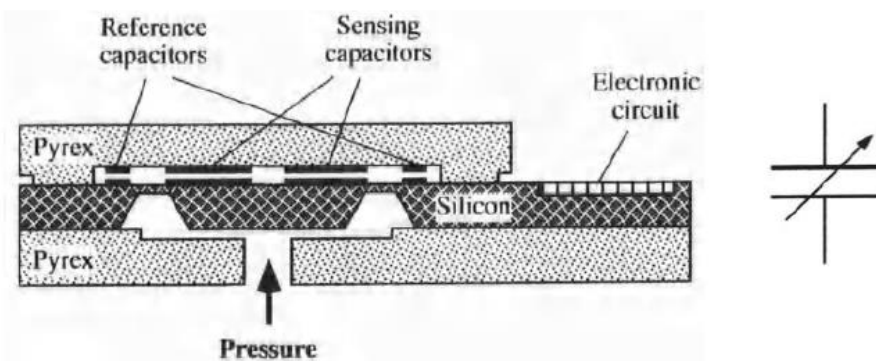

Fig.2. Capacitive pressure sensors

Capacitive sensors make use of the change of the capacitance between two metal plates. The membrane deflects when pressure is applied, which causes the distance between the two electrodes to be changed. Through this the capacitance increases or decreases. From the amount of membrane deflection the capacitance change is measured and the pressure value can be calculated.

A capacitive sensor is shown in Fig.2. The electrodes are made up of a planar comb structure. Here, the applied force is exerted parallel to the sensor surface. In force sensors which use membranes, the force is usually applied perpendicular to the sensor surface. Here,

nonlinearity and cross-sensitivity may cause problems. In the device described here, the sensor element mainly consists of two parts: first, a movable elastic structure which transforms a force into a displacement, and second, a transformation unit consisting of the electrodes which transform the displacement into a measurable change of capacitance.

Capacitive force sensor made of silicon.

The displacement is restored by an elastic suspension beam. The capacitors consist of two electrically insulated thin electrodes with a very narrow gap between them (approximately 10 μ m). They are placed on both sides of the sensor chip, making the capacitance on one side increase and decrease on the other side. By the separate measurement of the capacitance changes on both sides a high linearity and sensitivity is obtained. The sensor unit is made by anisotropically etching (110) silicon and then fastening it to a pyrex substrate through anodic bonding. The prototype of the capacitive micro sensor had a nominal capacitance of 1 pF. Measurements in this range can easily be handled by commercially available microelectronic measuring devices. It was possible to measure very small forces with a resolution of 20 nm (0.01-10 N). The same structure can be used as a positioning unit for nanorobots.

A force sensing resistor

A new measurement principle was realized by using a so-called force sensing resistor. The device is fundamentally different from capacitive, piezo resistive and resonant sensors, since here the resistance is inversely proportional to the pressure. The sensor consists of a polymer foil to which planar electrodes are fastened, on top of this a semiconductor polymer film is placed, Fig. 6.10. If a voltage is applied to the electrodes and there is no force, the resistance is at least 1 M Ω . When a force is applied, the resistance decreases due to current that flows across the shunting polymer foil.

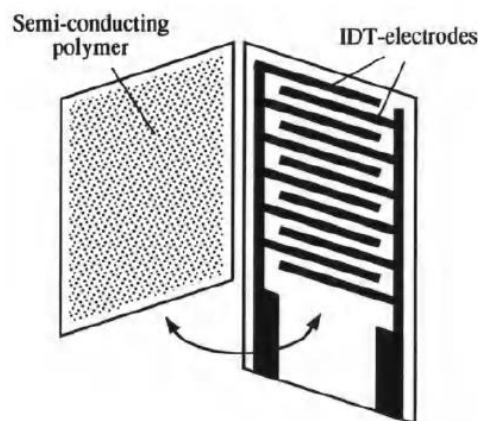

Fig. 3. A force sensing resistor

The dynamic range of the sensor can be influenced by producing a finer electrode structure. This, however, is accompanied by increasing production costs due to a lower yield rate. The sensitivity can be increased by varying the foil thickness. The device can be operated at temperatures of up to 400°C and is very durable, e.g. over 10 million repeated measurements were made with a 5% deviation. The measurement range is between 10 g and 10 kg. A major disadvantage is the hysteresis, which appears during pressure changes. Despite of this fact, the device can be usefully employed for many dynamic measuring applications. It is inexpensive, compact, robust and resistant to external influences.

Ultrasound distance sensors

Ultrasound distance sensors are well suited as position sensors for micro robots, since they do not depend on the optical properties of the object being detected and they are robust and can obtain reproducible results. Ultrasound distance sensors use the pulse-echo principle. Here a pulse sequence is emitted with the help of an ultrasound transducer which is usually made from piezo ceramics. The signals reflected by objects as echos are received by a sensor and evaluated using the propagation time of the sound signal.

Since the transducer needs some time for recovery after transmission; a "blind spot" appears when the detector is too close to an object, which means that an object might not be detected. The results obtained with a new concept of an ultrasound micro transformer were reported in (M2S293).

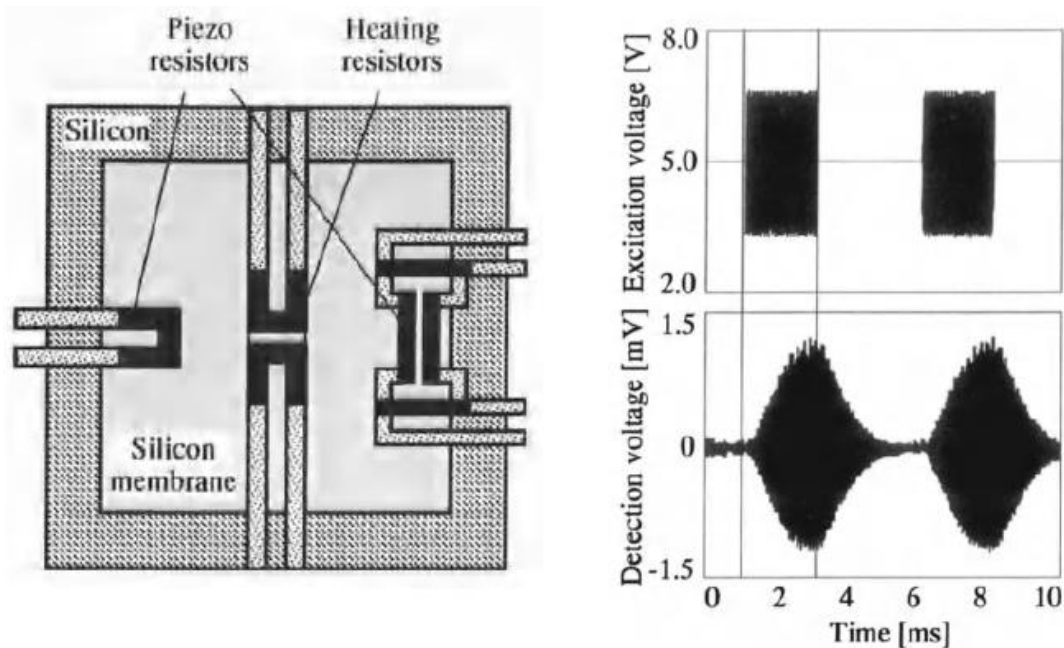

Fig. 4. Ultrasound distance micro sensor

In this device, two identical independent ultrasound membranes were integrated next to each other on a silicon substrate; one served as a transmitter and the other one as a receiver. The schematic design of a single sensor membrane and the measurement principle are shown.

The transmitter membrane is brought to resonance electro thermally with integrated heating resistors. The acoustic pressure response is then detected by piezo resistors, integrated in the form of a Wheatstone bridge in the receiver membrane. The sensitivity of this prototype was about 3 uV/mPa at a bridge voltage of 5V.

Capacitive rotational speed sensor

In many technical systems like navigation and landing gear controllers, compact and inexpensive angular speed sensors are required. Conventional sensors using piezoelectric resonators or optical glass fibers are very sensitive, but are usually expensive. The following described silicon sensor was produced using a batch fabrication method [Hash94]. The operating principle of the resonating sensor is presented in Fig.5.

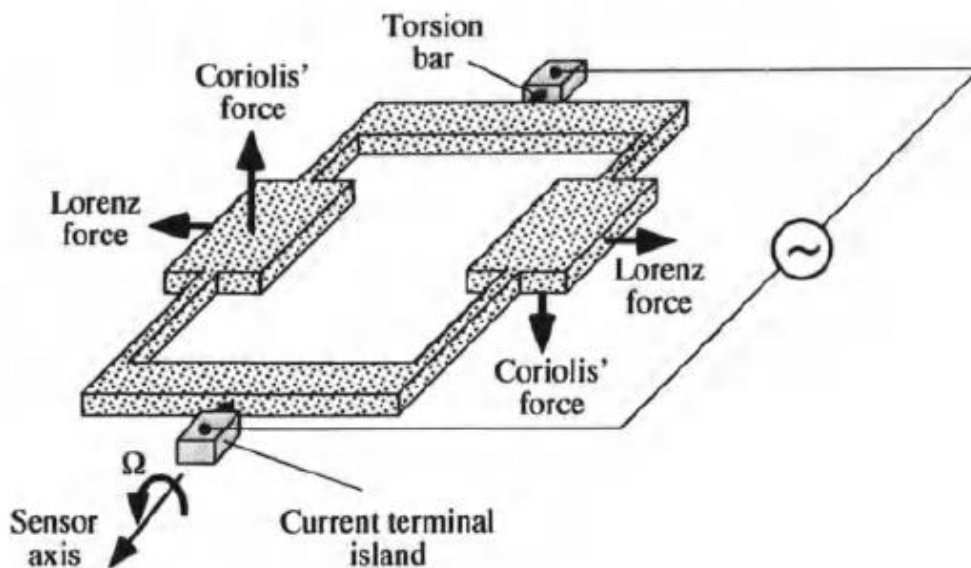

Fig.5. Operating principle of a rotational speed micro sensor

A 200um thick tuning fork arrangement made of (110) silicon is used as the resonator. It is positioned by two torsion bars which also serve as electrical terminals. When the resonator is introduced into a magnetic field and alternating current is applied it starts to oscillate due to Lorentz forces. If the sensor rotates at ω degrees about its longitudinal axis, the Coriolis forces induce a rotational movement in the opposite direction about this axis; this movement is proportional to the swing angle ω . The amplitude of the swing is

detected by the capacitance change between the fork prongs (movable electrodes) and the fixed detection electrodes, not shown in Figure 6.17. The latter are integrated into a glass casing consisting of two pyrex glass layers, each 250 μm thick. A sensor prototype with a base area of 2 cm x 2 cm was built; it had a sensitivity of 0.5 mVsec/deg at an exciting frequency of 470 Hz.

Acceleration Micro sensors

Cantilever principle

Miniaturized acceleration sensors will mostly find their place in the automotive industry. They are also of interest to the air and space industries and for many other applications. Acceleration micro sensors will help to improve the comfort, safety and driving quality of automobiles. However, in order for them to become a product of general interest, their production costs must be drastically lowered. As with pressure (Fig. 6 and Fig. 7), acceleration is usually detected by piezo resistive or capacitive methods. Mostly an elastic cantilever is used to which a mass is attached. When the sensor is accelerated the mass displaces the cantilever and the displacement is picked up by a sensor. Such a sensor is shown in Fig. 6. It uses the capacitive measuring method to record deflection. From the deflection the acceleration can be calculated.

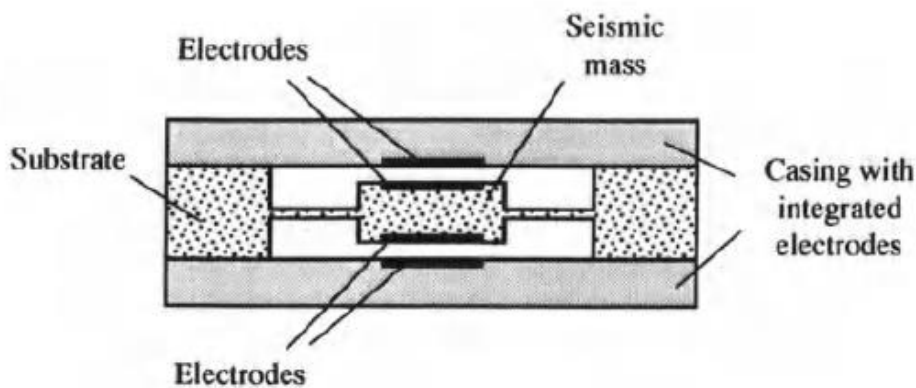

Fig.6. Capacitive measurement of accelerations

Piezo resistive principle

To effectively measure acceleration with this principle, piezo resistors are placed at points of the cantilever where the largest deformation takes place. The stability and accuracy of the sensor improves with increasing number of piezo elements. If a mass moves due to acceleration, it deforms the piezo resistors, thereby changing their resistance, in fig.7. The acceleration is determined from the resistance change.

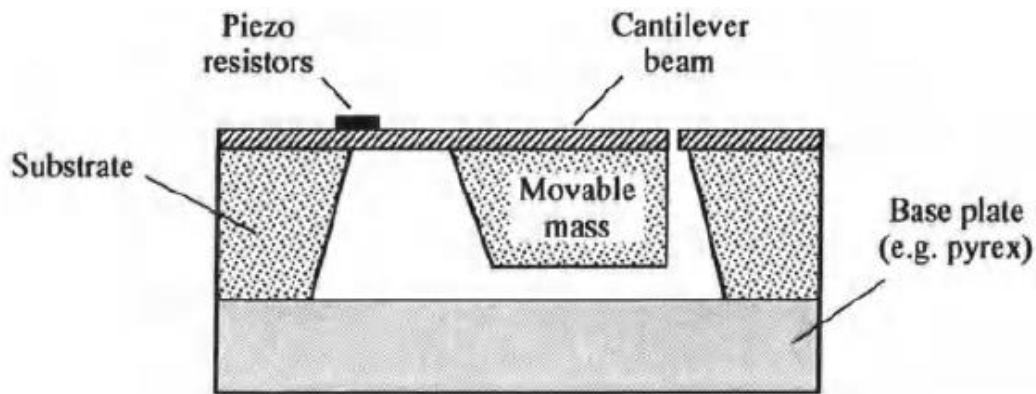

Fig.7 Piezo resistive principle for acceleration measurement

By increasing the movable mass the sensitivity of the sensor will be improved. The mass's center of gravity should be as close to the end of the cantilever as possible. Piezo resistive acceleration micro sensors are usually produced using the silicon technology. This allows the microelectronic processing unit to be integrated onto the sensor chip, making the system compact and robust.

Capacitive cantilever micro sensor

An acceleration sensor produced by the surface micromachining technique was described in [Fricke93]. A sketch of this sensor is shown in Figure .The sensor consists of one or more cantilevers acting as one electrode; they are suspended freely over an opposite electrode and a contact strip. There is only a small gap between the cantilever and the electrode to maximize the electrostatic forces and to keep the mechanical stresses as small as possible.

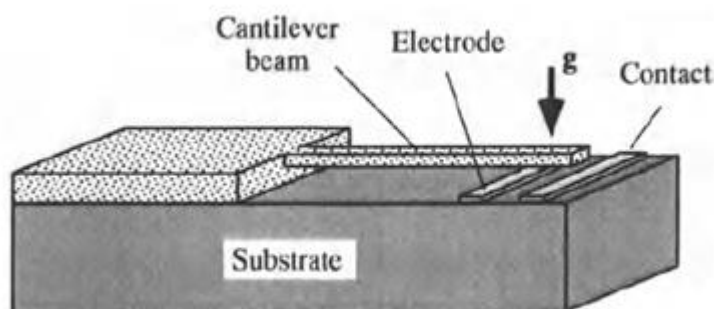

Fig. 8. Capacitive cantilever acceleration micro sensor

As opposed to conventional capacitive sensors, a so-called threshold voltage is applied to offset the forces caused by the acceleration; it will give an indication of the current acceleration. With this device, a saw tooth voltage is applied in defined steps across the

cantilever and the electrode, which gradually increases the electrostatic force acting on the cantilever. When the critical voltage is reached, the system becomes unstable and the cantilever bends towards the contacts and finally touches them. The voltage falls to zero, and the saw tooth voltage is applied again. The actual value of the threshold voltage to be applied depends on the magnitude of the acceleration.

Chemical Sensors

Chemical sensors detect the presence or concentration of a chemical substance in a solution. They may be used for qualitative and quantitative measurements. In medical diagnostics, nutritional science, environmental protection and the automobile industry, many different chemical quantities are to be measured.

About 60% of all chemical sensors are gas sensors. The rest is used to detect substances and concentrations in liquids. An important application potential of chemical sensors is in environmental protection, medical applications and process engineering. Many industrial countries will soon be adopting very strict environmental standards and laws that will rapidly increase the demand for gas and liquid sensors. Present research is concentrated on the integration of these sensors in measurement systems.

The potentiometer principle in connection with field effect transistors (FET), acoustic sensors using the change of mass principle and optical sensors are most often applied. Many gas and liquid sensors are based on these principles and have similar structures. It is usually very important for chemical sensors to have a low cross-sensitivity, i.e. the measured values are not influenced significantly by other substances in the solution being analyzed. For measuring chemical substances, a sensitive layer or a specific area of the sensor is used to contact the chemical substance.

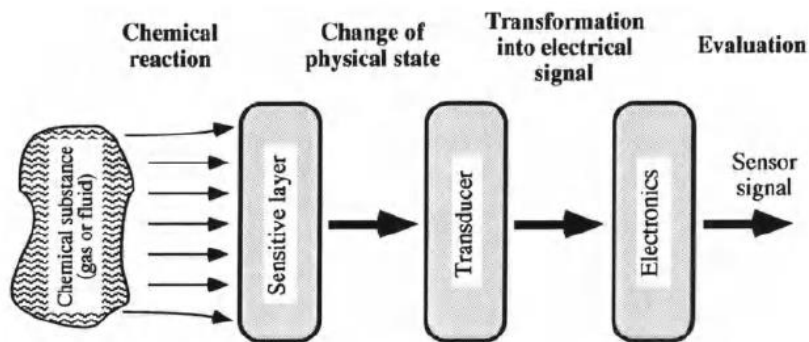

Fig.9. General Structure of chemical sensors

During measurements, a chemical reaction occurs on this sensitive layer/area and a transducer, of which the physical, optical, acoustical or dielectric properties are changed, transforms the recorded phenomenon into an electric signal. This signal is then amplified and evaluated by a microelectronic component. The general structure of a chemical sensor system is shown in Fig.9.

Field effect transistor sensor principle

Ion-sensitive field effect transistors are used to measure the concentration of ions of various elements such as hydrogen, sodium, potassium or calcium. The structure of an ion sensitive FET and its measurement principle can be seen in Figure.

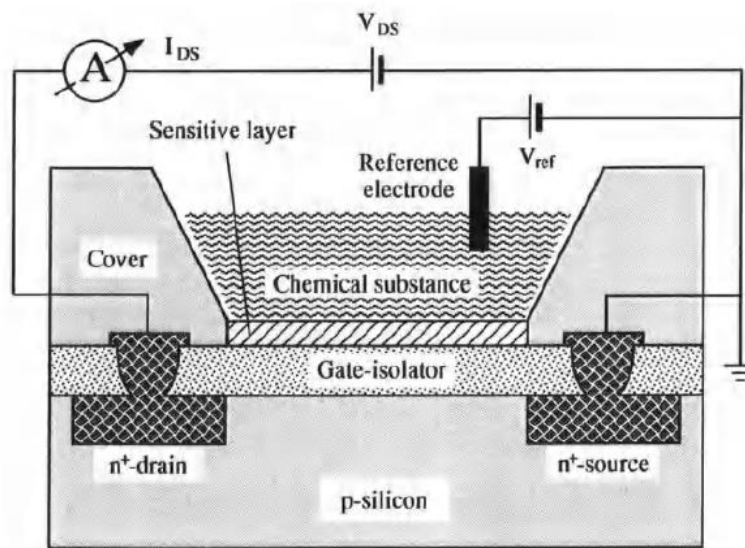

Fig.10. Chemical sensor

Initially, when no chemical substance is in contact with the ion-sensitive layer deposited on the gate area of the transistor, the gate potential V_{gs} is equal to V_{ref} . When the substance to be measured contacts the ion-sensitive layer, the gate potential V_{gs} changes; this voltage change is caused by the ions in the chemical substance. Thereby, the current I_{DS} between the source and drain changes as well. The gate potential V_{gs} is then corrected by adjusting the voltage V_{ref} until the original transistor current I_{DS} flows again; the voltage V_{DS} is held constant. The value ΔV_{ref} is proportional to the ion concentration of the analyzed substance to be measured, Fig. 10. The area of the sensitive layer can be as small as a few μm^2 , allowing very small amounts of substance to be measured.

Biosensors

However, in a biosensor the biologically sensitive elements such as enzymes, receptors and antibodies are integrated with the sensor. The interaction between the protein molecules of the bio element and the molecules of the substance causes a modulation of a physical or chemical parameter. This modulation is converted into an electrical signal by a suitable transducer. The signal represents the concentration to be measured. In many molecular interactions, gases are either released or consumed, e.g. the change of oxygen can be registered by a chemical O₂ sensor. Very selective and sensitive measurements are possible with biological receptors.

There are many applications for miniaturized biosensors. In biological and nutritional research, these sensors are extremely important to analyze trace elements, especially when toxic substances like heavy metals or allergens have to be found. Considering that there are more than 5 million different inorganic and organic compounds known today, and that 100,000 different substances can be identified, it is getting clear that there is an enormous need for such small, inexpensive and reliable biosensors.

Also in medicine, where a variety of substances are to be monitored during surgery or during an *in-situ* investigation, an increasing number of small biosensors will be used to record vital patient data for a correct and quick diagnosis. Biosensors are divided into two groups. They are metabolism sensors and immuno-sensors. A metabolism sensor uses bio sensitive enzymes as biocatalysts to detect molecules in a substance and to catalyze a chemical reaction. The analyzed substance is chemically transformed and the course of a reaction can be detected and evaluated by a chemical sensor indicating the concentration of the substance in a solution.

This mechanism is illustrated in Figure with an example of an enzyme based measurement of phosphate in waste water treatment. The enzyme nucleoside phosphorylase (NP) is used to determine the phosphate content. This enzyme detects the phosphate and triggers a chemical reaction when inosine is added. One product of this reaction is hypoxanthine (HX). This substance then takes part in another chemical reaction and is transformed into xanthine oxidase (XO) after consuming oxygen. The amount of oxygen consumed can be registered with a chemical O₂ sensor and the phosphate concentration can be determined from this.

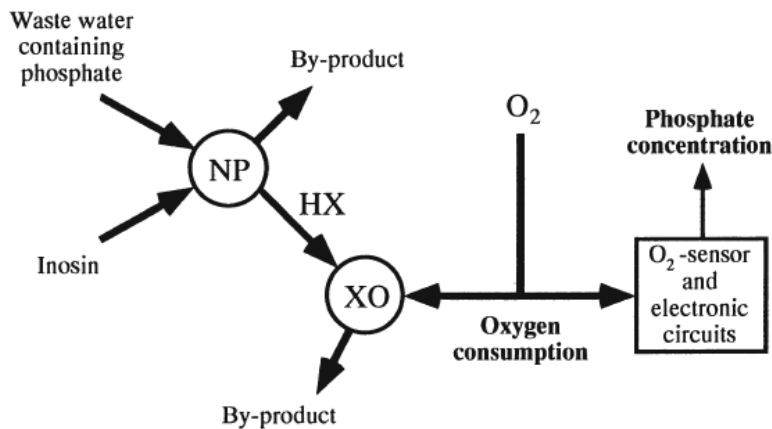

Fig.11 Phosphate measurement with metabolism sensor

To detect chemically inactive molecules in a substance, immuno-sensors are used; their bio sensitive elements are antibodies. The detection method for an antigen molecule is known as the lock and key principle. When it interacts with the analyzed substance, immobilized antibody molecules ("lock") on the sensor surface bond with an antigen molecule "key" in the substance. No other molecule can bond with these antibodies.

The bonding process can either be directly registered over a transducer or indirectly through antigen markers, e.g. using molecules of another substance; depending on the type of sensor. From this measurement the concentration can then be determined. The sensor in Fig.12 detects the concentration of the antigens directly with an interferometric method. The light intensity changes are here due to the bonding process. An attempt is being made to integrate biosensors into Microsystems to take advantage of the many functions they offer. The integration of biosensors with micro pumps and micro valves would make it possible to manufacture very small measuring systems that only need small samples and can measure quickly.

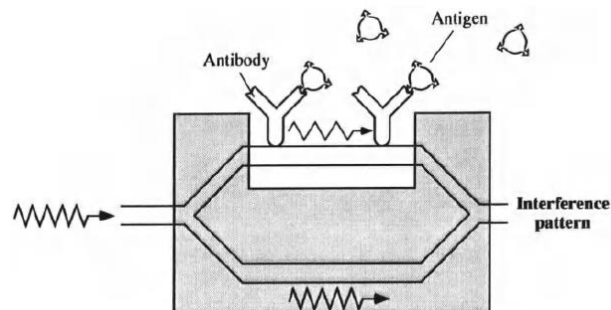

Fig. 12. Immuno sensing using an optical transducer

One difficulty encountered, however, is that a system integration of biosensors may produce only short-lived sensors because the proteins are not very stable for a very long time. Another problem to date is the immobilization of the proteins. Now, some practical developments in the area of miniaturized biosensors will be introduced.

Temperature Sensors

Temperature sensors play an important role in different types of monitoring systems, especially in process, medicine and environmental protection technologies. They are also indispensable for controlling beatings or air conditioning systems and many household appliances. A temperature value may also be a parameter of indirect measurements of other parameters in gas or flow sensors or it may be used for error compensation of temperature-dependent sensors and actuators. There is a wide range of conventional temperature sensors available, like the thermo element, thermo resistor, thermo diode, etc. The next examples describe the development of miniaturized temperature sensors.

Fiber optical thermometer

Several glass fiber thermometers were described in Fig.13 shows a simplified temperature sensor. The sensor contains a light source, a glass fiber, serving both as waveguide and temperature sensor, and a photodiode. The multi-modal glass fiber is made of materials that have different temperature coefficients in the core and the mantle (quartz-silicon system).The light is introduced by an LED into the glass fiber and is propagated through the sensitive fiber area. When the temperature varies in the sensor surrounding, the local index of refraction in the fiber changes, which results in an optical light attenuation.

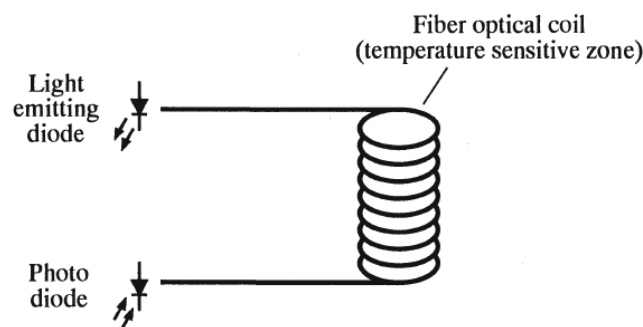

Fig.13. Fiber optic thermometer

This, in turn, leads to a change in the intensity of light leaving the thermometer; the change of light is measured by the photodiode. This measurement can be used to calculate the temperature. A prototype of this sensor has been used for a long time. It can measure

temperatures of up to 90°C with an accuracy of 0.1 oc. The thermometer is insensitive to electromagnetic noise, it costs about seven dollars.

Flow Sensors

There is a need for miniaturized sensors to measure very small liquid and gas flows, since in many applications, like in medical instruments and automobiles, micro fluidic components are becoming an indispensable part of a system. Most of these sensors operate on the principle of thermal energy loss, which occurs when the heating element is located in a flowing substance (thermal dilution). Also, transit time measurements of a trace element injected into the flow can be used to determine a velocity. Another measurement principle uses the forces or torques exerted on an object which is placed in the fluid flow.

Two-mode flow sensor

A flow sensor was shown which can be operated in two modes. A sketch of this sensor is depicted in Fig14. In one mode, the sensor uses the elapsed time of the locally heated flow medium. A 5 Hz signal was applied to the heater and the time was measured until the temperature rise is recorded downstream by the sensor. In the second mode (thermal dilution),the heater was supplied with constant energy and the temperature difference between the upstream and downstream sensors was measured. The highest sensitivity registered was in the range of 0.05-0.2 ml/min. One disadvantage of this method would be a possible change in the liquid property due to the heat impulses.

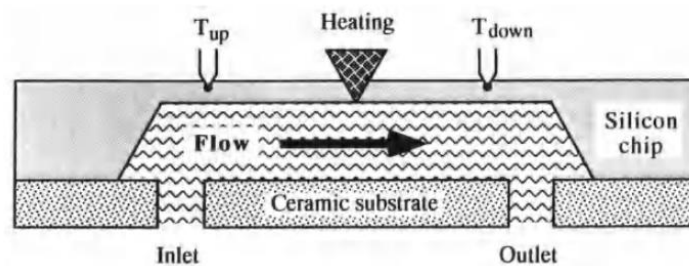

Fig.14. Flow sensor

The device was made to measure both liquid and gas flows. It has two temperature sensors, one in front of the heating element and one behind it. Here, the thermal energy loss between the two temperature sensors was measured. All components of the flow sensor are integrated into one silicon chip. The flow channel is 7 mm long, 1.3 mm wide and 350 um high; it was made by the bulk micromachining technique. Both the inlet and outlet opening have a diameter of 0.7 mm. The silicon membrane is 40um thick.

Thermal flow sensor

A sensor which uses a thermal measurement principle for recording gas flows was developed and shown. A schematic diagram of the sensor is shown in Fig.15. The sensor has a circular silicon disc into which a heating resistor is implanted. The center of the chip is in contact with the gas and serves as a heating element. There is a ring-like silicon dioxide layer around the disc, which guarantees good thermal insulation between the hot and cold sensor parts. The chip cover was made of a 3 μ m thick polyimide film. The flow speed is determined from the thermal interaction between the hot silicon and the gas. Two diodes are implanted into the silicon chip using a CMOS process (not shown in the diagram). They are the thermometers to measure the temperature difference of the gas at the heating element and at a fixed point downstream.

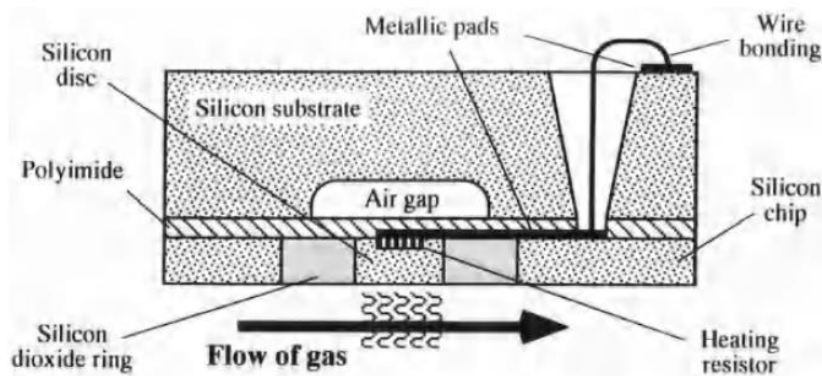

Fig.15. Thermal flow sensor

Several prototypes with an overall dimension of 5 mm x 5 mm were produced. The heating membranes had a diameter between 75 μ m and 500 μ m; the membrane and SiO₂ layer thicknesses were 15 μ m and 30 μ m, respectively. The measured results agreed with the theoretically calculated values up to a flow speed of 2.5 m/s. The sensor sensitivity was 10 cm/s. The development of new chemical, physical and biological sensors is a continuous process. Only a small sample of existing sensors could be covered here. A detailed description of current research in this area is given in[Gard94]. Numerous sensor principles had been developed in a variety of forms. The manufacturing technology of semiconductors and thin-films will probably play the largest role in the future to make the sensors and to integrate them with the control circuits on one chip.

Micro actuators:

Principles and Examples

Introduction

The MST applications suggest the use of new micro actuator systems which allow motions to be realized with micrometer accuracy. Conventional motion concepts or manufacturing methods are no longer able to fulfil the demands concerning miniaturization and all questions connected with it. Microsystems, and in particular future micro robots, require the development of new advanced actuators with very small dimensions, simple mechanical construction and high reliability.

It is rather difficult to determine exactly what the name "micro actuator" implies. In the literature, the term "micro actuators" is used for devices ranging in size from micrometers to several decimeters, proving the typical classification difficulties of this young scientific field. This book considers a micro actuator as a device of a few micrometers to a few centimetres in size having a functional principle applicable in the micro world.

In addition to the miniaturization, mechanical micro devices having components such as pumps, valves, robot grippers, linear and rotational positioning elements, simple cantilever actuators and complex artificial muscle systems, must be functional to provide a micro system with task-dependent capabilities. Micro pumps and -valves for treating liquids and gasses at the micro level can be applied in medicine, where implantable, highly accurate micro systems are needed for the dosing of medication or for chemical and biotechnological analysis where minute volumes of liquid must be transported and measured. They can also be applied for technical devices such as ink jet printers.

Micro actuators using the cantilever principle can be applied for various applications to generate minute motions. In optics such micro actuators can serve as electronically tuneable mirrors, in fluid dynamics as valves, and in micro robotics as grippers. Micro motors also have a great potential for MST applications.

Actuation Principles

Functional properties of actuators are determined above all by the underlying actuation principles. The forces and displacements that can actually be reached for a certain component size depend on the scaling behaviour, actuator design, and technical limits. Therefore, the total dimensions of an actuator determine which actuation principle is best

suited for a given application. The scaling behaviour of the forces is derived from the force laws by introducing a scaling variable r , which describes the component size in any spatial direction. In analogy, the scaling behaviour of work and power density can be determined.

Electrostatic Principles

Electrostatic actuators make use of Coulomb's attraction force between oppositely charged bodies. In the simplest case, two charged plates oriented in parallel are available. Apart from the force component F_z that acts vertically between the plates, lateral-plate offset additionally causes a force F_x acting in the lateral direction.

Magnetic Principles

The magnetic principles of force and movement generation can be classified in electrodynamic, reluctance, and electromagnetic principles. Electrodynamic micro actuators make use of the Lorentz force on a conductor passed by a current in a magnetic field. So far, such actuators have hardly been noticed due to their difficult-to-achieve three-dimensional geometry. Contrary to this, the reluctance principle is the most frequently applied magnetic actuation principle in micro technology. Micro technical implementation requires an acceptable effort, since only a single field source and no hard magnetic materials are needed.

Fluidic Principles

Fluidically driven micro pistons allow high testing forces and large displacements to be reached in, e.g., micro tensile testing machines. The force-displacement characteristics exhibit a constant behaviour. The principle of pressure-dependent membrane deflection is applied in a number of micro valve versions. Other fluidic arrangements are based on fluid dynamics principles or electro rheological and magneto rheological principles.

Inverse Piezo effect

Piezoelectric actuators make use of the coupling of mechanical deformation and electric polarization in ferroelectric crystals, in crystals with a triad axis, or in certain polymers. A major class of materials is made up of $\text{Pb}(\text{Zr}_x\text{Ti}_{1-x})\text{O}_3$ (PZT) crystals due to their high coupling factors of about 0.7 and piezoelectric coefficients d_{31} of about 0.5 nm/V .

Shape Memory Effects

The term "shape memory" describes the unusual ability to remember shape, which can be initiated in certain materials either thermally or mechanically. Even after heavy deformation, materials with shape memory are able to recover a previously memorized shape. This phenomenon was discovered in brass alloys as early as the late thirties. However, the real importance of the effect has become obvious only since its discovery in a NiTi alloy, where it is particularly pronounced.

The most important materials of commercial significance can be classified either as metal alloys or as polymers. Furthermore, there are ceramics and biological systems in which shape memory properties are observed as well. An example to be mentioned in this respect is bacteriophages, which use a shape memory mechanism when entering host cells. SMAs are currently the focus of interest, as they have proved to function in a number of applications and show an unforeseeable potential for future applications.

In contrast to conventional structural materials, in which shape changes are made up of elastic, plastic or thermal contributions, SMAs show three additional types of shape changes that are associated with shape memory characteristics. These effects are illustrated in Fig. by the example of a helical spring:

- (a) One-way effect: After removal of the load F , the helical spring shows permanent deformation. This seemingly plastic deformation recedes completely upon heating.
- (b) Two-way effect: In addition to the one-way effect, there is also a defined shape change upon cooling.
- (c) Pseudo elasticity: Mechanical loading, F , expands the helical spring to a large extent. When the load is removed, the spring still returns to its initial shape.

One-Way Effect

In the martensitic state (Fig.1, $T < M_f$), the material exhibits a very low elastic limit. Elastic straining is followed by a pseudo plastic strain range in which the component can be strained reversibly by up to several percent. Further strain behaviour is characterized by plastic deformation up to fracture. After relaxation in the pseudo-plastic range, an apparent deformation, CIW , is retained. By heating the deformed component above the austenite finish temperature, A_f , a complete shape recovery is possible. The maximum reversible strain, for instance of NiTi single crystals in the direction, is 10.7%. As this effect only occurs upon heating, i.e., only in one direction, it is referred to as a one-way effect. Renewed cooling and heating no longer changes the shape. The original memorized shape is imprinted upon the component prior to loading by heat treatment. If the shape recovery during reverse transformation to austenite is hindered, high forces occur that can be used to perform work. This is the basis of SMA actuators.

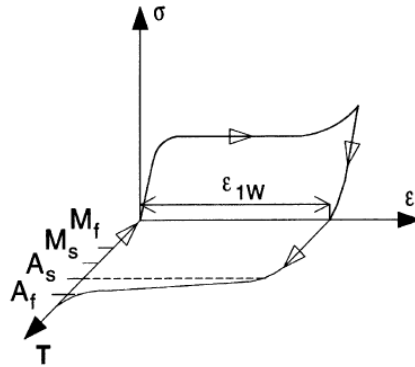

Fig.1 Stress- Strain – temperature characteristic for the one-way effect

Two-Way Effect

The two-way effect is associated with a shape change upon heating and cooling without requiring any external load. This gives rise to a strain characteristic located within the s-T plane, Fig. 2. The shape change can be repeated without renewed deformation. However, in principle, the shape change attained is less pronounced than with the one-way effect. The shape change upon cooling is achieved by imprinting ordered internal stress fields on the material. The underlying mechanism is based on the formation of preferred martensite variants . One special case of the two-way effect is the all-round effect caused by the formation of ThNi4 precipitates with a preferred orientation.

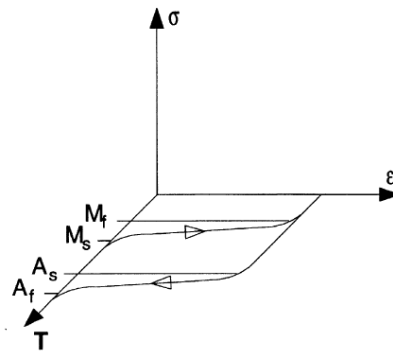

Fig.2 Strain – temperature characteristic for the two-way effect

Pseudo elasticity

In the austenitic state ($T > A_r$), the material exhibits pseudo elastic behaviour, Fig. 3. In contrast to previous effects, no temperature change is required in this case. The strain characteristic is, therefore, located in the σ - ϵ plane. Above the elastic limit, there is a plateau in which a highly nonlinear deformation occurs up to a virtual yield limit, σ_{pe} . Above σ_{pe} , there is plastic deformation up to fracture. If the component is loaded only as far as σ_{pe} , unloading passes through the lower hysteresis loop with the strain disappearing completely. In polycrystalline NiTi, the maximum reversible strain can be 7 to 8% , and in some Cu-

based SMAs, up to 18% . The plateau region is caused by stress-induced transformation of austenite into martensite.

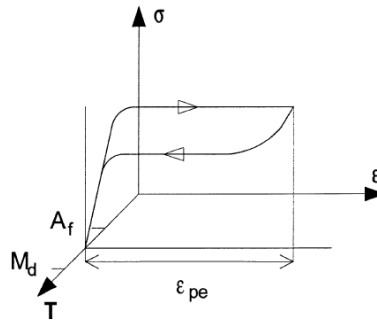

Fig.3 Stress- Strain characteristic for pseudo elasticity

For the stress-induced formation of martensite there is an upper temperature limit, M_d , above which competing irreversible processes, such as the formation of dislocations and slipping, are favoured thermodynamically. The temperature window, $M_d > T > A_r$, in which pseudo elastic behaviour occurs can be set by various thermo mechanical processes [146]. Above M_d , SMAs behave like conventional materials with elastic strain characteristics and subsequent plasticity up to fracture.

Electrostatic Micro actuators

Electrostatic micro shutter

Electrostatic actuators using membranes will be presented first. In metrology and in micro optics, so-called micro shutters have become of great interest. The principle of this shutter is based on the electrostatic deflection of a movable electrode (micro shutter), made of aluminium, gold or doped poly silicon. During an operation, the shutter moves against a fixed silicon electrode (substrate) which was produced by anisotropic wet etching in (110) silicon. This principle of such a shutter is shown.

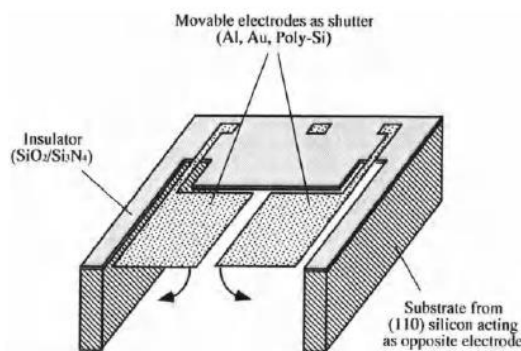

Fig.4. Electrostatic micro shutter

Electrostatic micro pump

The electrostatic membrane principle is well-suited for designing micro pumps. Fig.5 shows a sketch of an electrostatic micro membrane pump. The device consisting of 4 silicon

chips was produced by the bulk micromachining technique. The two upper chips form the drive consisting of the membrane and the electrode; the latter is part of the outer frame. The identical lower chips form the inlet and outlet valves. If a voltage is applied between the membrane and the electrode, the membrane arches toward the electrode thereby generating a partial vacuum in the chamber. This causes the inlet valve to open and liquid to be drawn into the pump chamber. By removing the voltage, the liquid is pushed through the outlet valve. Since the drive unit and the pump chamber are separated, the liquid is not affected by the electric field. This is important when the liquid contains ions, e.g. as in salt solutions or medicines.

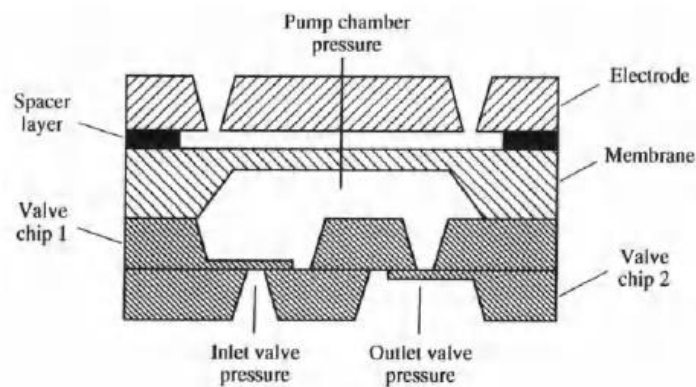

Fig.5. Electrostatic micro pump

Piezoelectric Micro actuators

Micro membrane pump

The micro membrane pump consists of two glass plates and a silicon disc which is sandwiched between the plates, Fig.6.

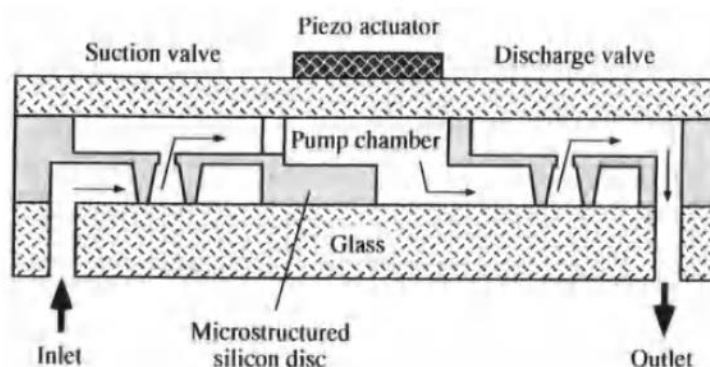

Fig.6. Micro membrane pump

The silicon disc is structured by etching and contains a pump chamber as well as suction and discharge valves. The upper glass plate serves as a pressure-sensitive membrane.

It can change the volume of the pump chamber with the help of a bonded piezo disc (the actuator). When a voltage is applied, the membrane buckles downward and the liquid is forced out through the discharge valve. When the voltage is removed, the membrane returns to its original position and the pump sucks in liquid through the suction valve.

Magnetostrictive Micro actuators

Various solid state actuators have been investigated in the past few years; one example using piezo ceramic was described in the previous section. While piezo actuators have served for a variety of applications, magnetostrictive actuators are still at the threshold of industrial exploration.

The elastic wave motor

A very interesting development is the *Elastic Wave Motor* (EWM), which takes advantage of the properties of Terfenol-D. Here, electric energy is directly transformed into a continuous linear movement. A sketch of the function principle and a schematic design of the motor having a movable Terfenol-D rod and external coils (stator) is shown in Figure. In this device, the rod is placed into a guide tube, the end of which is attached to a rigid support. Several short coils are placed along the outer surface of the tube to produce the magnetic field. If the magnetic field is successively switched on and off from one end of the tube to the other in the coils, the Terfenol-D rod moves within the tube in the opposite direction, as shown in Figure. The speed, force and position of the rod are controlled by the magnetic field. The design is successfully being used in the paper industry. It controls the paper thickness during manufacture and piling by moving a blade across the entire paper width.

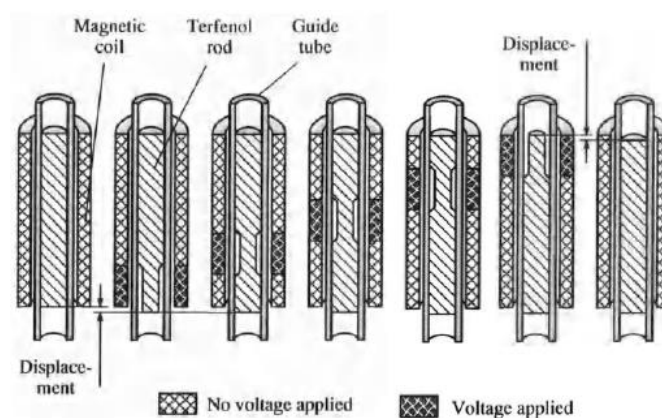

Fig.7. Magnetostrictive Micro actuators

Electromagnetic Micro actuators

Electromagnetically driven micro actuators are gaining in significance as manufacturers are improving the three-dimensional production methods for a variety of materials. With

electromagnetic actuators, electric energy is transformed into mechanical energy like forces or torques.

Linear micromotor

Numerous research projects are concerned with the development of electromagnetic linear actuators. Since almost all present efforts to design linear actuators are based on the silicon technology, the available structures are limited to a height of about 20 μm , which means that the forces that can be produced are very weak. There are few devices using planar coils; a linear motor with a sliding rare earth magnet. The magnet slides in a channel between two silicon chips which are attached to a glass substrate. The operating principle of this motor is depicted in Fig. Planar coils located in the silicon chips are progressively energized to generate the linear motion of the magnet. There are 8 pairs of planar coils, integrated in parallel to the guiding channel of the chip, Fig. The coils opposite one another are driven sequentially with a current of the same magnitude so that a travelling perpendicular magnetic field (parallel to the magnetization of the permanent magnet) is produced. Thus, the magnet is pulled along the channel in a synchronous manner by the moving magnetic field.

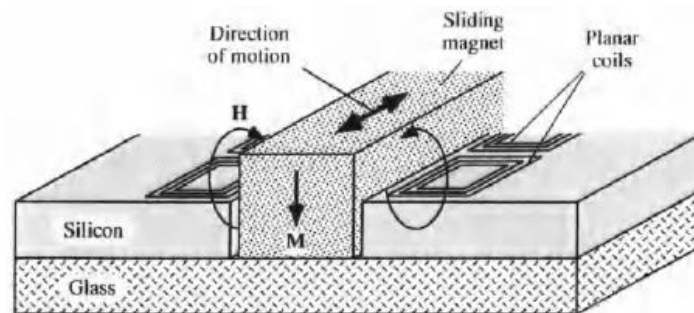

Fig.8.Linear micro motor

SMA-based Micro actuators

When shape memory alloys (SMAs) are deformed under a certain critical temperature and then heated up to above this critical temperature, they will "remember" their original form and assume it again. This effect can be used for generating motions or forces. Characteristic for actuators that use SMA are their low complexity, light weight, small size and large displacement; e.g. SMA components have been used for several years as active pipe connectors. However, the potential use of these alloys in MST has just recently been recognized.

The SMA effect was discovered in various copper alloys, in which a reversible, thermal-mechanical transformation of the atomic structure of the metal takes place at certain temperatures. When the temperature

is raised or lowered, the metallurgical structure of an SMA transforms from a martensitic state (low temperatures) to the austenitic state (high temperatures), or vice versa.

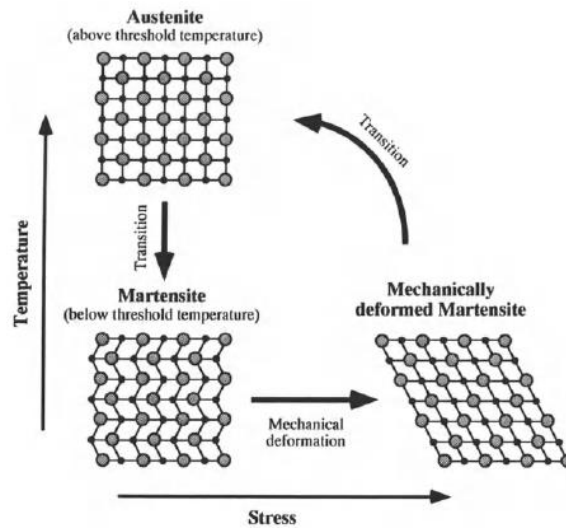

Fig.9. Schematic representation of SMA effect

In Fig.9 the basic transformation mechanism is schematically shown. Starting from a stable and rigid austenitic state, the SMA transforms into the martensitic state as the temperature sinks under the critical temperature; thereby the shape of the SMA can be deformed by up to 8% (as for NiTi-alloys [Menz93]). In the low temperature state, the SMA keeps the desired deformed shape until it is exposed to a higher temperature. When it is warmed up above a threshold temperature, the deformed martensite is transformed back to austenite and the SMA takes on its original form (thermal shape memory). With this property, large displacements can be obtained compared to other actuator principles.

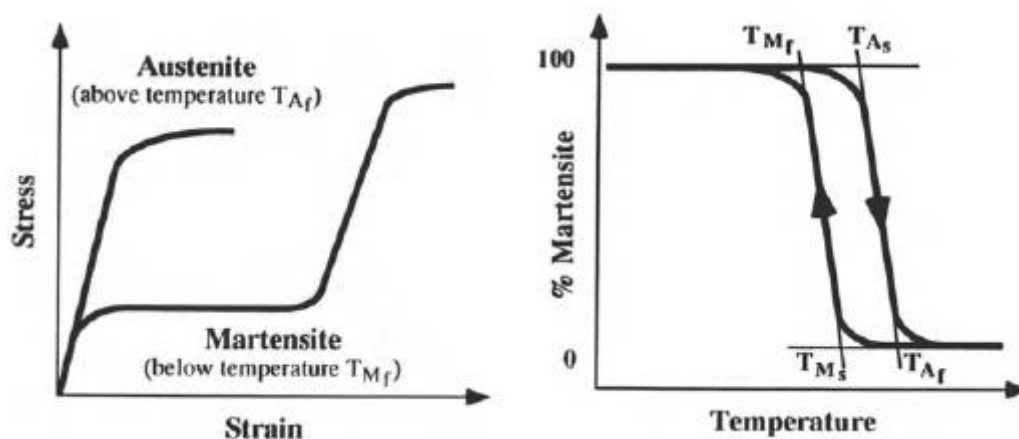

Fig.10. (a)Stress-Strain diagram and (b) the hysteresis curve of an SMA

Micro endoscopes and catheters

Minimal-invasive surgery and new diagnostic techniques require the availability of a new class of micro and miniature instruments, like endoscopes and catheters, which are

equipped with sensors and effectors. The present trend towards minimal invasive therapy requires that precise catheter systems with active guidance will be available to enable the surgeon to enter the various cavities of the human body or to direct them into a specific branch of a blood vessel

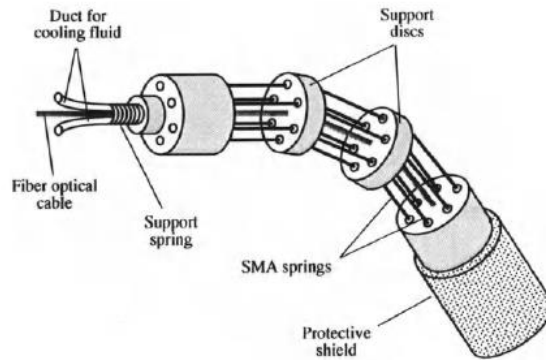

Fig.11. Active endoscope using SMA

There is an electrical connector on each end of the SMA wires to which the electric voltage can be applied. The wires contract when an electric current is applied to them, causing a temperature increase. When the power is turned off, the wires take on their original form after cooling. The direction of motion of the endoscope and its angle of the bend can be controlled by selectively applying electric voltage to each of the three wires.

Hydraulic and Pneumatic Micro actuators

Flexible rubber micro actuators

A flexible micro actuator to be used by miniaturized robots was shown. The actuator is driven by hydraulic or pneumatic pressure, can be bent in every direction and is designed for use as robot hands or legs for various applications. The structure of this device is shown in Fig.12. It is made of rubber reinforced with nylon fibers and has three autonomous actuator chambers. The internal pressure in every chamber can be controlled individually by flexible hoses and valves leading to them. The device can be expanded along its longitudinal axis when the pressure is increased equally in all three chambers. If the pressure is only increased in one chamber, the device bends in the opposite direction.

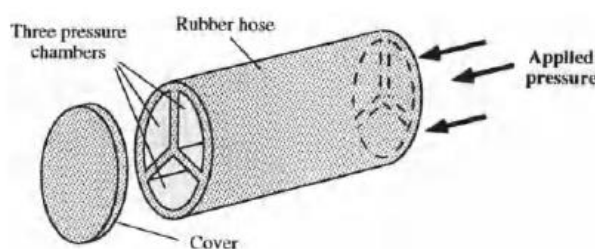

Fig.12. Principle of the pneumatically driven flexible micro actuator

Hydraulic piston micro actuator

An interesting hydraulic micro actuator system was shown.. The piston actuator and its integrated calibration system is depicted in Figure. The actuator chamber with its inlet for its operating fluid, (ex) water, was made by the LIGA process. The unit contains a force-transmitting piston which can be moved along the side walls of the chamber by a fluid. The device is covered by a glass plate (not shown in the figure). A stop groove is added to absorb excessive adhesive which may ooze out when the glass cover plate is being fixed; this is necessary to prevent the piston from sticking to the walls of the chamber.

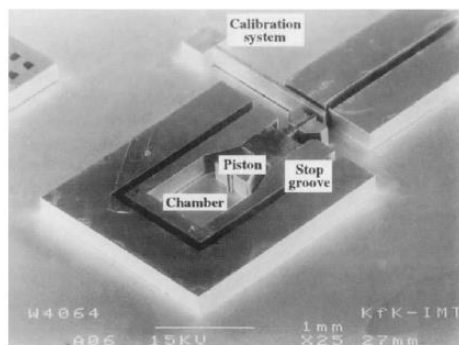

Fig.13. Hydraulic piston micro actuator

Chemical Microactuators

Chemical actuators are based on different chemical processes taking place in fluid or gaseous media. E.g. many chemical reactions produce gases which can be used to create a high pressure in a chamber.

Polymer micro pump

The uni-directional microcapsule polymer pump is shown in Fig.14. It can be used as a medicine dosing system implanted in a patient. The pump cylinder has a semi permeable membrane on its inlet side, which only allows a substance to flow in the direction indicated; a one-way valve is located on the outlet side.

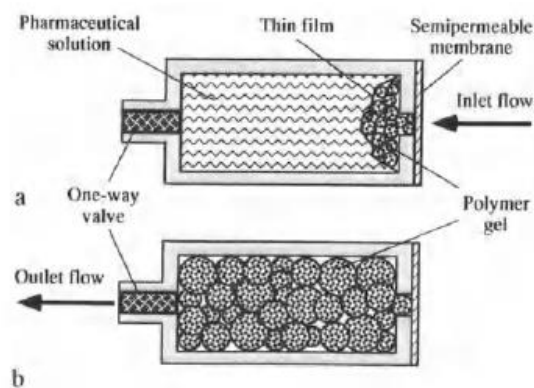

Fig.14. Polymer micro pump (a) Initial state (b) final state

The pump is separated by a thin film and filled with a pharmaceutical solution which is on the left side of the chamber. On the right side of the chamber a highly concentrated water-absorbing polyacrylamide gel is located.

The work cycle of the pump is as follows: the osmotic pressure difference across the membrane takes water from the ambient solution, i.e. from the patient's blood, and drives it through the membrane into the right side of the pump chamber, causing the polymer gel to swell. The pharmaceutical in the microcapsule is pushed out due to the volume increase of the polymer gel. When the pump space is completely occupied by the gel, the medicine is fully injected and the cycle is completed. The duration of the cycle depends on the concentration difference between the polymer gel solution and the ambient solution.

MULTIPLE CHOICE QUESTIONS

1. Pressure is the _____
- a) Force per unit area
 - b) Mass per unit area
 - c) Force per unit volume
 - d) Mass per unit volume

Answer: a

2. Barometer is which type of sensor?
- a) Pressure sensor
 - b) Touch sensor
 - c) Temperature sensor
 - d) Humidity sensor

View Answer

Answer: a

3. Chemiresistor sensors are used for test gases in _____
- a) Solid form
 - b) Liquid form
 - c) Vapour form
 - d) All of the mentioned

Answer: c

4. Which of the following change electrical conductivity on the absorption of a gas molecule?
- a) Tin
 - b) Zinc
 - c) Nickel
 - d) All of the mentioned

Answer: d

5. Training of SMA material done by -----
- a) Joule heating
 - b) Sputtering
 - c) Faraday's law
 - d) None of the mentioned

Answer: a

6. Gauge pressure is also known as:
- a. Manometric pressure
 - b. Barometric pressure
 - c. Absolute pressure
 - d. None of the above

Answer a

7. Atmospheric pressure is also known as:
- a. manometric pressure
 - b. barometric pressure
 - c. absolute pressure
 - d. None of the above

Answer b

8. Pseudoelasticity, sometimes called superelasticity exhibits in
- a. SMA
 - b. Micro biosensor
 - c. fiber

d. None of the above

Answer a

9. Which are the two basic states of shape memory alloys?
- Austenite Phase and Martensitic Phase
 - Austenite Phase and Soft Bake
 - Soft Bake and Martensitic Phase
 - None of the above

Answers: a

10. Which alloy (smart material) was used in lab experiment for Shape Memory Alloy?
- HMDS
 - Nitinol
 - Nichrome
 - Alnico

Answers: b

1. The metals nickel and titanium combined to form SMA is -----
- HMDS
 - Nitinol
 - Nichrome
 - Alnico

Answers: b

Assignment.

- Draw the schematic design of a micro biosensor and explain. Also draw the sensor response curve and explain.
- What is a shape memory alloy? Discuss one way and two way shape memory effect with diagrams

UNIT V SENSOR MATERIALS AND PROCESSING TECHNIQUES

Materials for sensors: Silicon, Plastics, metals, ceramics, glasses, nano materials
Processing techniques: Vacuum deposition, sputtering, chemical vapour deposition, electro plating, photolithography, silicon micro machining: Bulk silicon micromachining, Surface silicon micromachining, LIGA process.

THEORY

Materials for Sensors

Sensor Materials:

Methods of sensor fabrication are numerous and specific for each particular design. They comprise processing of semiconductors, optical components, metals, ceramics, and plastics. Here, we briefly describe some materials and the most often used techniques.

The below mentioned Materials are used to make the sensors:

- Silicon.
- Plastics
- Metals.
- Ceramics.
- Glasses.

Silicon as a Sensing Material:

Silicon is present in the Sun and stars and is a principle component of a class of meteorites known as *aerolites*. Silicon is the second most abundant material on Earth, being exceeded only by oxygen; it makes up to 25.7% of the Earth's crust, by weight. Silicon is not found free in nature, but occurs chiefly as the oxide and as silicates. Some oxides are sand, quartz, rock crystal, amethyst, clay, mica, and so forth. Silicon is prepared by heating silica and carbon in an electric furnace, using carbon electrodes.

There are also several other methods for preparing the element. Crystalline silicon has a metallic luster and grayish color¹. The Czochralski process is commonly used to produce single crystals of silicon used for the solid-state semiconductors and micro machined sensors. Silicon is a relatively inert element, but it is attacked by halogen sand dilute alkali. Most acids, except hydrofluoric, do not affect it. Elemental silicon transmits infrared radiation and is commonly used as windows in far-infrared sensors.

Silicon's atomic weight is 28.0855, and its atomic number is 14. Its melting point is 1410⁰ C and the boiling point is 23⁰C. The specific gravity at 25⁰C is 2.33 and its valence is 4. Properties of silicon are well studied and its applications to sensor designs have been extensively researched worldwide. The material is inexpensive and can now be produced and processed controllably to unparalleled standards of purity and perfection. Silicon exhibits a number of physical effects which are quite useful for sensor applications shown in table.

Silicon should not be confused with silicone, which is made by hydrolyzing silicon organic chloride, such as dimethyl silicon chloride. Silicones are used as insulators, lubricants, and for the production of silicone rubber.

Stimuli of Silicon-Based Sensors

Stimuli	Effects
Radiant	Photovoltaic effect, photoelectric effect, photoconductivity, photo-magneto-electric effect
Mechanical	Piezo resistivity, lateral photoelectric effect, lateral photovoltaic effect
Thermal	Seebeck effect, temperature dependence of conductivity and junction, Nernst effect
Magnetic Chemical	Hall effect, magneto resistance, Suhi effect sensitivity

Unfortunately, silicon does not possess the piezoelectric effect. Most effects of silicon such as the Hall Effect, the Seebeck effect, piezo resistance, and so forth are quite large; however, a major problem with silicon is that its responses to many stimuli show substantial temperature sensitivity. For instance: strain, light, and magnetic field responses are temperature dependent. When silicon does not display the proper effect, it is possible to deposit layers of materials with the desired sensitivity on top of the silicon substrate. For instance, sputtering of ZnO thin films is used to form piezoelectric transducers which are useful for the fabrication of SAW (surface acoustic waves) devices and accelerometers. In the later case, the strain at the support end of the etched micro mechanical cantilever is detected by a ZnO overlay.

Silicon itself exhibits very useful mechanical properties which currently are widely used to fabricate such devices as pressure transducers, temperature sensors, force and tactile detectors by employing the MEMS technologies. Thin film and photolithographic fabrication procedures make it possible to realize a great variety of extremely small, high-precision mechanical structures using the same processes that have been developed for electronic circuits. High-volume batch-fabrication techniques can be utilized in the manufacture of complex miniaturized mechanical components which may not be possible with other methods

Although single-crystal silicon (SCS) is a brittle material, yielding catastrophically (not unlike most oxide-based glasses) rather than deforming plastically (like most metals), it certainly is not as fragile as is often believed. Young's modulus of silicon (1.9×10^{12} dyn/cm or 27×10^6 psi), for example, has a value of that approaching stainless steel and is well above that of quartz and of most glasses. The misconception that silicon is extremely fragile is based on the fact that it is often obtained in thin slices (5–13-cm-diameter wafers) which are only 250–500 μm thick. Even stainless steel at these dimensions is very easy to deform in elastically.

As mentioned earlier, many of the structural and mechanical disadvantages of SCS can be alleviated by the deposition of thin films. Sputtered quartz, for example, is utilized routinely by industry to passivate integrated circuit chips against airborne impurities and mild atmospheric corrosion effects. Another example is a deposition of silicon nitrate which has hardness second only to diamond. Anisotropic etching is a key technology for the micromachining of miniature three-dimensional structures in silicon. Two etching systems are of practical interest. One is based on ethylenediamine and water with some additives. The other consists of purely inorganic alkaline solutions like KOH, NaOH, or LiOH.

Forming the so-called *polysilicon* (PS) materials allows one to develop sensors with unique characteristics. Polysilicon layers (on the order of 0.5 μm) may be formed by vacuum deposition onto oxide silicon wafer with an oxide thickness of about 0.1 μm . Polysilicon structures are doped with boron by a technique known in the semiconductor industry as LPCVD (low-pressure chemical vapor deposition).

Fig.1A shows the resistivity of boron-doped LPCVD polysilicon in a comparison with SCS. The resistivity of PS layers is always higher than that of a single crystal material, even when the boron concentration is very high. At low doping concentrations, the resistivity climbs rapidly, so that only the impurity concentration range is of interest to a sensor fabrication. The resistance change of PS with temperature is not linear. The temperature coefficient of resistance may be selected over a wide range, both positive and negative, through selected doping (Fig.1B). Generally, the temperature coefficient of resistance increases with decreased doping concentration. The resistance at any given temperature of a PS layer may be found from

$$R(T) = R_{20} \alpha_R (T - T_0), \quad (18.1)$$

Where,

$$\alpha_R = \frac{1}{R_{20}} \frac{dR(T_0)}{dT}$$

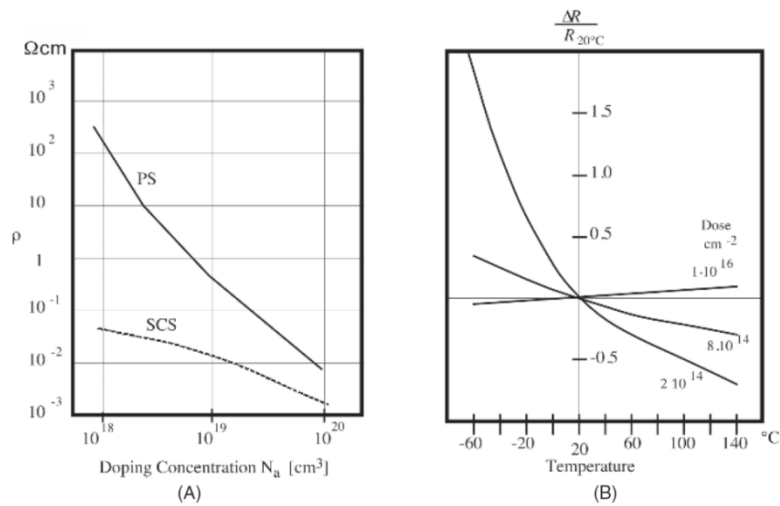

Fig.1. (A) Specific resistivity of boron-doped silicon, (B) temperature coefficient of resistivity of silicon for different doping concentrations.

Plastics

Plastics are synthetic materials made from chemical raw materials called monomers. A monomer (one chemical unit) such as ethylene is reacted with other monomer molecules to form long chains of repeating ethylene units, forming the polymer polyethylene. In a similar manner, polystyrene is formed from styrene monomers. The polymers consist of carbon atoms in combination with other elements. Polymer chemists use only eight elements to create thousands of different plastics. These elements are carbon (C), hydrogen (H), nitrogen (N), oxygen (O), fluorine (F), silicon (Si), sulfur (S), and chlorine (Cl). Combining these elements in various ways produces extremely large and complex molecules.

Element	Atomic weight	Energy Bonds	
Hydrogen	1	-H	1
Carbon	12	-C-	4
Nitrogen	14	-N-	3
Oxygen	16	-O-	2
Fluorine	19	-F	1
Silicon	28	-Si-	4
Sulfur	32	-S-	2
Chlorine	35	-Cl	1

Fig. 2 The atomic building blocks for polymers.

Each atom has a limited capacity (energy bonds) for joining with other atoms, and every atom within a molecule must have all of its energy bonds satisfied if the compound is

to be stable. For example, hydrogen can bond only to one other atom, whereas carbon or silicon must attach to four other atoms to satisfy its energy bonds. Thus, H-H and H-F are stable molecules, whereas C-H and Si-Cl are not. Fig.2 shows all eight atoms and the corresponding energy bonds.

Adding more carbon atoms in a chain and more hydrogen atoms to each carbon atom creates heavier molecules. For example, ethane gas (C₂H₆) is heavier than methane gas because it contains additional carbon and two hydrogen atoms. Its molecular weight is 30. Then, the molecular weight can be increased in increments of 14 (1 carbon + 2 hydrogen), until the compound pentane (C₅H₁₂) is reached. It is too heavy to be gas and, indeed, it is liquid at room temperature. Further additions of CH₂ groups make progressively a heavier liquid until C₁₈H₃₈ is reached. It is solid: paraffin wax.

If we continue and grow larger molecules, the wax becomes harder and harder. At about C₁₀₀H₂₀₂, the material with a molecular weight of 1402 is tough enough and is called a low-molecular-weight *polyethylene*, the simplest of all thermoplastics. Continuing the addition of more CH₂ groups further increases the toughness of the material until medium-molecular-weight (between 1000 and 5000 carbons) and high-molecular-weight polyethylene. Polyethylene, being the simplest polymer (Fig.3), has many useful properties in sensor technologies. For example, polyethylene is reasonably transparent in the mid- and far-infrared spectral ranges and thus is used for fabrication of infrared windows and lenses.

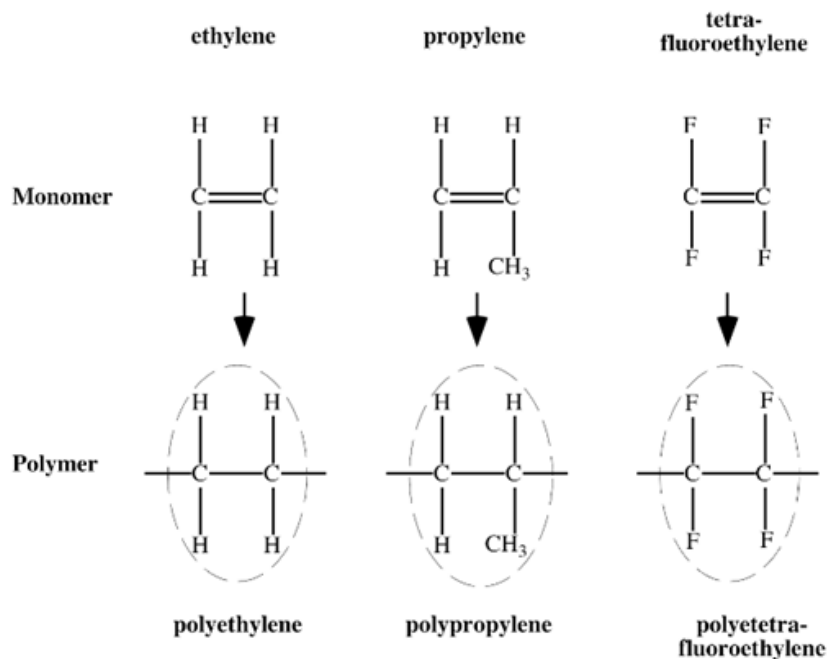

Fig. 3. Monomers and their respective polymer units.

By applying heat, pressure, and catalysts, monomers are grown into long chains. The process is called polymerization. Chain length (molecular weight) is important because it determines many properties of a plastic. The major effect of increased length is increased toughness, creep resistance, stress-crack resistance, melt temperature, melt viscosity, and difficulty of processing. After polymerization is completed, the finished polymer chains resemble long intertwined bundles of spaghetti with no physical connections between chains. Such a polymer is called *thermoplastic* (heat-moldable) polymer.

If chains are packed closer to one another, a denser polyethylene is formed which, in effect, results in the formation of crystals. Crystallized areas are stiffer and stronger. Such polymers are more difficult to process because they have higher and sharper melt temperatures; that is, instead of softening, they quickly transform into low viscosity liquids. On the other hand, amorphous thermoplastics soften gradually, but they do not flow as easily as crystalline plastics. The examples of amorphous polymers are acrylonitrile–butadiene–styrene, polystyrene, polycarbonate, polysulfone, and polyetherimide. Crystalline plastics include polyethylene, polypropylene, nylon, polyvinylidene fluoride (PVDF), acetal, and others.

The following is a non-exhaustive list of thermoplastics:

ABS (acrylonitrile–butadiene–styrene) is very tough, yet hard and rigid. It has fair chemical resistance, low water absorption, and good dimensional stability. Some grades may be electroplated.

Acrylic has high optical clarity and excellent resistance to outdoor weathering. This is a hard, glossy material with good electrical properties. It is available in a variety of colors.

Fluoroplastics comprise a large family of materials (PTFE, FEP, PFA, CTFE, ECTFE, ETFE, and PVDF) with excellent electrical properties and chemical resistance, low friction, and outstanding stability at high temperatures. However, their strength is moderate and the cost is high.

Nylon (polyimide) has outstanding toughness and wears resistance with a low coefficient of friction. It has good electrical and chemical properties. However, it is hygroscopic and dimensional stability is worst than in most other plastics.

Polycarbonate has the highest impact resistance. It is transparent with excellent outdoor stability and resistance to creep under load. It may have some problems with chemicals.

Polyester has excellent dimensional stability but is not suitable for outdoor use or for service in hot water.

Polyethylene is lightweight and inexpensive with excellent chemical stability and good electrical properties. It has moderate transparency in the broad spectral range from visible to far infrared; it has poor dimensional and thermal stability.

Polypropylene has outstanding resistance to flex and stress cracking with excellent chemical and electrical properties with good thermal stability. It is lightweight and inexpensive. Optical transparency is good down to the far-infrared spectral range. However, absorption and scattering of photons in the mid-infrared range is higher than in polyethylene.

Polyurethane is tough, extremely abrasion, and impact resistant. It can be made into films and foams. It has good chemical and electrical properties; however, UV exposure degrades its quality.

Another type of plastic is called *thermoset*, in which polymerization (curing) is done in two stages: one by the material manufacturer and the other by the molder. An example is phenolic, which during the molding process is liquefied under pressure, producing a cross-linking reaction between molecular chains. After it has been molded, a thermoset plastic has virtually all of its molecules interconnected with strong physical bonds, which are not heat reversible. In effect, curing, a thermoset is like cooking an egg. Once it is cooked, it will remain hard. In general, thermoset plastics resist higher temperatures and provide greater dimensional stability. This is the reason why such thermoset plastics such as polyester (reinforced) is used to make boat hulls and circuit-breaker components, epoxy is used to make printed circuit boards, and melamine is used to make dinnerware. On the other hand, thermoplastics offer higher impact strength, easier processing, and better adaptability to complex designs than do thermosets.

The thermoplastics that are most useful in sensor-related applications are the following.

Alkyd has excellent electrical properties and very low moisture absorption.

Allyl(diallyl phtalate) has outstanding dimensional stability and high heat and chemical resistance.

Epoxy has exceptional mechanical strength, electrical properties, and adhesion to most of materials.

Phenolic is a low-cost material. The color is limited to black and brown.

Polyester (thermoplastic version) has a great variety of colors and may be transparent or opaque. Shrinkage is high.

If two different monomers (A and B) are combined in a polymerization reaction, such a polymer is called *copolymer*. The final properties of a copolymer depend on the ratio of components A and B. Polymer mechanical properties can be modified by providing additives, such as fibers to increase strength and stiffness, plasticisers for flexibility, lubricants for easier molding, or UV stabilizers for better performance in sunlight.

Another good way to control properties of plastics is to make polymer alloys or blends. Primarily this is done to retain properties of each component.

Conductive plastic: Being wonderful electrical isolators, plastic materials often require lamination with metal foil, painting with conductive paint, or metallization to give them electrical conductive properties, required for shielding. Another way of providing electrical conductivity is mixing plastics with conductive additives (e.g., graphite or metal fibers) or building composite plastic parts incorporating metal mesh.

Piezoelectric plastics: These are made from PVF₂, PVDF, and copolymers which are crystalline materials. Initially, they do not possess piezoelectric properties and must be poled either in high voltage or by corona discharge. Metal electrodes are deposited on both sides of the film either by silk-screening or vacuum metallization. These films, in some applications are used instead of ceramics, because of their flexibility and stability against mechanical stress. Another advantage of the piezoelectric plastics is their ability to be formed into any desirable shape.

METALS

From the sensor designer stand point, there are two classes of metal: nonferrous and ferrous. Ferrous metals, like steel, are often used in combination with magnetic sensors to measure motion, distance, magnetic field strength, and so forth. Also, they are quite useful as magnetic shields. Nonferrous metals, on the other hand, are permeable to magnetic fields and used whenever these fields are of no concern.

Nonferrous metals offer a wide variety of mechanical and electrical properties. When selecting a metal, one must consider not only its physical properties but also ease of mechanical processing. For example, copper has excellent thermal and electrical properties, yet it is difficult to machine; therefore, in many instances, aluminum should be considered as a compromise alternative. *Aluminum* has a high strength-to weigh ratio and possesses its own anticorrosion mechanism. When exposed to air, aluminum does not oxide progressively, like iron would do. The protection is provided by a microscopic oxide coating which forms on the surface and seals the bare metal from the environment.

There are hundreds of aluminum alloys. They can be processed in many ways, such as drawing, casting, and stamping. Some alloys can be soldered and welded. In addition to excellent electrical properties, aluminum is a superb reflector of light over nearly the entire spectrum from UV to radio waves. Aluminum coatings are widely used for mirrors and waveguides. In the mid- and far-infrared range, the only superior to aluminum reflector is gold.

Beryllium has several remarkable properties. Its low density (two-thirds that of aluminum) is combined with a high modulus per weight (five times that of steel), high specific heat, excellent dimensional stability, and transparency to X-rays. However, this is an expensive metal. Like aluminum, beryllium forms a protective coating on its surface, thus resisting corrosion. It may be processed by many conventional methods, including powder cold pressing. The metal is used as X-ray windows, optical platforms, mirror substrates, and satellite structures.

Magnesium is a very light metal with a high strength-to-weight ratio. Due to its low modulus of elasticity, it can absorb energy elastically, which gives it good damping characteristics. The material is very easy to process by most of metal-working techniques.

Nickel allows the design of very tough structures which are also resistant to corrosion. When compared with steel, the nickel alloys have ultrahigh strength and a high modulus of elasticity. Its alloys include binary systems with copper, silicon, and molybdenum. Nickel and its alloys preserve their mechanical properties down to cryogenic temperatures and at high temperatures up to 1200°C. Nickel is used in high-performance superalloys such as Inconel, Monel (Ni–Cu), Ni–Cr, and Ni–Cr–Fe alloys.

Copper combines very good thermal and electrical conductivity properties (second only to pure silver) with corrosion resistance and relative ease of processing. However, its strength-to-weight ratio is relatively poor. Copper is also difficult to machine. Copper and its alloys—the brasses and bronzes—come in variety of forms, including films. Brasses are alloys which contain zinc and other designated elements. Bronzes comprise several main groups: copper–tin–phosphorus (phosphor bronze), copper–tin–lead–phosphorus (lead phosphor bronzes), and copper–silicon (silicon bronzes) alloys. Under outdoor condition, copper develops a blue-green patina. This can be prevented by applying an acrylic coating. A copper alloy with beryllium has excellent mechanical properties and used to make springs.

Lead is the most impervious of all common metals to X-rays and γ - radiation. It resists attack by many corrosive chemicals, most types of soil, and marine and industrial environments. It has a low melting temperature, ease of casting and forming, and good sound

and vibration absorption. It possesses natural lubricity and wear resistance. Lead is rarely used in pure form. Its most common alloys are “hard lead” (1–13% of antimony), calcium, and tin alloys which have better strength and hardness.

Platinum is a silver-white precious metal which is extremely malleable, ductile, and corrosion resistant. Its positive temperature coefficient of resistance is very stable and reproducible, which allows its use in temperature sensing.

Gold is extremely soft and chemically inert metal. It can only be attacked by *aquaregia* and by sodium and potassium in the presence of oxygen. One gram of pure gold can be worked into a leaf covering 5000 cm² and only less than 0.1 μm thick. Mainly, it is used for plating and is alloyed with other metals like copper, nickel, and silver. In sensor applications, gold is used for fabricating electrical contacts and plating mirrors and waveguides operating in the mid- and far-infrared spectral ranges.

Silver is the least costly of all precious metals. It is very malleable and corrosion resistant. It has the highest electrical and thermal conductivity of all metals.

Palladium, iridium, and rhodium resemble and behave like platinum. They are used as electrical coatings to produce hybrid and printed circuit boards and various ceramic substrates with electrical conductors. Another application is in the fabrication of high-quality reflectors operating in a broad spectral range, especially at elevated temperatures or highly corrosive environments. Iridium has the best corrosion resistance of all metals and thus used in the most critical applications.

Molybdenum maintains its strength and rigidity up to 1600°C. The metal and its alloys are readily machinable by conventional tools. In non oxidizing environments, it resists attacks by most acids. Its prime application is for high-temperature devices, such as heating elements and reflectors of intense infrared radiation for high temperature furnaces. Molybdenum has a low coefficient of thermal expansion and resists erosion by molten metals.

Tungsten in many respects is similar to molybdenum, but can operate even at higher temperatures. A thermocouple sensor fabricated of tungsten is alloyed with 25% rhenium with another wire, in a thermocouple with 5% rhenium.

Zinc is seldom used alone, except for coating; it is mainly used as an additive in many alloys.

Ceramics:

In sensor technologies, ceramics are very useful crystalline materials because of their structural strength, thermal stability, light weight, resistance to many chemicals, ability to bond with other materials, and excellent electrical properties. Although most metals form at least one chemical compound with oxygen, only a handful of oxides are useful as the principal constituent of ceramics. Examples are alumina and beryllia. The natural alloying element in alumina is silica; however, alumina can be alloyed with chromium, magnesium, calcium, and other elements.

Several metal carbides and nitrides qualify as ceramics. The most commonly used are boron carbide and nitride and aluminium nitride. Whenever fast heat transfer is of importance, aluminium nitride should be considered, whereas silicon carbide has high dielectric constant, which makes it attractive for designing capacitive sensors. Due to their hardness, most ceramics require special processing. A precise and cost-effective method of cutting various shapes of ceramic substrates is scribing, machining, and drilling by use of computer-controlled CO₂ laser. Ceramics for the sensor substrates are available from many manufacturers in thicknesses ranging from 0.1 to 10 mm.

Glasses:

Glass is an amorphous solid material made by fusing silica with a basic oxide. Although its atoms never arrange themselves into crystalline structure, the atomic spacing in glass is quite tight. Glass is characterized by transparency, availability in many colors, hardness, and resistance to most chemicals except hydrofluoric acid. Most glasses are based on the silicate system and is made from three major components: silica (SiO₂), lime (CaCO₃), and sodium carbonate (Na₂CO₃). Nonsilicate glasses include phosphate glass (which resists hydrofluoric acid), heat-absorbing glasses (made with FeO), and systems based on oxides of aluminum, vanadium, germanium, and other metals. An example of such specialty glass is arsenictrisulfate (As₂S₃) known as AMTIR, which is substantially transparent in mid- and far-infrared spectral ranges and is used for fabricating infrared optical devices.

Borosilicate glass is the oldest type of glass which is substantially resistant to thermal shock. Under the trademark Pyrex®, some of the SiO₂ molecules are replaced by boric oxide. The glass has a low coefficient of thermal expansion and thus is used for the fabrication optical mirrors (such as in telescopes).

Lead-alkali glass (lead glass) contains lead monoxide (PbO) which increases its index of refraction. Also, it is a better electrical insulator. In the sensor technologies, it is used for fabricating optical windows and prisms and as a shield against nuclear radiation.

Other glasses include aluminosilicate glass (in which Al_2O_3 replaces some silica), 96% silica, and fused silica.

Another class of glass is *light-sensitive* glasses which are available in three grades. Photo chromatic glass darkens when exposed to UV radiation and clears when the UV radiation is removed or glass is heated. Some photo chromatic compositions remain darkened for a week or longer. Others fade within few minutes when UV radiation is removed. The photosensitive glass reacts to UV radiation in a different manner. If it is heated after exposure, it changes from clear to opal. This allows the creation of some patterns within the glass structure. Moreover, the exposed opalized glass is much more soluble in hydrofluoric acid, which allows for an efficient etching technique.

LIST OF NANO MATERIALS PROCESSING TECHNIQUES

- ❖ Vacuum deposition.
- ❖ Sputtering.
- ❖ Chemical vapour deposition.
- ❖ Electroplating.
- ❖ Photolithography.

Vacuum deposition

A metal can be converted into gaseous form and then deposited on the surface of the sample. The evaporation system consists of a vacuum chamber (Fig.4) where a diffuse pump evacuates air down to 10^{-6} – 10^{-7} torr of pressure. A deposited material is placed into a ceramic crucible which is heated by a tungsten filament above the metal melting point. An alternative method of heating is the use of an electron beam.

On a command from the control device, the shutter opens and allows the metal atoms emanated from the molten metal to deposit on the sample. Parts of the sample which remain free of the film are protected by the mask. The film thickness is determined by the evaporation time and the vapor pressure of the metal. Hence, materials with a low melting point are easy to deposit (e.g., aluminum). In general, vacuum deposited films have large residual stress and thus this technique is used mainly for depositing only thin layers.

Because the molten material is virtually a point source of atoms, it may cause both non uniform distribution of the deposited film and the so-called shadowing effect where the edges of the masked pattern appear blurry. Two methods may help to alleviate this problem.

One is the use of multiple sources where more than one crucible (often three or four) is used. Another method is the rotation of the target.

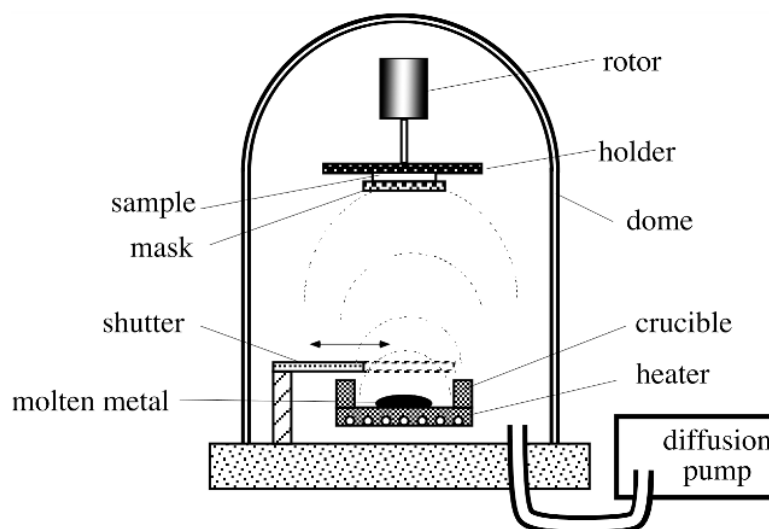

Fig.4. Deposition of a thin metal film in a vacuum chamber.

When using vacuum deposition, one must pay attention to the introduction of spurious materials into the chamber. For instance, even a minuscule amount of oil leaking from the diffuse pump will result in the burning of organic materials and code position on the sample of such undesirable compounds as carbohydrates.

Sputtering

As in the vacuum-deposition method, sputtering is performed in a vacuum chamber (Fig.5); however, after evacuation of air, an inert gas, such as argon or helium, is introduced into the chamber at about 2×10^{-6} to 5×10^{-6} torr. An external high voltage dc or ac power supply is attached to the cathode (target), which is fabricated of the material which has to be deposited on the sample. The sample is attached to the anode at some distance from the cathode. A high voltage ignites the plasma of the inert gas, and the gas ions bombard the target. The kinetic energy of the bombarding ions is sufficiently high to free some atoms from the target surface. Hence, the escaped sputtered atoms deposit on the surface of the sample.

The sputtered techniques yields better uniformity, especially if a magnetic field is introduced into the chamber, allowing for better directing of the atoms toward the anode. Because this method does not require a high temperature of the target, virtually any material, including organic, can be sputtered. Moreover, materials from more than one target can be deposited at the same time (co sputtering), permitting a controlled ratio of materials.

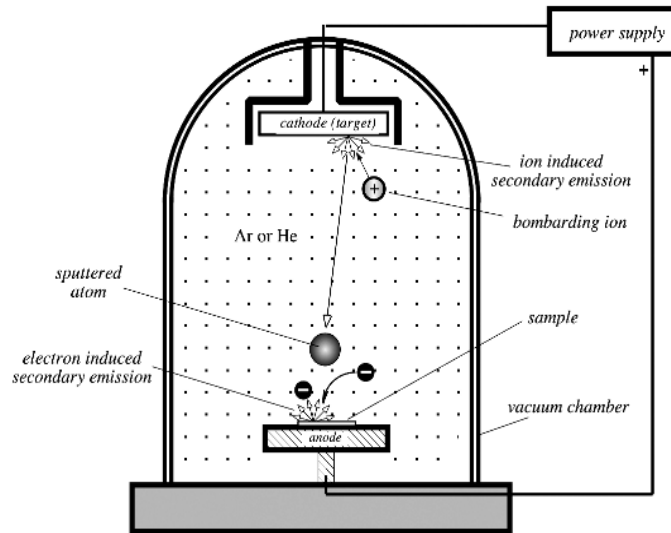

Fig. 5. Sputtering process in a vacuum chamber.

For example, this can be useful for sputtering nichrome (Ni and Cr) electrodes on the surface of the pyroelectric sensors.

Chemical Vapour deposition:

A chemical vapor phase deposition (CVD) process is an important technique for the production of optical, optoelectronic, and electronic devices. For sensor technologies, it is useful for forming optical windows and the fabrication of semiconductor sensors where thin and thick crystalline layers have to be deposited on the surface.

The CVD process takes place in a deposition (reaction) chamber, one of the versions of which is shown in a simplified form in Fig.6. The substrates or wafers are positioned on a stationary or rotating table (the substrate holder) whose temperature is elevated up to the required level by the heating elements. The top cover of the chamber has an inlet for the carrier H₂ gas, which can be added by various precursors and dopants.

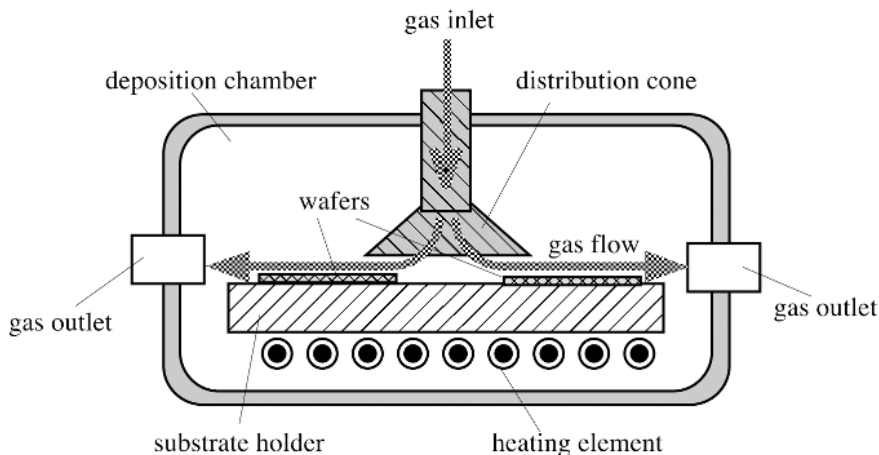

Fig.6. Simplified structure of a CVD reactor chamber.

These additives, while being carried over the heated surface of the substrate, form a film layer. The gas mixture flows from the distribution cone over the top surface of the wafers and exits through the exhaust gas outlets. The average gas pressure in the chamber may be near 1 atm, or somewhat lower. For example, a 6000-Å layer of $Ga_{0.47}In_{0.53}As$ can be grown on the InP substrate at 1 atm and 630°C with a rate of 1.4 Å/s.

Electroplating

Electroplating is the process of applying a metal coating on another piece of metal (or another conductive surface) through an electro-deposition process. In electroplating, the deposited metal becomes part of the existing product with the plating/coating.

The Electroplating process is quite similar to the Electroforming process: both are a form of additive manufacturing, and both work through an electro-deposition process. In Electroplating, both an anode and a cathode (the metal part to be coated) are immersed in an electrolytic bath that is composed of a solution of salts, including the metal to be plated. A direct current (DC) of electricity is passed through the solution, affecting the transfer of metal ions onto the cathodic surface, plating the metal onto the item.

Electroplating comes with several material capabilities. The materials used in the plating (coating) process depend on the composition of the plating bath and the deposition conditions.

Here are the most commonly used materials:

- ❖ Nickel
- ❖ Black nickel/chromium
- ❖ Chromium
- ❖ Palladium or Palladium Nickel Alloy
- ❖ Gold
- ❖ Silver
- ❖ Copper
- ❖ Tin
- ❖ Platinum
- ❖ Ruthenium
- ❖ Cadmium
- ❖ Brass
- ❖ Zinc

The applications of electroplating:

A good example to demonstrate the purpose of electroplating is an application in the medical devices industry. A lot of components for medical devices are created with nickel. Nickel, however, isn't supposed to come into direct contact with the human body. So

to prevent that contact from occurring, a coating of palladium or gold is applied to the nickel surface.

The same coating process applies to an ink-jetting nozzle plate, where the released chemicals would cause the nickel plates to deteriorate. If you require a component that's highly resistant to corrosive environments, electroplating can help create that property.

To sum up, it can be realised the next-level engineering by leveraging the synergy between electroplating and electroforming, rather than seeing them as independent manufacturing methods. Electroforming has the advantages such as ultra-precision metal parts, high repeatability, and short lead and delivery times

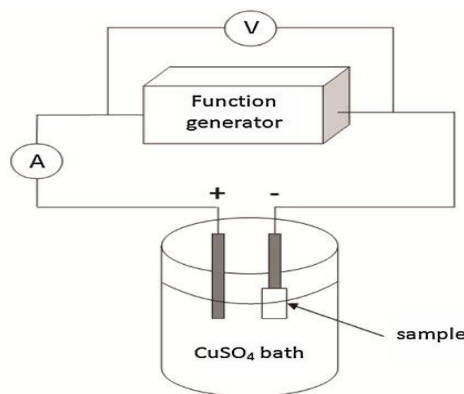

Fig.7. Example of copper Electro plating

Photolithography

Photolithography is the basic technique used to define the shape of micro machined structures in the three techniques outlined below. The technique is essentially the same as that used in the microelectronics industry.

Fig. 8A shows a thin film of some material (e.g., silicon dioxide) on a substrate of some other material (e.g., a silicon wafer). The goal of the process is to selectively remove some silicon dioxide (oxide) so that it only remains in particular areas on the silicon wafer (Fig. 8F).

The process begins with producing a mask. This will typically be a chromium pattern on a glass plate. The wafer is then coated with a polymer which is sensitive to UV light (Fig. 8B), called a photo resist. Ultraviolet light is then shone through the mask onto the photo resist (Fig.8C). The photo resist is then developed which transfers the pattern on the mask to the photo resist layer (Fig.8D).

There are two types of photo resist, termed positive (left side of Fig.8) and negative (right side of Fig.8).

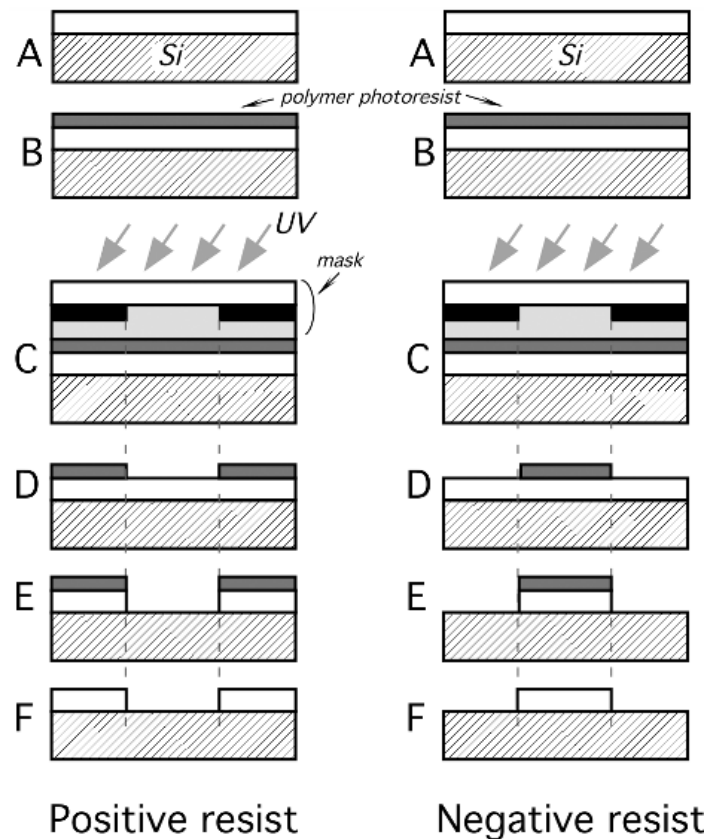

Fig.8. Photolithography

Where the ultraviolet light strikes the positive resist, it weakens the polymer, so that when the image is developed, the resist is washed away where the light struck it—transferring a positive image of the mask to the resist layer. The opposite occurs with negative resist. Where the ultraviolet light strikes negative resist it strengthens the polymer, so when developed, the resist that was not exposed to UV light is washed away—a negative image of the mask is transferred to the resist. A chemical (or some other method) is then used to remove the oxide where it is exposed through the openings in the resist (Fig. 8E). Finally, the resist is removed, leaving the patterned oxide (Fig.8F).

Silicon Micromachining.

Types of the Silicon Micromachining

- ❖ Bulk Silicon Micromachining.
- ❖ Surface Silicon Micromachining.
- ❖ LIGA process.

Bulk Silicon Micromachining:

The bulk micromachining technique was developed in the 60's and allows the structuring of silicon in three dimensions. A high aspect ratio can be reached for micromechanical components which can be formed directly from the silicon wafer. The

crystal orientation of the wafer plays a decisive role. The silicon wafer is pre-processed with optical lithography and the exposed resist material is removed. By using anisotropic etching solutions selectively on the resist, deep grooves can be made on a substrate. The remaining resist acts as a mask. The resulting form depends only on the crystal orientation of the substrate, i.e. along which crystal face the wafer was cut. Different constructions, such as bridges, beams, membranes etc., can be made by this technique, Fig. 9.

Many wafers produced this way can be connected by using bonding or other interconnection technologies to form complex three-dimensional structures. The possibilities are still limited, however, since the lattice structure of the silicon crystal is not variable. Simple circular, cylindrical cavities or columns cannot be realized with this method.

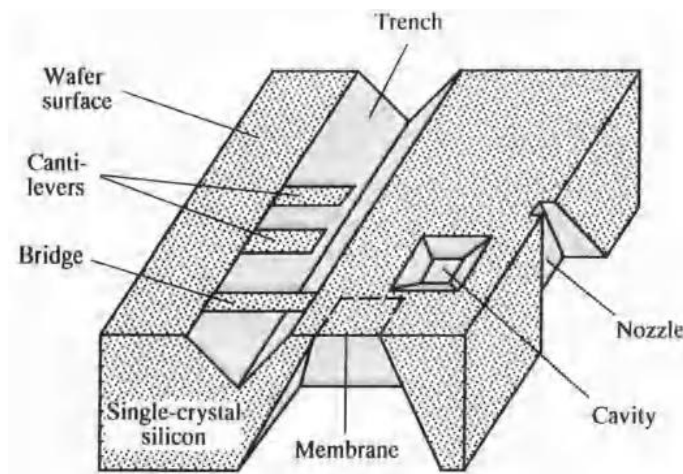

Fig.9. Various bulk micromachining structures.

In order to be able to structure the substrate exactly, additional techniques are necessary to interrupt the etching process at the right time. Otherwise the substrate will simply be etched through. Etch-stop techniques are applied here to form very thin membranes or grooves with flat bottoms, which are otherwise difficult to make. A detailed description of the etch-stop techniques can be found in. Two basic methods will be described below.

Boron implantation (p+ etch-stop):

The p+ etch-stop technique has many applications. It is based on doping the silicon substrate with germanium, phosphorus or boron atoms. This way, the etch rate of various selective etch solutions can be drastically reduced. Boron has the strongest effect and is therefore almost always used. In order to form a thin membrane, the silicon substrate is doped with boron atoms on one side, using a boron concentration of about 10^{20} cm^{-3} or higher. Then the substrate is etched on the other side. As soon as the solution meets the boron-doped layer, the etching process is drastically slowed down. Thereby, a 2-3 f.t.m thick membrane

can be obtained depending on the doping depth. Fig.10 shows the manufacturing steps of a silicon membrane as a sandwich structure using the bulk micromachining technique in connection with doping.

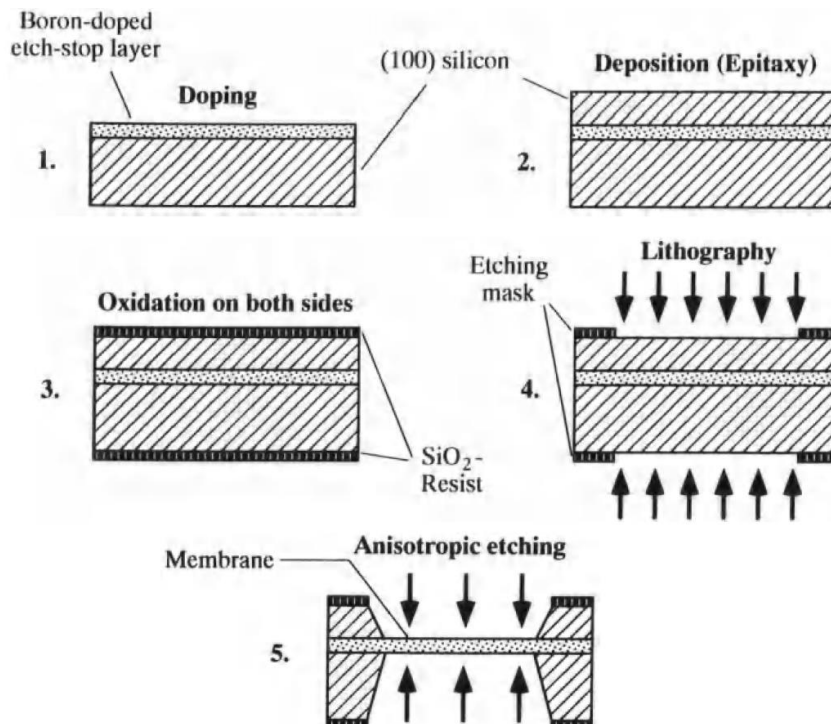

Fig.10. The production of a membrane by the p+ etch-stop technique

First, the substrate surface is saturated with boron atoms until the desired concentration is reached. This forms an etch-stop layer (1). A second silicon layer is put on the etch-stop layer by using epitaxy (2) and then both sides of the work piece are oxidized (3). The silicon dioxide layer can then be structured photo lithographically (4), and after isotropic etching on both sides, the boron-doped layer remains as a membrane (5). Thin membranes make it difficult to get a uniform membrane thickness by doping with the diffusion method, because the membrane thickness depends on various parameters, such as the ion concentration, the wafer thickness etc. Ion implantation can be used instead, although the process duration is very long. For a boron implantation of 2 f.tm with a concentration of 10^{20}cm^{-3} , a 150 f.tA implanter needs up to an hour per wafer.

Electrochemical etch-stop technique

An alternative is the so-called electrochemical etch-stop technique. Here, for certain etch solutions the etching process is interrupted when an electric voltage is applied to an np or pn silicon substrate. For example, a protective n doped silicon layer is deposited onto a p-substrate. When the interruption voltage is applied, the etching process stops at the pn-transition, Fig. 11.

The thickness of the n-layer, which remains as the desired membrane, can be determined during the deposition process.

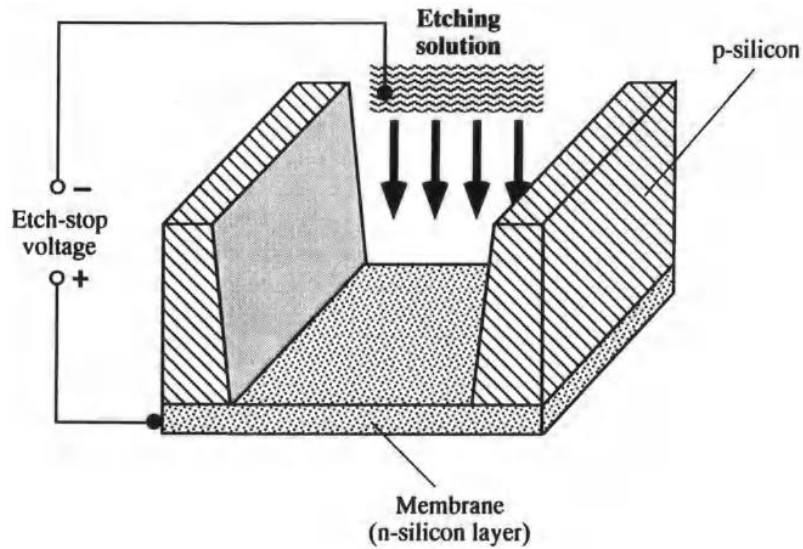

Fig.11. Membrane produced by the electrochemical etch-stop method

Wet and Dry Etch in Bulk Micromachining:

Wet and dry etch techniques have been developed to provide the various shapes needed for MEMS devices. Grooves and slots are used in assembly, such as putting multiple wafers together with different devices on each wafer. V-shaped grooves are also used to finely align fiber optics to micro optical components. Nozzles are used for devices such as inkjet print heads, cavities for open volumes or chambers in pumps or voids under membranes, and channels to pass fluids through. These shapes are formed by using different processes that create either an isotropic or anisotropic profile.

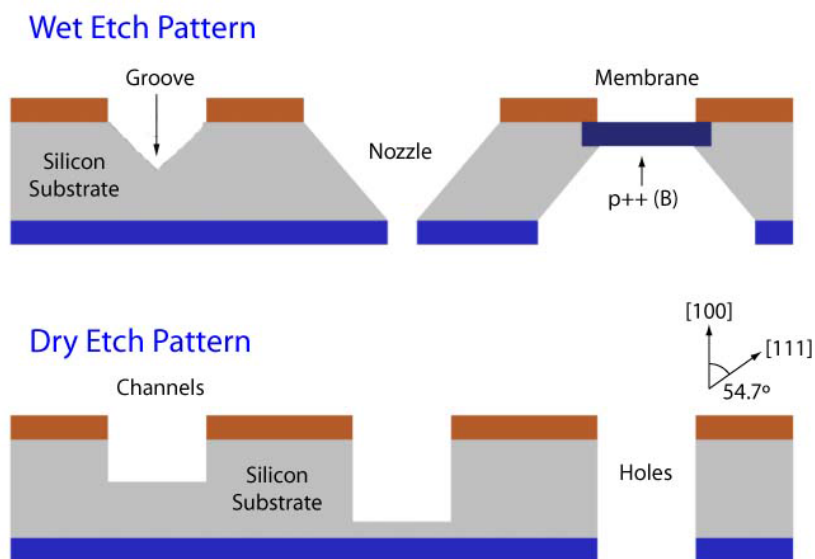

Fig.12. Wet and Dry etch techniques

Anisotropic vs. Isotropic Profiles:

Bulk micromachining uses etch processes that result in both isotropic and anisotropic etch profiles. The result (isotropic or anisotropic) depends on the etchant used and the selectivity of that etchant to the material being etched. Anisotropic etches prefer one direction over another and may be dependent upon the crystalline structure (crystal orientation) of the substrate. The etch process etches certain planes more rapidly than others (i.e., the (100) plane faster than the (111) plane). This etch rate selectivity where the selectivity varies with crystal plane orientation, provides the ability to use anisotropic etching techniques to produce specific shapes such as pyramidal cavities and v-shaped trenches.

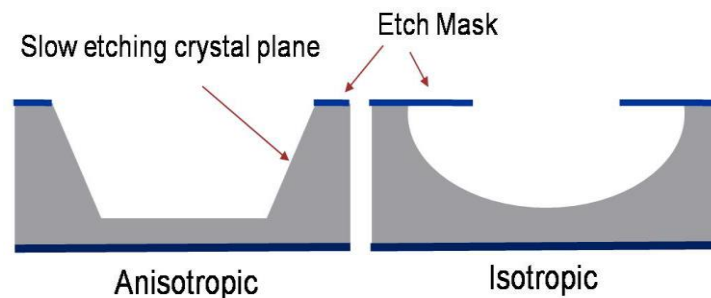

Fig.13. Anisotropic and Isotropic etch

Isotropic etch does not prefer a given direction over another. This is an etch equal in all directions as illustrated in the graphic. The typical cross sectional profile is that of a champagne glass or concave shape. It is not dependent upon crystal orientation, but rather upon the ability of the etchant to react with the material to be etched creating a volatile by-product that detaches from the wafer. Isotropic etching is characterized by its distinct profile and its undercutting of the thin film used as the etch mask. Isotropic profiles can be achieved using both wet and dry etch processes. A wet isotropic etch is used to removed the sacrificial layer from underneath a structural layer. A dry isotropic etch is used to create some of the structures and shapes needed for MEMS. The graphic below illustrates the isotropic profile versus the anisotropic profile. Anisotropic profiles can also be the result of a dry plasma reactive ion etches. The side-walls can be vertical or at an angle to the wafer plane.

Wet Etch Anisotropic Etchants

In bulk micromachining wet etching can result in either isotropic or anisotropic structures depending upon the etchant and the material being etched. The following etchants yield anisotropic profiles when etching crystalline material such as silicon:

- ❖ Potassium Hydroxide (KOH)
- ❖ Ethylene Diamine Pyrocatechol (EDP)
- ❖ Tetramethyl Ammonium Hydroxide (TMAH)
- ❖ Sodium Hydroxide (NaOH)
- ❖ $N_2H_4 \cdot H_2O$ (Hydrazine)

Costs, etch rates (i.e., how fast something etches), resulting surface roughness, selectivity between the mask material and material to be etched, relative etch ratios between the different crystal planes, safety issues, and process compatibility are some of the variables used when selecting one etchant over another.

Dry Etch:

Dry etch bulk processes use reactive vapor etchants usually in a plasma environment, or through bombarding the exposed substrate by sputtering with high energy particles. Dry etch is generally well controlled and capable of higher resolutions than wet etch. Dry etch can produce both isotropic and anisotropic profiles with critical dimensions much less than 1 μm .

Compared to wet etch tools, tools used for dry etching are more expensive and usually have a larger footprint, taking up more space in the manufacturing area. Dry etch does not leave large quantities of hazardous liquids needing to be properly disposed of; however, some of the etchants and the etched by-product (exhaust gasses) can be quite hazardous, requiring filters and neutralization systems.

Four dry etch processes used in bulk micromachining include the following

- ❖ Deep Reactive ion etch (DRIE)
- ❖ Isotropic Plasma Etching
- ❖ Sputter Etching (ion milling)
- ❖ Vapor Phase Etching

Surface Silicon Micromachining:

In addition to making cavities, microstructures can be built up step-by-step on a silicon surface. Surface micromachining originates from microelectronics and is therefore oriented towards processes and materials used for chip manufacture. Freely standing planar structures can be made such as cantilevers or membranes which hover just above the substrate surface, Fig.14.

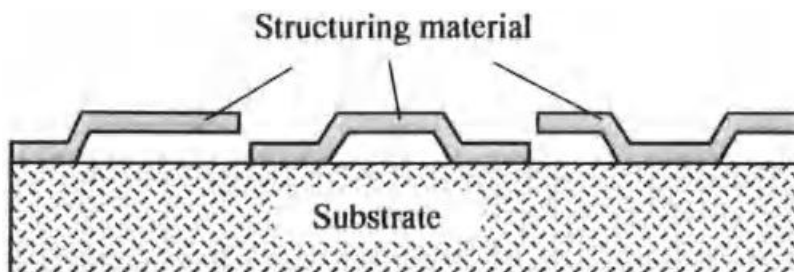

Fig. 14. Typical surface micromachining structures

The thin layer techniques and selective etching discussed before are the fundamental methods used. Metals and polycrystalline silicon are the base materials. A special feature of

surface micromachining is that the microstructure can be made with a thickness in the nm range. This is because the structure material is deposited as very thin layers. One disadvantage, however, is the possibility of mechanical stresses occurring inside the thin layer, which limits the lateral structuring dimensions. A schematic representation of the process steps for making a free-standing cantilever is shown in Fig.15. This picture helps us to give a brief overview of the possibilities of surface micromachining.

The actual structuring process starts with the deposition of a silicon dioxide layer onto the substrate, e.g. by thermal oxidation. The thickness of this layer determines the distance of the microstructure to the substrate surface. This so-called sacrificial layer is formed by a lithographic method (1) and the selective removal of the surface material (2). Afterwards, a polysilicon structure layer is deposited (3) and structured by a second lithographic etching process (4) and (5). When this process is complete, the sacrificial material is etched away and the desired microstructure remains (6). In order to obtain a more complex, three-dimensional microstructure, the sacrificial layers and structure layers can be successively applied and formed using the appropriate lithographic and etching techniques, respectively.

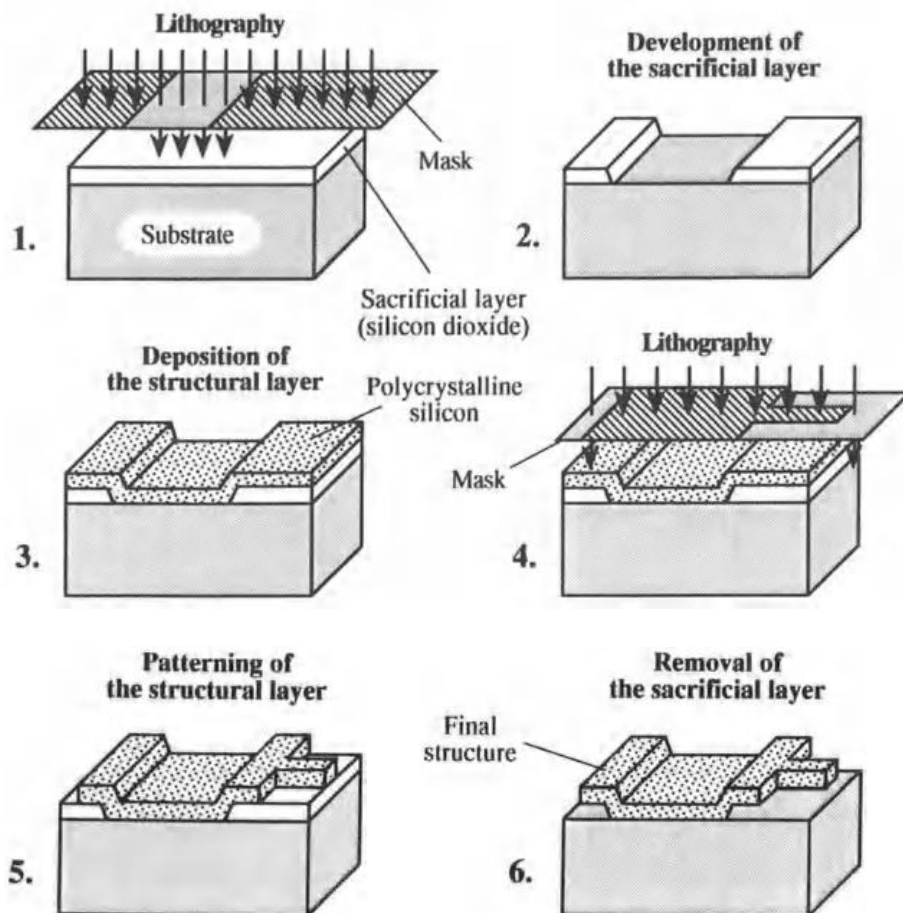

Fig.15. Processing steps of surface micromachining.

The processing steps depicted in Fig.15 shows why surface micromachining is often referred to as the sacrificial layer technique. As mentioned before, this technique can be used to make complex, three-dimensional microstructures with a height of about 20 μm from many thin layers. The structuring may start with an already processed component as a substrate, but a passivating layer such as silicon nitride must be applied to its surface first to protect this micro machined component.

LIGA Process:

LIGA means Lithographie Galvanoformung Abformung

The LIGA process consists of the following basic steps:

- ❖ Expose
- ❖ Develop
- ❖ Electroform (Electroplate)
- ❖ Strip
- ❖ Replicate or Release

The steps are

Expose:

Once the PMMA is applied to the substrate or base, synchrotron radiation patterns the PMMA through gold on beryllium mask. Like photo resist, the radiation modifies the PMMA so that the exposed material can be removed with a suitable or selective developer solution.

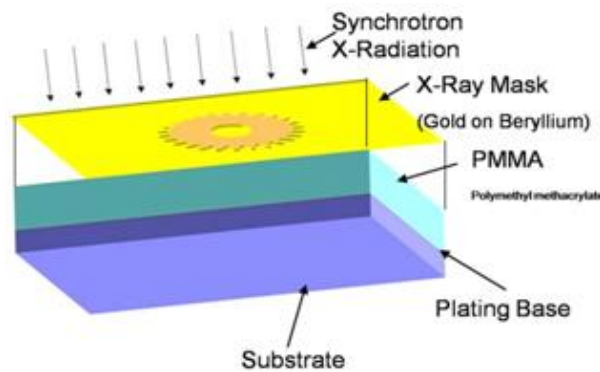

Fig.16. Micro gear using LIGA process

The fig.16 shows the radiation, the mask and the PMMA layer. The mask has the pattern of a micro-gear.

Develop:

With the use of a developer solution, the exposed PMMA is removed leaving a mold with high aspect ratio cavities, holes, or trenches.

Electroform

The cavities created in the develop step are filled with a metal (e.g., nickel, copper, gold, or various alloys) through electroforming processes.

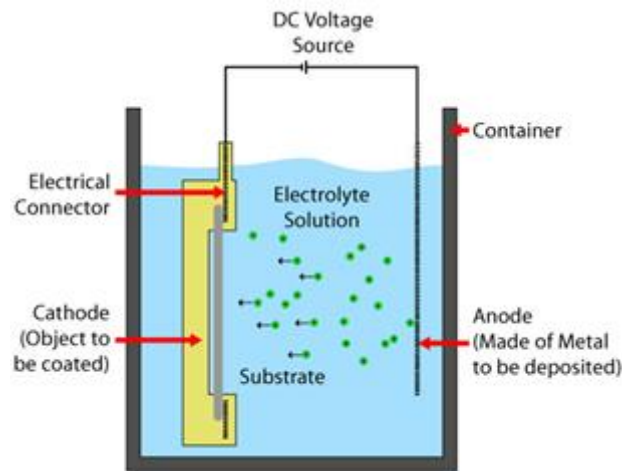

Fig.17. Electroplating

Electroforming is “the fabrication of simple and complicated components by means of electroplating”. Electroplating is a process in which a positive and a negative electrode are submerged in an electrolyte solution. The negative electrode (i.e., cathode) is the object or holds the object or substrate to be coated. In LIGA fabrication the cathode (also referred to as the mandrel) is the 3-D PMMA structures that is formed by the expose and develop processes.

During electroplating metallic positive ions (cations) released from the anode are attracted to the negatively charged cathode. When the cations reach the substrate they are neutralized by the electrons of the cathode, reducing them to metallic form. This process continues until the substrate is coated with the desired thickness.

Electroforming differs from electroplating in that it yields a much thicker layer of metal on the substrate or mandrel than the electroplating processes. In electroforming a metal object is produced (or reproduced) by coating the mandrel with the desired thickness of metal. At the end of the process, the mandrel may be removed, resulting in a self-supporting object. In electroplating the substrate is coated with a thin layer of metal which adheres to the substrate becoming a permanent part of the object (e.g., chrome faucet, jewellery, hardware).

The following graphic illustrates how the mandrel takes shape after the develop step (2) of LIGA fabrication. In the electroforming process, metal is deposited within the cavity using the process of electroplating. However, the electroplating process continues (in this case) until the cavity is completely filled.

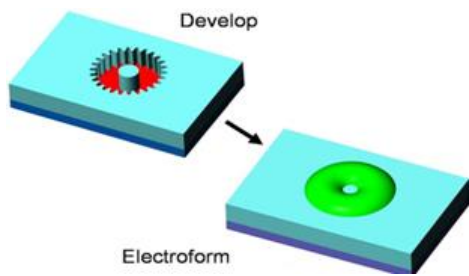

Fig.18. Develop, Electroform process

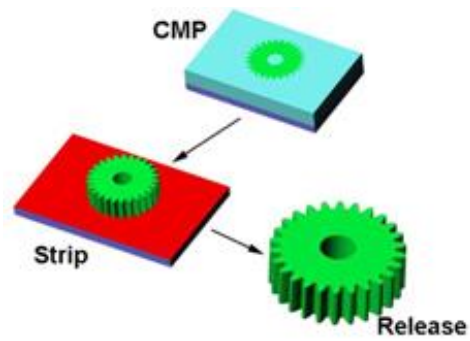

Fig.19. Strip, Release process in LIGA

Once the surface has been planarized, the PMMA removed and the metal form released, a self-supporting object remains, in this case – a metal micro gear.

Strip:

After electroforming a CMP may be performed to flatten the surface. Once the surface has been polished (planarized), the PMMA is removed or stripped. Depending on the component, the remaining structure could be used to make molds or the end product. The graphic shows these three steps (CMP, strip, release) for a micro gear.

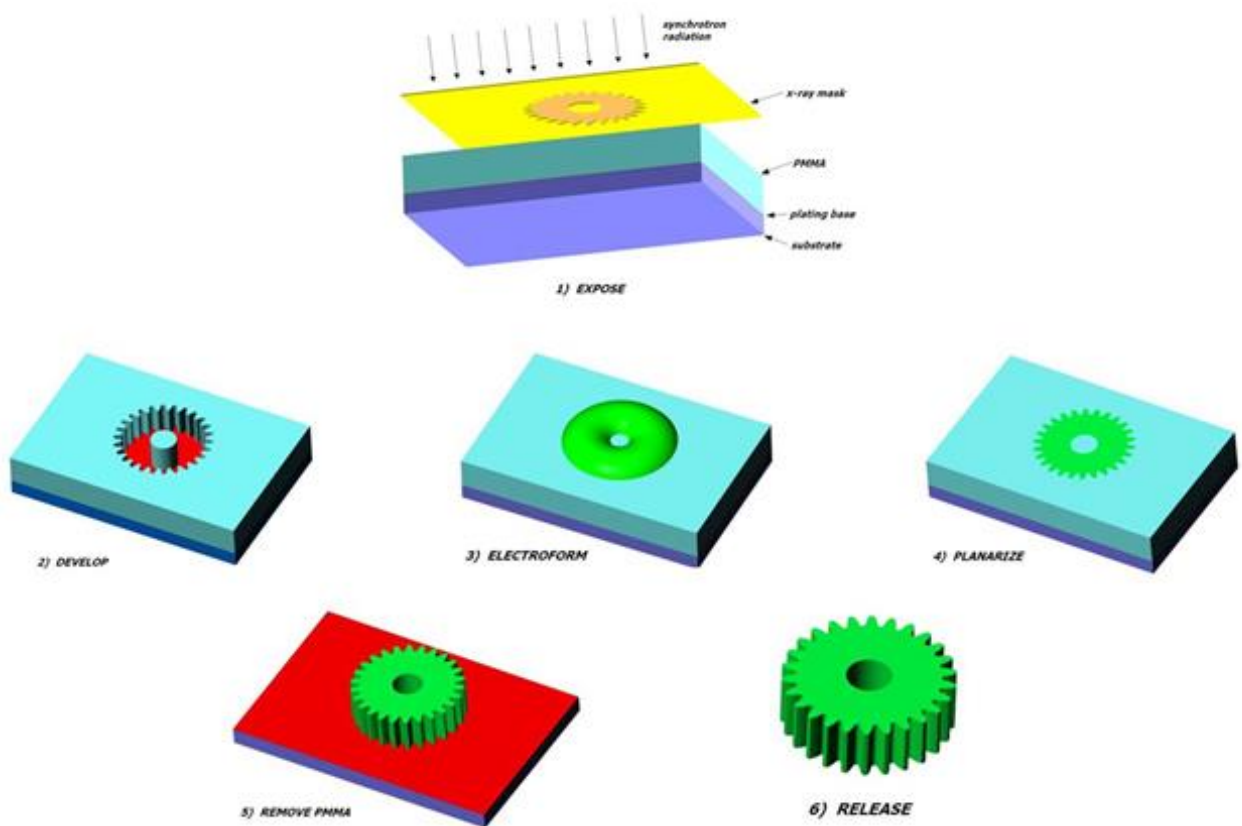

Fig.20. Full LIGA process

The LIGA process enables the creation of micro-sized high aspect ratio components that are

- ❖ free-standing,
- ❖ attached to the substrate, or
- ❖ metal inserts for injection molding.

LIGA's ability to incorporate multi-layer wafer-scale processing extends the additive approach to accommodate interfaces and packaging. LIGA components require extensive, unique metrology to ensure quality products.

MULTIPLE CHOICE QUESTIONS

1. What is PVD?
 - a) Physical vapour deposition
 - b) Primary vapour deposition
 - c) Photo vapour deposition
 - d) All the above

Answer a

2. What is CVD?
 - a) Common vapour deposition
 - b) Chemical vapour deposition
 - c) Central vapour deposition
 - d) All the above

Answer b

3. What is LIGA process
 - a) Lithographie Galvanoformung Abformung
 - b) Electroplating Lithography
 - c) Both a and b are correct
 - d) None of the above

Answer a

4. Which materials are made from chemical raw materials called monomers
 - a) silicon
 - b) Glass
 - c) Plastics
 - d) All the above

Answer c

5. Photo resists are exposed to which rays for transferring patterns?
 - a) Cosmic rays
 - b) UV rays
 - c) IR rays

d) None of the above

Answer b

6. A deposition technique based on formation of vapour of a material either heated until evaporation or sputtered by ions is called
- a) PVD
 - b) CVD
 - c) PECVD
 - d) None

Answer a

7. Micro Fluidics system is used for
- a) Drug screening
 - b) Breast Cancer diagnosis
 - c) Bacterial infection test
 - d) All the above

Answer d

8. Crucible and boats are the holders used for which type of vapour deposition method?
- a) PVD
 - b) CVD
 - c) PECVD
 - d) None

Answer a

9. The process of dipping substrate into chemical solution that selectively removes material is called
- a) Wet etching
 - b) Dry etching
 - c) Gas etching
 - d) None

Answer a

10. Isotropic and Anisotropic are the types of -----
- a) Dry etching
 - b) Machining
 - c) Wet etching
 - d) All the above

Answer c

11. Piezo electric sensors can be fabricated using micro fabrication techniques. The property of piezoelectric material is

- a) To accumulate electric charge w.r.t the mechanical stress applied
- b) To accumulate electric charge in response to the potential gradient
- c) To accumulate electric charge when placed in magnetic field
- d) To generate mechanical stress in electric field

Answers: a

12. Photolithography is an important step in micro fabrication, what do you understand by “Lithography”?

- a) Transferring pattern on a mask.
- b) Transferring pattern on to a substrate.
- c) Slicing wafer by LASER or by UV.
- d) Deposition of any material on a substrate

Answers: b

13. ----- is the most abundant and easily available sensing material.

- a) Gold
- b) Silicon
- c) Ceramics
- d) All the above

Answer b

14. What is nano technology?

- a) Technology conducted at micro scale
- b) Technology conducted at pico scale
- c) Technology conducted at nanoscale
- d) None

Answer c

15. A micromachining defines structures by selectively etching inside a substrate is called

- a) Bulk micromachining
- b) Surface micromachining
- c) LIGA process
- d) All the above

Answer a

ASSIGNMENT

1. Explain in detail about the following materials used in sensors.
 - a) Silicon b) Metals c) Glasses
2. Explain in detail about the working principles of Vacuum deposition with diagram.

CONCLUSIONS

The basic principle of working of resistive, capacitive and inductive sensors and transducers were discussed and its applications were elaborated in this material. In the third unit Hydraulic, pneumatic and electric actuators were thoroughly mentioned. Miniaturized sensors and actuators working principle and applications were seen.

Surface properties of the material can affect the efficiency and behaviour of the material when in service. Modifying and tuning these surface properties to meet the specific demand for better performance is feasible and has been vastly employed in a different aspect of life. This can be achieved by coating the surface via deposition of the thin film. The fifth unit of this study material provides a review of the existing physical vapour deposition techniques used for surface modification and coating. The area of applications of surface coating was briefly highlighted in this note. The sputtering and LIGA technique is discussed and the comparison between evaporation techniques was explained.

Sensors and actuators are increasingly being used for many technical applications. A sensor is a vital organ of an artificial system, forming the interface between the controller and the environment. Sensors can smell, taste, see and feel by measuring mechanical, biochemical, thermal, magnetic and radiation parameters. Actuators are mainly used in medical and industrial purpose. Using MST technology, sensors and actuators are manufactured in miniaturized size well suited for various applications. Micro sensors have high reliability, low weight and volume, and low mass-production cost makes it suitable for smart applications in enormous fields. The rapid development of micro sensors and micro actuators will play a major role in the future world.

VIDEO LINKS

1. <https://www.slideshare.net/saaz1425/dc-motor-23906628> DC Motor principles
2. <https://www.electricaleasy.com/2014/01/basic-working-of-dc-motor.html> Motor working animation
3. <https://www.youtube.com/watch?v=hmp5CSlendo> Variable reluctance stepper motor
4. <https://www.youtube.com/watch?v=uxXg1RxEIY8> Thermal evaporation
5. <https://www.youtube.com/watch?v=T2FXGL-d0sQ> - E beam Evaporation
6. <https://www.youtube.com/watch?v=O63R9qRglnY> sputtering

REFERENCE BOOKS

1. Patranabis.D, Sensors and Transducers, Wheeler publisher, 1994.
2. Sergej Fatikow and Ulrich Rembold, “Microsystem Technology and Macrobotics” First edition, Springer –Verlag NEwYork, Inc, 1997.
3. Jacob Fraden, “Hand Book of Modern Sensors: Physics, Designs and Application” Fourth edition, Springer, 2010.
4. Robert H Bishop, “The Mechatronics Hand Book”, CRC Press, 2002.
5. Thomas. G. Bekwith and Lewis Buck.N, “Mechanical Measurements”, Oxford and IBH publishing Co. Pvt. Ltd.,
6. Massood Tabib and Azar, “Microactuators Electrical, Magnetic, thermal, optical, mechanical, chemical and smart structures”, First edition, Kluwer academic publishers, Springer,1997.
7. Manfred Kohl, Shape Memory Actuators, first edition, Springer.
8. "Surface Engineering for Corrosion and Wear Resistance Application," Nptel Course material.

QUESTION BANK

UNIT-I - SENSORS

PART-A

1. Differentiate sensors and transducers.
2. Distinguish between static and dynamic characteristics.
3. Give the factors responsible in selection of a sensor or actuator.
4. What is meant by repeatability?
5. Define Accuracy and Precision.
6. What is mean by smart transmitter?
7. Explain transmitter gain.
8. List the types of signals.
9. What is backlash?
10. Define gauge factor
11. List the applications of thermistors
12. Give the advantages and disadvantages of LVDT
13. What is RTD?
14. What is photo resistive sensor?
15. Explain the principle of resistance hygrometer

UNIT-II - INDUCTIVE & CAPACITIVE TRANSDUCER

PART-A

1. List any two inductive sensors.
2. Explain the principle of inductive transducers

3. Explain the principle of capacitive transducers
4. Give the application of synchros.
5. What are the types of proximity sensors?
6. Mention any four capacitive sensors.
7. Mention the applications of capacitive pressure sensor?
8. State the need of sensors in robotics.
9. Explain the principle of capacitive microphone.
10. Draw the diagram of LVDT

UNIT-III - ACTUATORS

PART-A

1. Define actuator.
2. Classify the types of actuators.
3. Define valve co-efficient.
4. Define stepper motor.
5. Explain the principle of Induction motor.
6. Mention the applications of Synchronous motor.
7. How a transistor can be operated as a solid state switch.

UNIT-IV - MICRO SENSORS AND MICRO ACTUATORS

PART-A

1. Define Microrobots.
2. What is inverse piezo effect?
3. What is micro sensor? Give an example.
4. Explain the principle of a piezo resistive pressure sensor
5. Why we need micro flow sensor?
6. Mention the application of bio sensor.
7. Define Shape memory effect.

UNIT-V - SENSOR MATERIALS AND PROCESSING TECHNIQUES

PART-A

1. What is the Nano particle? List any two uses of it.
2. Define sputtering.
3. List out the sensor materials.
4. What is LIGA process?
5. Give the application of vacuum deposition.
6. Define electroplating.
7. Explain the principle of photolithography.

PART B

UNIT-I - SENSORS

1. Discuss the following static characteristics: Accuracy, Precision, Resolution, Sensitivity, backlash and Response time.
2. Write short notes on (i) Bellows (ii) Diaphragm
3. What are primary sensing elements? Explain the construction and working of Bourdon tube with neat diagrams.
4. Explain in detail about the following
 - a) Pneumatic Signal (6)
 - b) Hydraulic Signal (5)
 - c) Electronic Signal (5)
5. Elaborate the working of Strain gauge with neat diagram.
6. What is RTD? What are its types? Explain its working with neat diagram.
7. Discuss the working of Hot wire Anemometer
8. Explain the working of Hygrometer.
9. What are Thermistors? Explain their different forms of construction. Draw their resistivity versus temperature characteristics curve. Describe any one application with neat circuit.

UNIT-II - INDUCTIVE & CAPACITIVE TRANSDUCER

PART-B

1. Explain the construction, principle of operation, circuit and applications of Variable reluctance transducer with neat diagrams.
2. Describe the construction of LVDT and explain its principle of operation with the aid of diagram, list the advantages, disadvantages and applications of LVDT.
3. Elaborate the working principle of proximity sensors with neat diagram in detail. List its applications.
4. Write short notes on
 - a) Microsyn (8)
 - b) Capacitor microphone (8)
5. Discuss the working principle, operation and applications of Capacitor pressure sensor.

UNIT-III - ACTUATORS

PART-B

1. Explain the working principle and operation of piezoelectric actuators.

2. Explain the following:
 - a) Single and double acting cylinders (8)
 - b) Hydraulic Systems (8)
3. Explain the working principle and characteristics of DC Motor.
4. Discuss the Construction and characteristics of control valves used in Hydraulic actuators.
5. Explain the working principle and characteristics of three phase Induction Motor.
6. What is stepper motor? Explain the working of full stepping, half stepping and micro stepping of variable reluctance stepper motor with relevant diagrams.

UNIT-IV – MICRO SENSORS AND MICRO ACTUATORS

PART-B

1. Draw the schematic of micro pressure sensor and explain briefly.
2. Explain the working of Hydraulic piston micro actuator with relevant diagrams
3. Explain the working of Electrostatic micro pump with diagrams
4. Draw the schematic design of a micro biosensor and explain. Also draw the sensor response curve and explain.
5. What is a shape memory alloy? Discuss one way and two way shape memory effect with diagrams.
6. Describe the Motion Principle of Electrostatic Micro actuators. Explain the Working principle of an electrostatic micro valve with neat diagram.
7. Discuss

UNIT V-SENSOR MATERIALS AND PROCESSING TECHNIQUES

PART-B

1. Elaborate the various steps involved in photolithography.
2. Explain in detail about the working principles of Vacuum deposition with diagram.
3. Describe sputtering technique for deposition of thin and thick films on sensing surface.
4. Explain in detail about the following materials used in sensors.
 - b) Silicon
 - b) Metals
 - c) Glasses
5. Explain in detail about the LIGA process.
6. Describe about the Chemical vapour deposition with appropriate diagrams.